

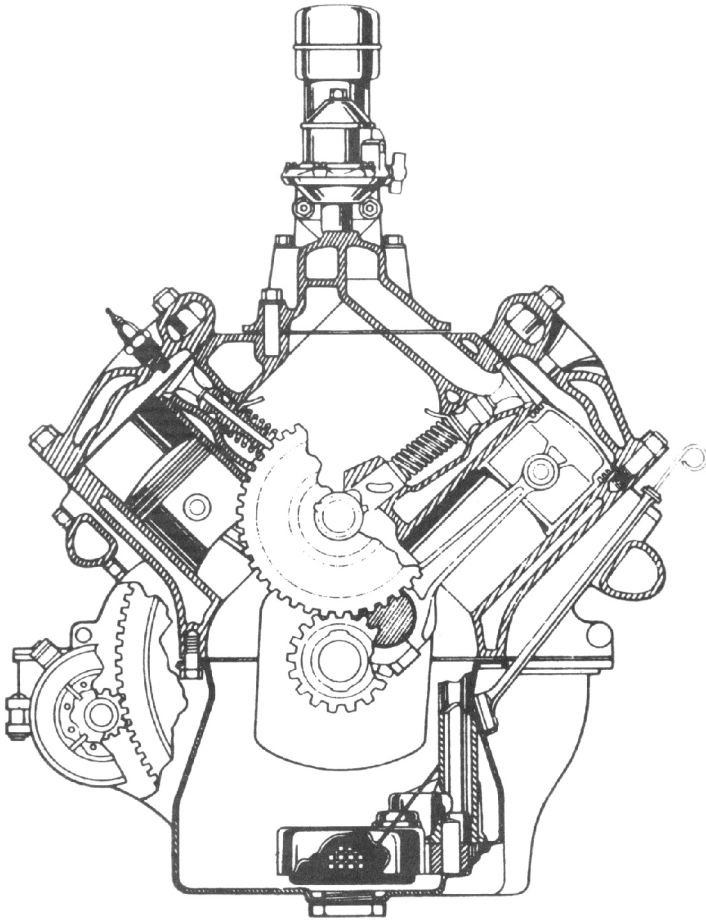

Drive Lines

Chapter #40
Our 48th Year
Visit Our Website
"valleyV8s.org"

Feb 2019



The Valley V8's
9700 Farralone, Chatsworth, Ca. 91311

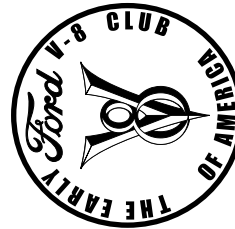

The Valley V's

2019

President	Ernie Baily	805-428-0558
Past Presidents	Vaskin Hagopian	323-661-2044
Vice President	Jim Ellerbrock	818-437-0412
Secretary	Rex Jaramillo	213-706-3854
Treasurer	Joan Sapper	818-249-5686
Tours	Kenney Sapper	818-249-5686
	RichCarter	708-567-2393
Programs	Larry Caplan	818-363-2849
	Joe DiFatta	818-700-1939
Membership	Sandrine Cutright	310-804-7790
	Oliver Calibet	818-310-8571
	Joan Sapper	818-249-5686
Drive Lines	Robert Glucksman	818-618-1395
Prize Raffle	Steve Boskovich	818-341-6876
50/50	Ken Sapper	818-380-5686
Ladies / Birthdays / Sunshine	Bobby Searl	818-353-6767
Name Badge	Karen Lehman	818-885-6938
Car of the Month	Jerry Jensen	805-491-3355
Web Master	Scott Dudrick	818-687-9836
Tech. Advisor	John Wolf	818-789-6201

Meeting: 1st Tuesday of the Month, 7:00p
 No host Dinner, Starting at 6:00p
 Rosie's BBQ & Grill, 8930 Corbin Ave.
 Northridge, Ca. 91324

Visit our Web Site: valleyv8s.org

Facebook: **Valleyv8s**

(<https://www.facebook.com/groups/579123315803014>)

Drive Lines is Published by

The San Fernando V8's Regional Group 40
 of the Early Ford V8 Club of America
 9700 Farralone, Chatsworth, Ca. 91311

The Valley V's

Past Presidents

Jim Rowe	1971
Doug Peterson	1972
Don Durkee	1973-1974
Ed Warnock	1975
John Busk	1976
Chip Werstein	1977
Stan Misraje	1978
Bill Culp	1979
Al Spencer	1980
Larry Caplan	1981
Bob Rose	1982
Don Durkee	1983
Paul Kirk	1984
Kent Lowry	1985
Dave Sanborn	1986
John Kemmerer	1987
Dudley Ochsner	1988
Jerry Jensen	1989-1990
Joe DiFatta	1991
Chuck Shubb	1992-1993
George Richards	1994
Jerry Littner	1995
Dick Smith	1996
Chuck Mair	1997
Dennis Keene	1998
Rose Golt	1999
Don Stout	2000
Steve Boskovich	2001-2002
Joe DiFatta	2003
Wendi Potter	2004
Ken Sapper	2005-2006
Steven Batesole	2007
Harry Baker	2008-2009
Dave Bergman	2010
Randy Watson	2011-2012
Steve Boskovich	2013-2014
Stan Miller	2015
Don Durkee	2015
Vasken Hagopian	2016-2018
Ernie Baily	2019-????

"Your Ad Here"
For only \$5.00 a month,
YOU
 can have your
 business card ad
 right here

For more details,
Please call or Email Rob at
818-882-2002, / madmodelr@aol.com
Please put "Drivelines" in the subject
Please make all payments to
"Valley V8 Club"



HELLO FELLOW MEMBERS

We would like to know more about You,
 Your Car...

So, What I would like from our members is
 a picture of you with your car, with a small
 story. (1 Paragraph)

That way, We get to learn more about our
 members, & we can put a face to a name &
 car

Please make all submissions to ether
 "Drivelines" at madmodelr@aol.com, or
 "Drivelines" 9700 Farralone Ave.

Chatsworth, Ca. 91311

Thank You

Rob Glucksman, DL Editor

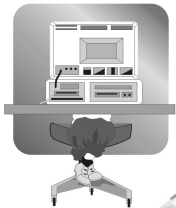

R.H.FACTOR GRAPHICS

*Computer Graphics
 Desktop Publishing*



For all your Pre-Press needs

Robert Glucksman
Chatsworth, Ca. 91311
Office: 818-882-2002
Cell: 818-618-1395
madmodelr@aol.com

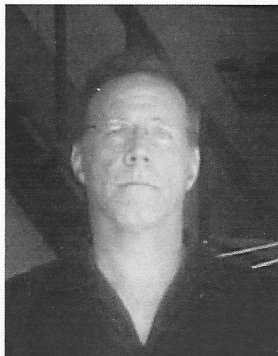
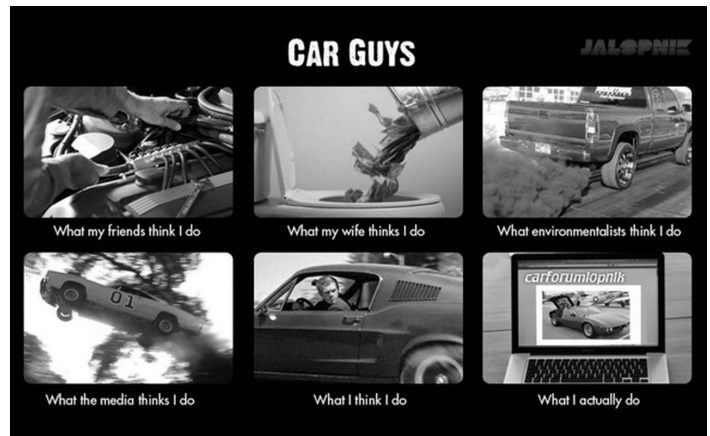

ARBONNE.
 INDEPENDENT
 CONSULTANT

Steven Lehman
 Arbonne Independent Consultant
 Consultant
 23592171

Reset, Restore, Rebalance
 Discover Ultimate Health,
 C 818.517.1268

ArbonneForever@yahoo.com
 www.stevenlehman.arbonne.com

SPEEDWAY ENGINEERING



Ken Sapper
President

ken@1speedway.com
 Office: 818.362.5865
 Cell: 818.326.1286
 Fax: 818.362.5608
 13040 Bradley Avenue
 Sylmar, CA. 91342
 www.1speedway.com

CAR OF THE MONTH

Handled by Jerry Jensen

Purchased by my father in 1975. Preparing for retirement, he needed a project. He drove a similar truck when they were new as a delivery boy for a pharmacy ("Apothecary" back then) in Minot ND. Grew up hearing him occasionally say "prettiest Ford truck ever". I'm afraid I agree! Became a two year project. Decision made to retain hydraulic brakes and postwar engine already installed. Keeping later brakes meant keeping Kelsey Hayes wire wheels. Painted Washington Blue. Columbia installed be me in '90s to make more useable for driving to meets and such. Entered into "local"(within 200 miles or so) V8 club meets for the last 20 years in Touring class.
Steve Batesole

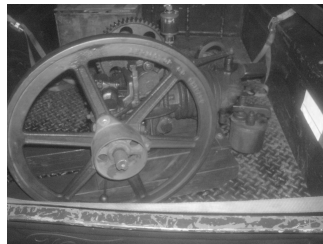

Program / Speaker

Joe DiFatta introduced Jim Diamond and our Program for the Evening. Jim grew up in Rock Island, Iowa, home of the first railroad bridge, built in 1952 across the Mississippi, to the Rock Island Arsenal and where Jim developed a fondness for Jeeps. Hence his presentation, the development of the "General Purpose" vehicle, from American Bantam to Willys and Ford. American Bantam's opportunity came when the U S Army gave it a contract to develop a new 1/4-ton four wheel drive "Utility" vehicle. Bantam's design laid the ground work for what would be forever known as the Jeep. However, due to Bantam's limited facilities and the production numbers needed, the U.S. Army gave the high-volume contracts to Willys-Overland and Ford. American Bantam found its place as a manufacturer of various types of trailers, to tag along with the Jeeps. See Blake Wilcox, if you want more on Jim's presentation.



*And now for some
"Pressing" News*

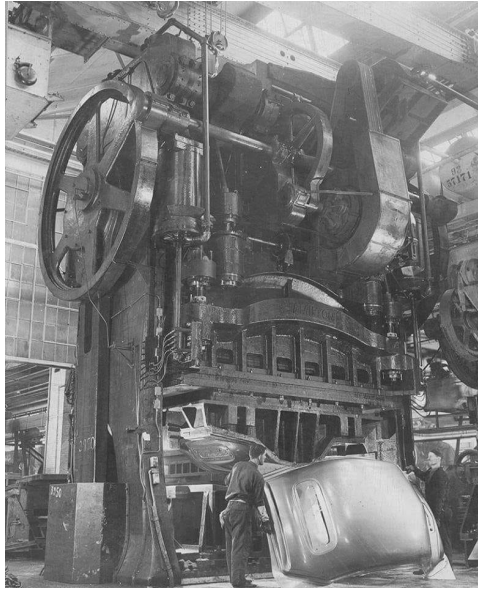

Speaker

February 5th Program

This month we have as our program speaker Mr. Cliff Mickool, who is with the Barrett - Jackson Auction Group .
Cliff has spoken to use before, but always has more to add about his travels.
I am still amazed about how & when the auctioncars go on display... that perhaps 1800 hoods are opened & closed on each car
Make it a "New Years" resalution to add our Ford Club meetings
See you on the 5th of Feb



FROM THE EDITORS DESK

Hello Fellow V8'ers

Let Me start with sending Best Wishes & Get Well to Stan Miller, & Chuck Shubb

You may notice that this months newsletter has a little bit of a new look...
Well, I'm reverting back to My days in Graphic Design, & give OUR newsletter a little more style by adding "Headers" & Story breaks.

Also, I know some of the stories are shorter that usual, that will return normal in the near future
Please, drop Me a line, Let Me know what you think...

Rob / DLE



**I refuse to join
any club that
would have
Me as a member**

Groucho Marx

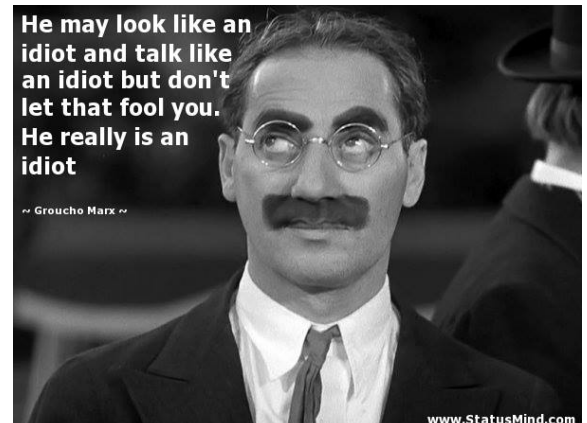

**He may look like an
idiot and talk like
an idiot but don't
let that fool you.
He really is an
idiot**

~ Groucho Marx ~

www.StatusMind.com

From The President

Well! My first meeting went along Ok! Unfortunately we had some sad news about our long time member Robert Zecher passing. For me it hit hard as I just lost my brother in law and aunt. I really enjoyed our speaker talking about the "Jeep"! It brought back some great memories working with my uncle, building one from a crate. I'm hoping to put together a board meeting before for our meeting in order to have some events as soon as possible. If you have any suggestions please contact my self or any of board members. See you all at the meeting.

Ernie Baily

CHAPTER 40 -- SAN FERNANDO VALLEY V-8'S CLUB

Monthly Meeting Minutes for Tuesday Jan. 8, 2019

Secretary Fill- in ...

At precisely 1900 hours, on January 8, 2019, President Ernie Baily bangs the gavel, at Rosie's BBQ & Grillery and the Valley V-8's ride into 2019, for another year of activities. Pres Ernie asks for an introduction of guests. Other than our guest speaker, who will be introduced later, there are none, this evening. Ernie next calls for the Pledge of Allegiance, led by John Wolf, in John Fredrick's absence.

On to announcements;

Pres got a call from past National President, Ed Warnock, asking Ernie to let us know that member Robert Zecher passed away. Memorial Service is scheduled for February 23rd^h, at 1500 hours, in Forrest Lawn, 1712 Glendale Ave, Glendale.

Joe DiFatta announced that Chuck Shubb fell and is in the hospital. ... He should be out by the time you read this. So, how-about giving Judy and Chuck a call, to see how he's doing and possibly pay a visit.

(As of 20 Jan, Chuck IS home)

Ken Sapper is in the planning stages of a tour to Justice Brother's Racing Museum, in Duarte. The Museum is closed on weekends, so Ken is looking at a Friday in March. Stay Tuned.

Vasken Hapogian, next took the podium to present Scott Doudrick with a certificate, for his service as Web Master in 2017 & 2018.

Officer Reports:

Treasurer & Membership: Joan Sapper says we finished the year in the black and are starting the new year with a positive checking account. Filling in for Oliver Calibet, Joanie says give her your dues. She will see that you are checked off Oliver's list.

Editor, Robert Glucksman asked all members to send him a paragraph about yourself and your car(s) A mug shot would also be appreciated, since he has yet to put many names with faces.

Secretary, hurt his back and it looks like he'll be spending some time in the prone position. Get well Rex! With no other New, or Old Business President Ernie called for the Break.

Following the break: Steve Batesole's '36 pickup was selected as car of the month. More on Steve's pickup will be available, once he sends his bios to the Editor.

Bobbie Searl presented Ladies' Prizes of Anthurium plants to Karen Lehman and Val Elenbrock, holding winning tickets. Name Badge drawing won by Robert Glucksman and 50/50 drawing, with a prize of \$58, went to Phil Goeschl.

Program for the Evening

Joe DiFatta introduced Jim Diamond and our Program for the Evening.

Following the Raffle, meeting adjourned at 2035 hours.

... Respectfully submitted

John Kemmerer

The Valley V-8's 2019 Membership Application & Renewal Form

In order to continue to receive the Drivelines and remain in the roster...

Or to join our club...

Please renew your membership by February 15, 2019

Name: _____ Birthday Month: _____ Day: _____

Spouse: _____ Birthday Month: _____ Day: _____

Address: _____ City: _____ State & Zip _____

Phones - Home _____ Cell _____ Work _____

Email: _____

Occupation: _____

Year Joined: _____

Early Ford V-8 Vehicle(s) Owned - if same as prior year write "NO CHANGE"

<u>Year</u>	<u>Make</u>	<u>Model</u>	<u>Body Style</u>
_____	_____	_____	_____
_____	_____	_____	_____
_____	_____	_____	_____
_____	_____	_____	_____
_____	_____	_____	_____
_____	_____	_____	_____

For Regional Membership: Send a \$35.00 check - payable to: Valley V-8's

Mail check to: Valley V8's C/O Oliver Calibet 6732 Gaviota Ave., Lake Balboa, CA 91406

If you have any questions please call 818-310-8571 Email: sixty4500@gmail.com

NOTE: For us to meet insurance requirements, a Regional Group Member **MUST** also be a member of the Early Ford V-8 Club of America. Minimum membership is \$35.00 per year. Please contact me for mailing information or <http://www.earlyfordv8.org>