

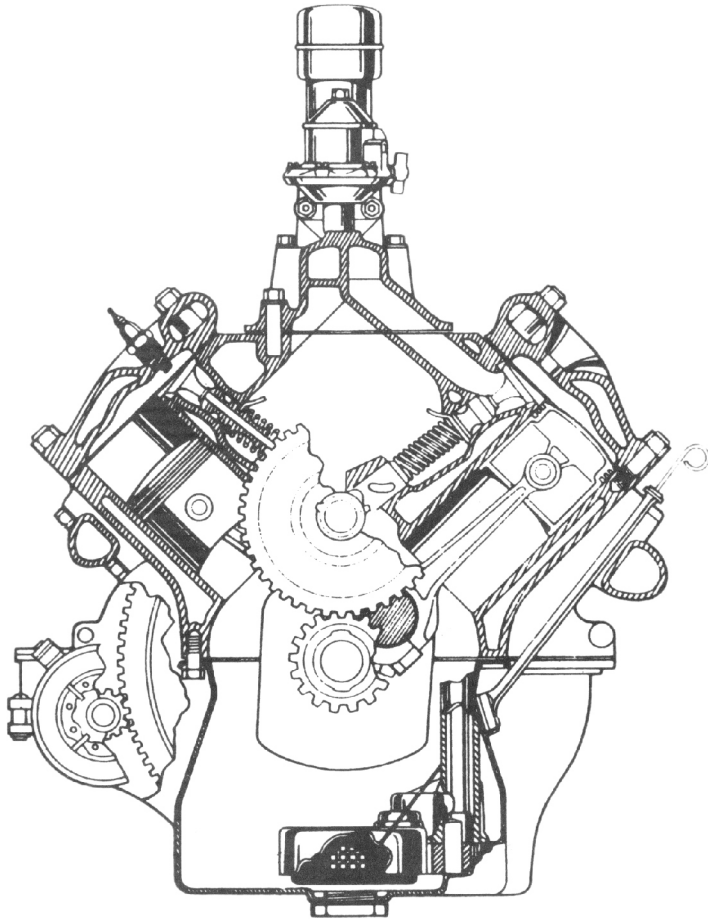

# Drive Lines

Chapter #40  
Our 48th Year  
Visit Our Website  
"valleyV8s.org"

Mar 2019



The Valley V8's  
9700 Farralone, Chatsworth, Ca. 91311

# The Valley V's

## 2019

President	Ernie Baily	805-428-0558
Past Presidents	Vaskin Hagopian	323-661-2044
Vice President	Jim Ellerbrock	818-437-0412
Secretary	Rex Jaramillo	213-706-3854
Treasurer	Joan Sapper	818-249-5686
Tours	Kenney Sapper	818-249-5686
	RichCarter	708-567-2393
Programs	Larry Caplan	818-363-2849
	Joe DiFatta	818-700-1939
Membership	Sandrine Cutright	310-804-7790
	Oliver Calibet	818-310-8571
	Joan Sapper	818-249-5686
Drive Lines	Robert Glucksman	818-618-1395
Prize Raffle	Steve Boskovich	818-341-6876
50/50	Ken Sapper	818-380-5686
Ladies / Birthdays / Sunshine	Bobby Searl	818-353-6767
Name Badge	Karen Lehman	818-885-6938
Car of the Month	Jerry Jensen	805-491-3355
Web Master	Scott Dudrick	818-687-9836
Tech. Advisor	John Wolf	818-789-6201

Meeting: 1st Tuesday of the Month, 7:00p  
 No host Dinner, Starting at 6:00p  
 Rosie's BBQ & Grill, 8930 Corbin Ave.  
 Northridge, Ca. 91324

Visit our Web Site: [valleyv8s.org](http://valleyv8s.org)

Facebook: **Valleyv8s**

(<https://www.facebook.com/groups/579123315803014>)

Drive Lines is Published by

The San Fernando V8's Regional Group 40  
 of the Early Ford V8 Club of America  
 9700 Farralone, Chatsworth, Ca. 91311

# The Valley V's

## Past Presidents

Jim Rowe	1971
Doug Peterson	1972
Don Durkee	1973-1974
Ed Warnock	1975
John Busk	1976
Chip Werstein	1977
Stan Misraje	1978
Bill Culp	1979
Al Spencer	1980
Larry Caplan	1981
Bob Rose	1982
Don Durkee	1983
Paul Kirk	1984
Kent Lowry	1985
Dave Sanborn	1986
John Kemmerer	1987
Dudley Ochsner	1988
Jerry Jensen	1989-1990
Joe DiFatta	1991
Chuck Shubb	1992-1993
George Richards	1994
Jerry Littner	1995
Dick Smith	1996
Chuck Mair	1997
Dennis Keene	1998
Rose Golt	1999
Don Stout	2000
Steve Boskovich	2001-2002
Joe DiFatta	2003
Wendi Potter	2004
Ken Sapper	2005-2006
Steven Batesole	2007
Harry Baker	2008-2009
Dave Bergman	2010
Randy Watson	2011-2012
Steve Boskovich	2013-2014
Stan Miller	2015
Don Durkee	2015
Vasken Hagopian	2016-2018
Ernie Baily	2019-????

**"Your Ad Here"**  
*For only \$5.00 a month,*  
**YOU**

can have your  
business card ad  
right here

**For more details,**  
Please call or Email Rob at  
**818-882-2002, / madmodelr@aol.com**  
Please put "Drivelines" in the subject  
Please make all payments to  
**"Valley V8 Club"**



## HELLO FELLOW MEMBERS

We would like to know more about You,  
Your Car...

So, What I would like from our members is  
a picture of you with your car, with a small  
story. (1 Paragraph)

That way, We get to learn more about our  
members, & we can put a face to a name &  
car

Please make all submissions to ether  
"Drivelines" at [madmodelr@aol.com](mailto:madmodelr@aol.com), or  
"Drivelines" 9700 Farralone Ave.

Chatsworth, Ca. 91311

*Thank You*

Rob Glucksman, DL Editor

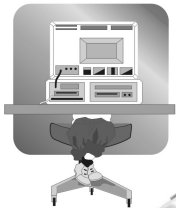

### **R.H.FACTOR GRAPHICS** *Computer Graphics Desktop Publishing*



*For all your Pre-Press needs*

**Robert Glucksman**  
Chatsworth, Ca. 91311  
Office: 818-882-2002  
Cell: 818-618-1395  
[madmodelr@aol.com](mailto:madmodelr@aol.com)

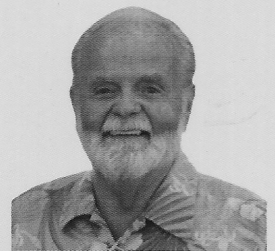
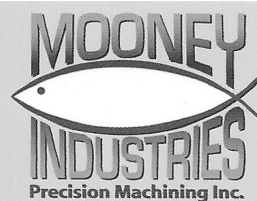

**AL MOONEY**  
C.F.O.

8744 REMMET AVE.  
CANOGA PARK, CA 91304  
(818) 998-0199  
FAX (818) 341-2073

[al@mooneyindustries.com](mailto:al@mooneyindustries.com)

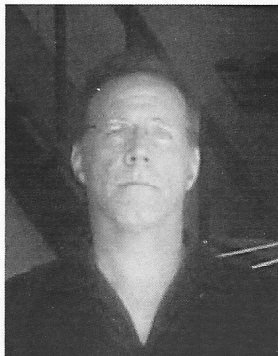

ARBONNE.  
INDEPENDENT  
CONSULTANT

**Steven Lehman**  
Arbonne Independent Consultant  
Consultant  
23592171

Reset, Restore, Rebalance  
Discover Ultimate Health,  
C 818.517.1268

[ArbonneForever@yahoo.com](mailto:ArbonneForever@yahoo.com)  
[www.stevenlehman.arbonne.com](http://www.stevenlehman.arbonne.com)

## SPEEDWAY ENGINEERING



**Ken Sapper**  
President  
[ken@1speedway.com](mailto:ken@1speedway.com)  
Office: 818.362.5865  
Cell: 818.326.1286  
Fax: 818.362.5608  
13040 Bradley Avenue  
Sylmar, CA. 91342  
[www.1speedway.com](http://www.1speedway.com)

# CAR OF THE MONTH

Handled by VP Jim Ellerbrock

Car of the Month went to Steve Boskovich and his '48 Sedan.

Steve's Beautiful 48 Ford is painted in a stock color for Rag tops, However He chose it for his coupe..

On a further note, Steve's 48, has been given to the "The Ages" by way of being immortalized as a model.

Rob / DLE

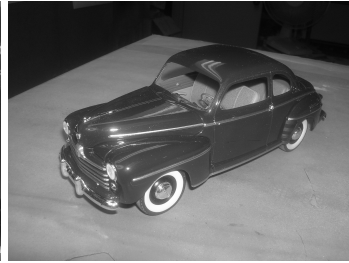

Guess Who?????

Guess Where?????

He has been with the Valley V8's for a very long time

This is His first Ride, & He's on a very famous cruising blvd. before it was famous in the San Fernando Valley

The answer will be posted on our Web & FB sites

Rob / DLE

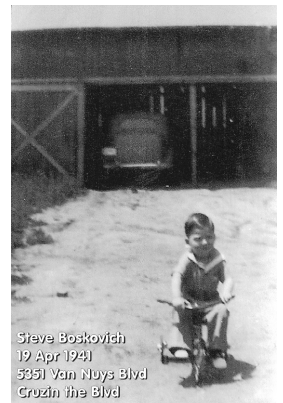

## Program / Speaker

**Program:**— Larry Caplan introduced our speaker, Cliff McCool, with the Barrett-Jackson Auction Company. The club asked Cliff many questions about his experiences with B/J and we learned a lot of new facts! As of Jan 18, 2018, Cliff got the permit he has been needing and is now ready to pour cement later this month. Cliff has been with B/J for 11 years. His job is to move the cars onto the red auction block, open the hoods, then move off. Average time car is on the block is 90 seconds to 2 minutes! Over 1800 hoods are lifted each year. Auctions are held in Scottsdale, Palm Beach, Connecticut, and Las Vegas. Coming soon Texas may be added this year. Average price on cars is \$18,000-\$30,000. Popular sale items recently are the Resto-Rods. To put a car into auction, seller puts up \$500-\$600. Buyers (bidders) must bring with them either a letter from the bank verifying funds or they bring a suitcase of cash. Bidders pay an admission price of \$550.

Cliff has no other side job to this. He has always loved cars. All cars up to auction are inspected by B/J. Four B/J experts go over the cars on a rack and check they are according to a "description" provided by sellers. Cliff still warns to buyers to beware. Check these cars "on-line" and talk to the sellers before the auction. Buyers also need to set a limit for themselves. There are 3 types of buyers: First time buyers, Collectors, and Dealers.

The highest bid in B/J history is \$2.5 million for car purchased by Rick Hendricks. Cliff describes the auctions as a lot of fun. Of the 5,000 bidders on floor, it only takes two bidders interested in same car to make a bidding war. He says it is a good way to sell and he will continue with B/J as long as he can.

We thank you Cliff for sharing with us your love of cars!  
Everyone was very interested in your presentation tonight.





## *And now for some "Pressing" News*

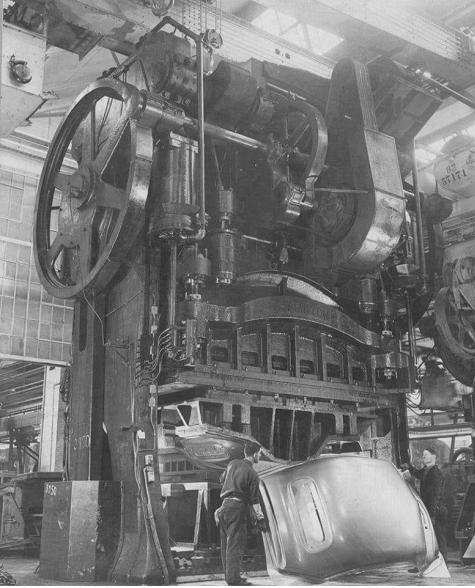

# Speaker

Jim Kelley is going to take advantage of living in those good old days. He plans to tell about the cars that passed through his life starting in 1926. Yes: that right 93 years ago, starting with the model T ( the Tin Lizzy). Liquids for you cars were bought at the Hardware store. You would know it as paint thinner today. No Paved Streets, no radios, no TV, no phone, no refrigerators, NO SOCIAL SECURITY TAKEN OUT OF YOUR PAY CHECK, homeless people had character and were called Hobos. They had to work for their free meals.

What did we do for entertainment , well to start I am one of seven children.....

JoeD

**Our Next Meeting**  
**Tues, 5 Mar 19**

## *Tours*

V8 TOUR COMING UP IN MARCH -

Join us for a fun trip to the **Justice Bros Racing Museum**. We are hoping to get a guided tour by Ed Justice himself on a Friday morning. Date is still to be confirmed. After a good look at the collection, we will travel to a local eatery for lunch.

The Justice Brothers Racing Museum in Duarte, California is a terrific place to see the evolution of motor sports. Founded in 1985, the Museum has a wide variety of vintage circle track racecars, ice racing motorcycles, street rods, restored classics, Indy cars from past and present (including two from the Sylvester Stallone movie Driven), dragsters, midgets, a stadium truck, historic engines, model cars, antique gas pumps and even a Pitts acrobatic biplane hanging from the ceiling!

Please let Ken Sapper know if you are interested in coming. Call him at 818-326-1286 and get on the sign-up list!!



# From The President

Hello everyone!

We had our first board meeting and finalized the Xmas party. Our VP will give a update at our next meeting.

We talked about possible tours, car shows, & about incorporating some historical stories of the club utilizing past Valley V8 newsletters.

That about all I have at this time. See you at the next meeting.

President Ernie Bailey

---

## CHAPTER 40 -- SAN FERNANDO VALLEY V-8'S CLUB MONTHLY MEETING MINUTES FOR

Valley V8 Minutes – Feb. 5, 2019 Meeting

Meeting was opened at 7:00 pm by President Ernie Bailey with the Pledge of Allegiance.

**Introduction of guests:** Clark Pomeroy of Calabasas, and newest member, with his '35 Pickup, which is in need of a windshield frame. He also owns 2 Model A's, and a '39 Ford Coupe. Also visiting is Al Mooney's son, Al Mooney Jr. Welcome to you both!

**Announcements:** With sadness Ernie reported on the passing of good friend and member Robert Zecher. A Memorial Service will be held for Robert on Feb. 23 at Forest Lawn, Glendale. Please drive your old Fords in his honor.

**Tours:** Ken Sapper is preparing a Tour of the Justice Private Auto Collection, in Duarte, for the Club in March. Dates are still being finalized and more information will be available at next meeting. Sign up sheet was passed around. If you are interested, please call Ken Sapper (818-326-1286) and get on the list!

Ken also announced the beginning of NASCAR season is upon us! Tune into the Daytona events at end of February and many more to follow. Root for our Ford teams!  
Ken also updated the club of the recovery of his stolen trailer and '32.

Ernie announced the upcoming Board Meeting to be held Feb. 12 at home of Steve Boskovich. Steve Boskovich then updated us on the Christmas Party plans for this year, 2019. As costs went up, it was decided to look around for another venue. If you can make any suggestion, please let Steve B. know. Report was given on Stan Miller's condition, as he has been hospitalized with heart surgery complications. Please keep him in your thoughts and prayers...get strong Stan...we miss you! Dues are due, please send your \$35 to Oliver Calibet and Sandrine ASAP so they can get the Roster for 2019 underway. 40 people still need to take care of this!

**Car of the Month:** went to Steve Boskovich and his '48 Sedan. (Chosen by new VP Jim Ellerbrock)

**Name Badge:** was awarded to Steve Boskovich (It's been 27 years since he last won!)

**Ladies Raffle:** was awarded to Sandrine Cutright and Joanie Sapper

Bobbie Searl announced February birthdays.

**50/50 Drawing:** was awarded to Oliver Calibet!

**Program:**– Larry Caplan introduced our speaker, Cliff McCool, with the Barrett-Jackson Auction Company. Raffle then proceeded, thanks to Steve Boskovich for bringing another great table-full of items.

Meeting was adjourned at 8:30 pm approximately. See you next month, March 5, "same bat time, same bat station!" per Ernie.

Submitted by Joan Sapper (filling in for Rex Jaramillo)

# The Valley V-8's 2019 Membership Application & Renewal Form

In order to continue to receive the Drivelines and remain in the roster...

Or to join our club...

**Please renew your membership by February 15, 2019**

Name: \_\_\_\_\_ Birthday Month: \_\_\_\_\_ Day: \_\_\_\_\_

Spouse: \_\_\_\_\_ Birthday Month: \_\_\_\_\_ Day: \_\_\_\_\_

Address: \_\_\_\_\_ City: \_\_\_\_\_ State & Zip \_\_\_\_\_

Phones - Home \_\_\_\_\_ Cell \_\_\_\_\_ Work \_\_\_\_\_

Email: \_\_\_\_\_

Occupation: \_\_\_\_\_

Year Joined: \_\_\_\_\_

Early Ford V-8 Vehicle(s) Owned - if same as prior year write "NO CHANGE"

<u>Year</u>	<u>Make</u>	<u>Model</u>	<u>Body Style</u>
_____	_____	_____	_____
_____	_____	_____	_____
_____	_____	_____	_____
_____	_____	_____	_____
_____	_____	_____	_____
_____	_____	_____	_____

**For Regional Membership:** Send a \$35.00 check - payable to: Valley V-8's

**Mail check to:** Valley V8's C/O Oliver Calibet 6732 Gaviota Ave., Lake Balboa, CA 91406

**If you have any questions please call 818-310-8571 Email: [sixty4500@gmail.com](mailto:sixty4500@gmail.com)**

**NOTE:** For us to meet insurance requirements, a Regional Group Member **MUST** also be a member of the Early Ford V-8 Club of America. Minimum membership is \$35.00 per year. Please contact me for mailing information or <http://www.earlyfordv8.org>