

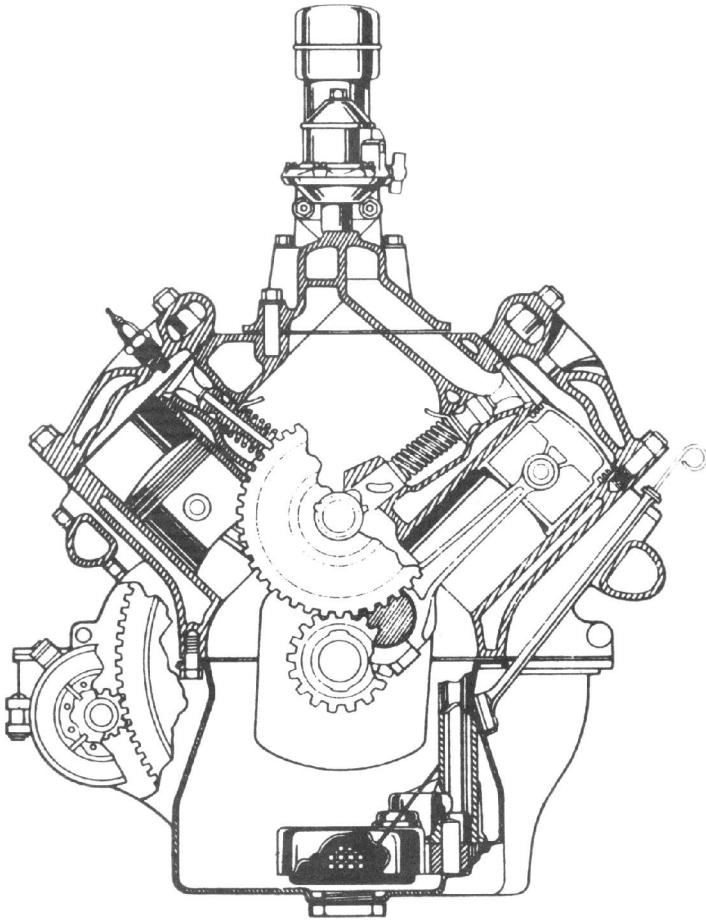

Drive Lines

Chapter #40
Our 49th Year
Visit Our Website
"valleyV8s.org"

Mar 2020



The Valley V8's
9700 Farralone, Chatsworth, Ca. 91311

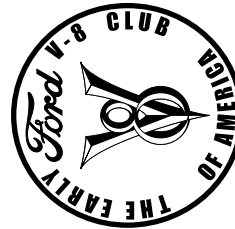

The Valley V's

2020

President	Ernie Baily	805-433-5540
Past Presidents	Vaskin Hagopian	323-661-2044
Vice President	Jim Ellerbrock	818-437-0412
Secretary	Rex Jaramillo	213-706-3854
Treasurer	Joan Sapper	818-249-5686
Tours	Kenney Sapper	818-249-5686
	Rich Carter	708-567-2393
Programs	Larry Caplan	818-363-2849
	Joe DiFatta	818-700-1939
Membership	Howard Brown	818-606-0267
	Joan Sapper	818-249-5686
Drive Lines	Robert Glucksman	818-618-1395
Prize Raffle	Steve Lehman	818-885-6938
50/50	Ken Sapper	818-380-5686
Ladies / Birthdays / Sunshine	Bobby Searl	818-353-6767
Name Badge	Karen Lehman	818-885-6938
Car of the Month	Jim Ellerbrock	818-437-0412
Web Master	Scott Dudrick	818-687-9836
Tech. Advisor	John Wolf	818-789-6201

Past Presidents

Jim Rowe	1971
Doug Peterson	1972
Don Durkee	1973-1974
Ed Warnock	1975
John Busk	1976
Chip Werstein	1977
Stan Misraje	1978
Bill Culp	1979
Al Spencer	1980
Larry Caplan	1981
Bob Rose	1982
Don Durkee	1983
Paul Kirk	1984
Kent Lowry	1985
Dave Sanborn	1986
John Kemmerer	1987
Dudley Ochsner	1988
Jerry Jensen	1989-1990
Joe DiFatta	1991
Chuck Shubb	1992-1993
George Richards	1994
Jerry Littner	1995
Dick Smith	1996
Chuck Mair	1997
Dennis Keene	1998
Rose Golt	1999
Don Stout	2000
Steve Boskovich	2001-2002
Joe DiFatta	2003
Wendi Potter	2004
Ken Sapper	2005-2006
Steven Batesole	2007
Harry Baker	2008-2009
Dave Bergman	2010
Randy Watson	2011-2012
Steve Boskovich	2013-2014
Stan Miller	2015
Don Durkee	2015
Vasken Hagopian	2016-2018
Ernie Baily	2019-????

Meeting: 1st Tuesday of the Month, 7:00p
 No host Dinner, Starting at 6:00p
 Rosie's BBQ & Grill, 8930 Corbin Ave.
 Northridge, Ca. 91324

Visit our Web Site: valleyv8s.org

Facebook: **Valleyv8s**

(<https://www.facebook.com/groups/579123315803014>)

Drive Lines is Published by
 The San Fernando V8's Regional Group 40
 of the Early Ford V8 Club of America
 9700 Farralone, Chatsworth, Ca. 91311

Our Next Meeting

Tues, 3 Mar 20

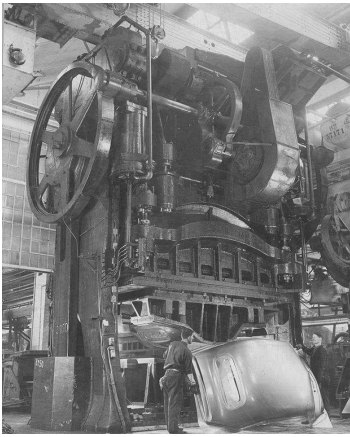

And now for some
"Pressing" News



Tickets for Long Beach Grand Prix:

Bill Green announced that he has
VIP tickets available for \$300 apiece.
These include best seats, hospitality tent, and much more.



**Ventura Early Ford V8 Club - 2020 Activity
Calendar**

March Meeting -Tues 17th

EVENT Sat 21st Spring Flower Day Drive
Lancaster & Boron Borax Mine
Tour, NASA Lunch & Blackbird
Airpark Exhibits Palmdale

April Meeting - Tues 21st

EVENT - Overnight Tour Carmel and Monterey
17 mile drive.
EVENT Sunday 26th Westlake Village Rotary
Street Fair & Classic/Exotic Car Show

"Your Ad Here"
For only \$5.00 a month,
YOU
can have your
business card ad
right here

For more details,
Please call or Email Rob at
818-882-2002, / madmodelr@aol.com
Please put "Drivelines" in the subject
Please make all payments to
"Valley V8 Club"



HELLO FELLOW MEMBERS

We would like to know more about You, Your Car...
So, What I would like from our members is a picture of you
with your car, with a small story. (1 Paragraph)
That way, We get to learn more about our members, & we
can put a face to a name & car

Please make all submissions to ether
"Drivelines" at madmodelr@aol.com, or
"Drivelines" 9700 Farralone Ave. Chatsworth, Ca. 91311

Thank You
Rob Glucksman, DL Editor

Great Western Container



SOLUTIONS IN PACKAGING AND GRAPHIC DESIGN

Steve Boskovich

Office (818) 341-2291
Cell (818) 903-6620
Fax (818) 341-1050

P.O. Box 4074
Chatsworth CA 91313



**SAN FERNANDO
VALLEY V8's
CHAPTER 40**

www.ValleyV8s.org

Meets first Tuesday of
the month at 7 p.m.

Rosie's BBQ

8930 Corbin Ave. • Northridge, CA 91324

**SPEEDWAY
ENGINEERING**



**Ken Sapper
President**

ken@1speedway.com
Office: 818.362.5865
Cell: 818.326.1286
Fax: 818.362.5608
13040 Bradley Avenue
Sylmar, CA. 91342
www.1speedway.com

Models Unlimited

Cars / Planes
Slot Cars
Figures
SciFi / Horror
Motorcycles
Buy / Sell
Old / New
Built / Unbuilt
Prototypes
Made to Order
We also carry Paints, Photo Etch,
AfterMarket, & Other Supplies
If we don't have it,
We can probably help you find it

**the MadModelr
Robert Glucksman
Chatsworth, Ca. 91311
office: 818-882-2002
cell: 818-618-1395
madmodelr@aol.com**



A Division of R.H. Factor Graphics

Program / Speaker

Cliff McKool & Howard Brown

Howard Brown: (Using the projector) showed the progress being made on the membership database. It will be used for record keeping and membership data such as due payment status, mailing and E-mail addresses, car model(s) owned, etc. When completed, members will be able to access certain areas for reference.

Cliff McKool: Talked about this year's Barrett Jackson's Scottsdale Auction. Close to 2000 cars were auctioned during the week plus a large amount of motorabilia. Cliff has been an employee of Barret Jackson for many years. They are now moving cars across the selling platform in minutes. Cliff also mentioned that the customs are now bringing more money than the muscle cars. Pick-ups are also bringing big money. (note: Cliff was recognized by the Motortrend announcers on air for his service and for keeping them all safe on stage).

Howard Brown: Howard was also in Scottsdale at the Russo and Steele Action where he drove numerous cars onto the selling platform. He described the various ways that they had to go through to start the cars. Another challenge to not hit the patrons that were walking in front of them and taking part in adult beverages. Howard then showed photos of some of the cars that he had driven, He also talked about visiting Barrett Jackson on Sunday. He observed the auction from the stage, (courtesy of Cliff) and showed photos of cars from Barret that he had seen.

~~~~~

Our program for the *March Meeting* will be presented by Ralph Hubbard who is a long time Early Ford V8 club member and a past National President. Ralph has been a certified appraiser of classic cars for many years and he will be telling us about the recent changes in values of our cars which should be of interest to everyone. His talks are always interesting and factual so you should plan on being with us to hear what he has to say.

Larry Caplan

---

### **FOR SALE, 1948 Ford Tudor Super Deluxe**

Very original, Black. I'm the 4th L.A. County owner f sold new in Nov. 1947 in Sunland. Only has 140,000 miles on it f the only non stock upgraded items include 12V conversion, turn signals, modern chrome wheels with 15ö B/W radial tires, headers with dual asexual and aluminum radiator (also comes with the original wheels, stock exhaust system, 16ö tires/wheels - which I kept). Recently fully rewired by Jerry Case (installed all available wire harnesses from C&G). Even the original dealer installed yellow fog lights work. The documentation of this survivor includes the original 1947 bill/sale (cost \$2,100 72 years ago), and some early service receipts, and years of DMV registrations. NO RUST. Runs great. Extra parts included are a windshield shade and rear fender skirts (not on car), some new window glass (with authentic w/ proper Ford factory logos) and some new window rubber f which were never installed. A rare very original survivor that is ready to drive and enjoy now. Radio and heater are all there, but not working.

**Asking \$20k. Steve Sadd. 310-508-0373 (cell)**



---

## **CAR OF THE MONTH**

**Jerry Littner** and **Oliver Calibet** volunteered to pick the car of the month. They chose **Ron Batesole's** 1935 5 window Coupe. Ron stated that he purchased the car back in 1975 in Sylmar. He updated the brakes along with other items. In 1980 the car was repainted in his driveway.

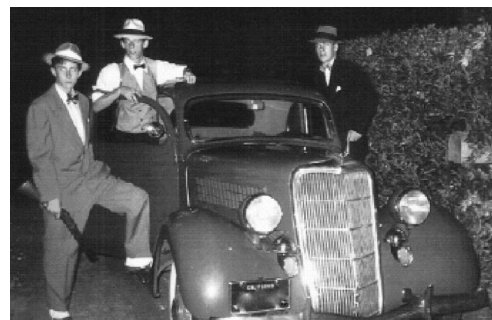

**CHAPTER 40 -- SAN FERNANDO VALLEY V-8's CLUB**  
**MONTHLY MEETING MINUTES FOR**  
*Continued*

**Car of the Month:**

**Jerry Littner** and **Oliver Calibet** volunteered to pick the car of the month.

**50/50 Raffle:** Handled by Vasken Hagopian filling in for Kenny Sapper

**Ladies Raffle and February Birthdays:** Bobbie Searl

**Name badge Raffle:** Karen Lehman

**Program Speakers:**

**Cliff McKool & Howard Brown:** Talked about this year's Barrett Jackson's Scottsdale Auction.

**Raffle:** Handled by Steve Lehman.

Meeting adjourned

---

---

**Member Bio,**

Prez Ernie Baily

Well, first off I was born in Cedar Rapids Iowa, Moved here to Canoga Park in 1959. When I was about 10 yrs old I started helping my Dad working on cars as he would buy and sell old cars to make extra money for the family. When I was 15 1/2 years old my Dad bought me my first car, a 1955 Dodge Custom Royal Hardtop for \$ 99.00. He and I worked on it, rebuilding the motor only to find out it had a cracked block. So we went to the Junkyard and found a 1958 Plymouth 318 V8 in a pile of old motors and then put it in the car. We then took it to Earl Scheib's and had it painted "Fire Engine Red" for \$29.95! Dad used the car as a second car until I turned 16 yrs old. Thats why I currently have a 55 Dodge now " to relive my youth!". I then had some other Mopars, 1960 Dodge Matador, and two 1964 Plymouth Sport Furys with the 426 wedge motor and 4 speed, one before I went into the Marine Corp in 1968 and another just before I got out of the service. After I got out I traded that one on a 1969 Plymouth Road Runner. I then a few years later bought a number of old cars to buy and sell trying to make extra money. I had wanted to build a Stock Car for Saugas Speedway but decided to lean toward Vintage car restoration due to the fact I knew nothing about racing business and sponsership costs. So I bought a 1947 Ford Pickup that was 1 week away from the crusher. I found it 3 blocks from my home which my Dad told me about. Paid \$75 and we drug it home with my Dads work backhoe. Well we no sooner get it up in the driveway, and my Dad says you have 1 month to get it drivable or its out of here! Then in the next minute he says to me "Let go to the Junkyard and get a Engine & Trans!". That leads me to April 1976 when I joined the "Valley V8 Club". And thats when I started working at Walt Disney Imagineering, which I worked for 27 years. One year later I married my wife Diane in April 1977 "The year Elvis died!" Throught the next few years I bought and sold some other old cars( 55 Imperial, 46 Ford 4dr (which I saved from a hippe that was going to cut the top off", It had the six and turned out to be a great car. I also bought a 1940 Ford "Opera" coupe and had that working great. About that time my wife and I had our son "Eric". I had to sell the 47 Pick up because we couldn't fit the car seat in the truck and have room to be able to go anywhere comfortably. I made some good money from the sale of the 47 Ford pickup. So I thought I could do two cars and bought a 1946 Ford Club Coupe and also bought my 48 Plymouth Special Deluxe which was just like my parents first car. Then I had used up all the money and had two nice running cars, but they looked bad. I decided to put them both up for sale and which ever sold first I would invest that money into the finishing the other. Well the 46 Ford sold first and then I took the money from that to invest in my 48 Plymouth, which was just like my Mom and Dads first new car. I then starting to look for another 55 Dodge, which was just like my first car. I now have had this 55 for almost 35 years,and the 48 Plymouth 40+ years. As you know I have been helping my brother with his cars. I continue to have interest in all vintage cars. I just tell everyone "I just want them All!"

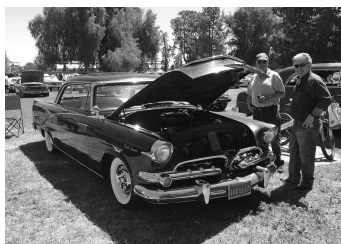

# From The President

Hello Everyone,

Hope everybody had a great Valentines Day! I hope all had a good time on the Reagan Tour. Now we have St. Patricks Day coming up which also happens to be my younger brothers birthday. I'm hoping to have his 56 Studebaker running and driving for his birthday March 17( it is his first car!).

I have decided to do the "Members Profile" on myself since I have procrastinated on calling on someone in the roster to submit one!

I'm putting together a list of possible tours for March that we can finalize at the meeting.

Look forward to seeing you all at the meeting!

Prez Ernie

---

---

## FROM THE EDITORS DESK

1st off,

Did the "Prez" Really say ..... "Studebaker"..... We'll let it slide, this time.....

NOW, to Buis....

Well, This newsletter is going to be a little different. We had people out....

To start, I left early, I was not feeling to good. Rex had something come up, I think the Sappers were at a show....

I will give it My best.... Rob / DLE

---

---

### CHAPTER 40 -- SAN FERNANDO VALLEY V-8'S CLUB

#### MONTHLY MEETING MINUTES FOR

Tuesday, February 4, 2020

#### 7:00 PM: Meeting called to order

President Ernie called the meeting to order and led us in the Pledge of Allegiance

#### Guest Introductions:

Peter and Andrea Scott, (contacted by Steve Boskovitch).

Steve Hedke, (friend of Howard Brown from the Studebaker Club. Steve has participated in numerous Hemmings Great Races and placed third in his class in the 2019 Event).

#### Announcements:

1) Ernie made the sad announcement that two of our past Presidents, Dave Sanborn and Bob Rose, had passed.

Jerry Littner, Vasken and Ernie gave their memories:

**Dave Sanborn:** Multiple comments on Dave's openness to assist members in their projects and to give advice. He published the Drivelines was also an expert authority on '35 Fords (especially roadsters). He was a runner. Dave also appreciated the visits that were made after falling ill.

**Bob Rose:** Described as quiet and calm man. He became a dentist and because of his color, had a hard time finding work or establishing his own practice. He then found employment as a Dentist in the prison System. Bob was also a member of the famous "Tuskene Airmen" and authored a book.(name?)

2) Ernie then gave a brief review of the issues discussed at the Board Meeting that was held at his place on Jan. 16<sup>th</sup>

Tours:

Digital Upgrade:

Merchandise:

Car of the Month:

3) Due to work commitments and travel, Oliver and Sandrine are stepping down as Membership / Directory personnel. Thanks to both of them for their time serving the club. Howard Brown is the new Membership contact.

4) **Bill Green:** Long Beach Grand Prix package tickets are still available.

5) **Al Mooney:** Arrived later for the meeting. He had been watching the President's State of the Union Speech. Stated how we should all be proud to live in America. Led us all in singing "God Bless America".

7:22 Break called, meeting resumed at 7:45.





**The Valley V-8's  
2020 Membership Application & Renewal Form**

**In order to continue to receive the Drivelines and remain in the roster**

**Or to join our club**

**Please renew your membership by February 15, 2020**

**Name:** \_\_\_\_\_ **Birthday Month:** \_\_\_\_\_ **Day:** \_\_\_\_\_

**Spouse:** \_\_\_\_\_ **Birthday Month:** \_\_\_\_\_ **Day:** \_\_\_\_\_

**Address:** \_\_\_\_\_ **City:** \_\_\_\_\_ **State & Zip** \_\_\_\_\_

**Phones - Home** \_\_\_\_\_ **Cell** \_\_\_\_\_ **Work** \_\_\_\_\_

**Email:** \_\_\_\_\_

**Occupation:** \_\_\_\_\_

**Year Joined:** \_\_\_\_\_

**Early Ford V-8 Vehicle(s) Owned - if same as prior year write "NO CHANGE"**

| <u>Year</u> | <u>Make</u> | <u>Model</u> | <u>Body</u> | <u>Style</u> |
|-------------|-------------|--------------|-------------|--------------|
|-------------|-------------|--------------|-------------|--------------|

|  |
|--|
|  |
|  |
|  |
|  |
|  |
|  |

**For Regional Membership: Send a \$35.00 check - payable to: Valley V-8's**

**Mail check to: Valley V8Es C/O Howard Brown, 20036 Tuba St. Chatsworth, Ca.  
91311**

**If you have any questions please call 818-606-0267 Email: brngarage@gmail.com**

**NOTE: For us to meet insurance requirements, a Regional Group Member MUST also be a member of the Early Ford V-8 Club of America. Minimum membership is \$35.00 per year. Please contact me for mailing information or <http://www.earlyfordv8.org>**