

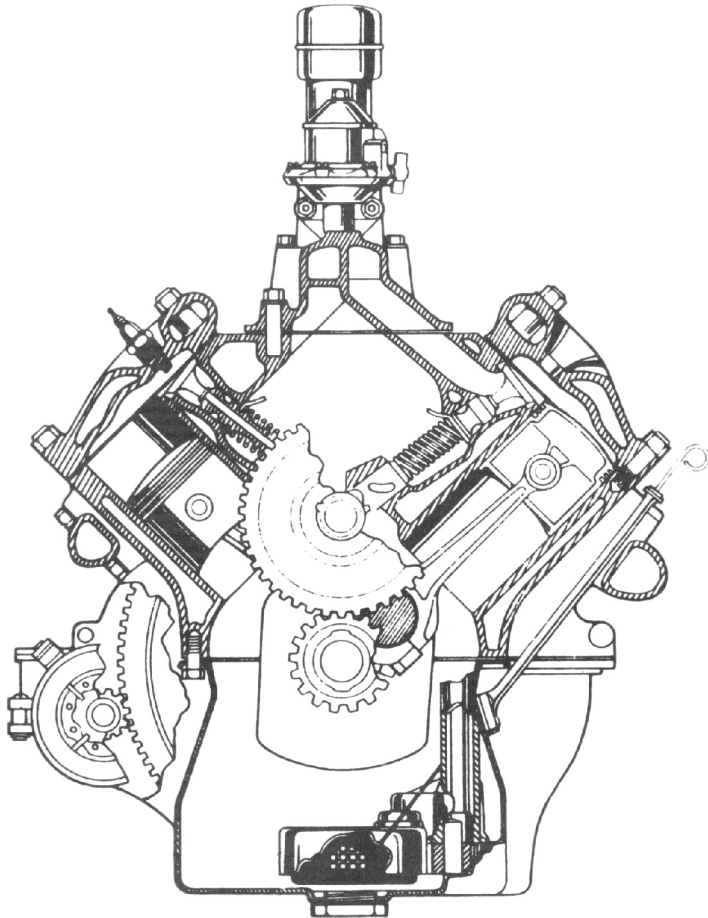

Drive Lines

Chapter #40
Our 48th Year
Visit Our Website
"valleyV8s.org"

Apr 2019



The Valley V8's
9700 Farralone, Chatsworth, Ca. 91311

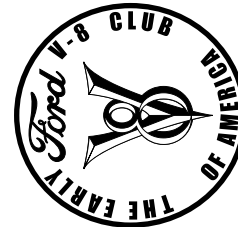

The Valley V's

2019

President	Ernie Baily	805-428-0558
Past Presidents	Vaskin Hagopian	323-661-2044
Vice President	Jim Ellerbrock	818-437-0412
Secretary	Rex Jaramillo	213-706-3854
Treasurer	Joan Sapper	818-249-5686
Tours	Kenney Sapper	818-249-5686
	RichCarter	708-567-2393
Programs	Larry Caplan	818-363-2849
	Joe DiFatta	818-700-1939
Membership	Sandrine Cutright	310-804-7790
	Oliver Calibet	818-310-8571
	Joan Sapper	818-249-5686
Drive Lines	Robert Glucksman	818-618-1395
Prize Raffle	Steve Boskovich	818-341-6876
50/50	Ken Sapper	818-380-5686
Ladies / Birthdays / Sunshine	Bobby Searl	818-353-6767
Name Badge	Karen Lehman	818-885-6938
Car of the Month	Jerry Jensen	805-491-3355
Web Master	Scott Dudrick	818-687-9836
Tech. Advisor	John Wolf	818-789-6201

Meeting: 1st Tuesday of the Month, 7:00p
 No host Dinner, Starting at 6:00p
 Rosie's BBQ & Grill, 8930 Corbin Ave.
 Northridge, Ca. 91324

Visit our Web Site: valleyv8s.org

Facebook: **Valleyv8s**

(<https://www.facebook.com/groups/579123315803014>)

Drive Lines is Published by

The San Fernando V8's Regional Group 40
 of the Early Ford V8 Club of America
 9700 Farralone, Chatsworth, Ca. 91311

The Valley V's

Past Presidents

Jim Rowe	1971
Doug Peterson	1972
Don Durkee	1973-1974
Ed Warnock	1975
John Busk	1976
Chip Werstein	1977
Stan Misraje	1978
Bill Culp	1979
Al Spencer	1980
Larry Caplan	1981
Bob Rose	1982
Don Durkee	1983
Paul Kirk	1984
Kent Lowry	1985
Dave Sanborn	1986
John Kemmerer	1987
Dudley Ochsner	1988
Jerry Jensen	1989-1990
Joe DiFatta	1991
Chuck Shubb	1992-1993
George Richards	1994
Jerry Littner	1995
Dick Smith	1996
Chuck Mair	1997
Dennis Keene	1998
Rose Golt	1999
Don Stout	2000
Steve Boskovich	2001-2002
Joe DiFatta	2003
Wendi Potter	2004
Ken Sapper	2005-2006
Steven Batesole	2007
Harry Baker	2008-2009
Dave Bergman	2010
Randy Watson	2011-2012
Steve Boskovich	2013-2014
Stan Miller	2015
Don Durkee	2015
Vasken Hagopian	2016-2018
Ernie Baily	2019-????

"Your Ad Here"
For only \$5.00 a month,
YOU

can have your
business card ad
right here

For more details,
Please call or Email Rob at
818-882-2002, / madmodelr@aol.com
Please put "Drivelines" in the subject
Please make all payments to
"Valley V8 Club"



HELLO FELLOW MEMBERS

We would like to know more about You,
Your Car...

So, What I would like from our members is
a picture of you with your car, with a small
story. (1 Paragraph)

That way, We get to learn more about our
members, & we can put a face to a name &
car

Please make all submissions to ether
"Drivelines" at madmodelr@aol.com, or
"Drivelines" 9700 Farralone Ave.

Chatsworth, Ca. 91311

Thank You

Rob Glucksman, DL Editor

Our Next Meeting

Tues, 2 Apr 19

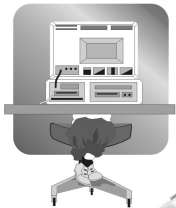

R.H.FACTOR GRAPHICS

*Computer Graphics
Desktop Publishing*



For all your Pre-Press needs

Robert Glucksman
Chatsworth, Ca. 91311
Office: 818-882-2002
Cell: 818-618-1395
madmodelr@aol.com

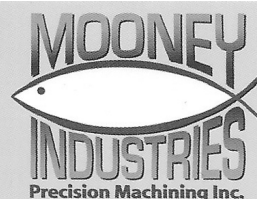

8744 REMMET AVE.
CANOGA PARK, CA 91304
(818) 998-0199
FAX (818) 341-2073

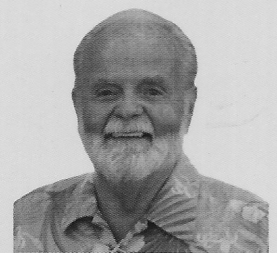

AL MOONEY
C.F.O.

al@mooneyindustries.com

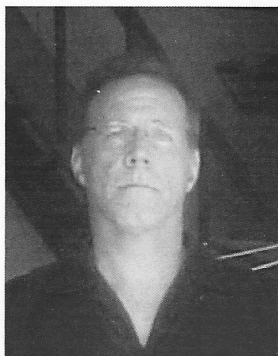

ARBONNE.
INDEPENDENT
CONSULTANT

Steven Lehman
Arbonne Independent Consultant
Consultant
23592171

Reset, Restore, Rebalance
Discover Ultimate Health,
C 818.517.1268

ArbonneForever@yahoo.com
www.stevenlehman.arbonne.com

SPEEDWAY ENGINEERING



Ken Sapper
President
ken@1speedway.com
Office: 818.362.5865
Cell: 818.326.1286
Fax: 818.362.5608
13040 Bradley Avenue
Sylmar, CA. 91342
www.1speedway.com

CAR OF THE MONTH

Handled by VP Jim Ellerbrock

Due to the Rains, there was, No "Car of the Month"

Rob / DLE

Program / Speaker

Program: Our very own Jim Kelly was our speaker. And what a speaker he was! Jim has had an amazing life. Starting 93 years ago, Jim hit the streets running and hasn't slowed a bit. He's got a bucket list and said he's only finished half of it! Well, after hearing the account of his life, it's been a full one, and there's more to come. For starters, Jim was born in Pittsburgh, PA. One of his first memories as a young kid was big, fast cars, we're talking along the lines of Cadillacs, Packards, and Lincolns. Jim said his Dad was a real people-person; (appears to have been handed down, from all accounts!) and did real well in the world of sales. This afforded Jim and his brothers opportunities to attend trade fairs with ol' Dad, where, for young Jim, the love of big, heavy, fast cars grew. He recalls riding in the family 'chauffer'-bodied Lincoln with his Mom and Dad in front, the chauffer window rolled up, and the boys in the back 'rough-housing' as the parents' drove blissfully unaware. He also remembers a 'barber shop' in Chicago with a bunch of big Lincolns, Packards, and Cadillacs parked nearby. It turned out to be a front for a 'speakeasy' frequented by mobsters, the likes of Al Capone. Fast-forward to 1942, when Jim's older brother, an airman in the U.S. Army Air Corp, arranged for the purchase of a 1941 Ford convertible at the 'request' of his superior, a Captain. After purchase in Chicago, to save shipping and handling, the older brother, Jim, and a younger brother drove the '41 from Chicago to Santa Ana for delivery to the Captain. Young and daring, they set out in high spirits, driving at night to avoid the heat. Often, because of the gas rationing and short fuel range of that 24-stud flathead, they had to stop in the wee hours of the morning and wait for gas stations to open. But they made it, and quite a trip it was! When they arrived to Santa Ana, the Captain had been transferred to Sacramento, so Jim had to drive the '41 up there, solo, using Auto Club maps, because Jim's brother had to report for duty. When young Jim arrived in Sacramento, the good Captain was elusive about paying Jim for the car '...give me the keys, I'll send you the money...' Now that response didn't cut it for this seasoned kid from Chicago, and Jim stood his ground. Well the Captain finally paid, even gave him some gas money! After that, Jim used Auto Club maps and hitchhiked back to Santa Ana, quite an adventure! Fast-forward again: Jim's professional worklife in design engineering and sales was also quite interesting. At one point, Jim worked for Harvey Aluminum. While there, he became convinced that lightweight extruded aluminum was better in racing applications than steel with holes drilled. About the same time, he met a fellow named Mickey Thompson. The rest is history, all the way to the Harvey Aluminum Special, that mid-engine aluminum Buick 215 V-8, driven by Dan Gurney at the 1962 Indy 500. Yes, Jim was at the forefront of this Indy venture, and so much more. In summary, this is our man Jim Kelly, a car guy, a real adventurer, our very own fellow V-8 Club member faithfully serving over the years, a can-do-guy, Jim, you're the best, thanks for sharing!

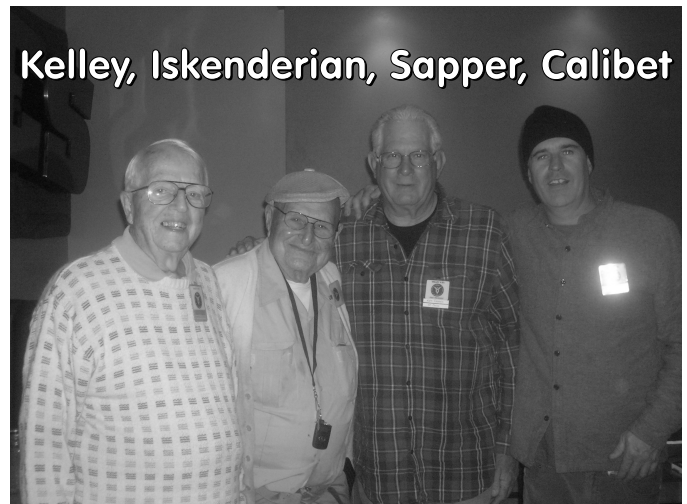
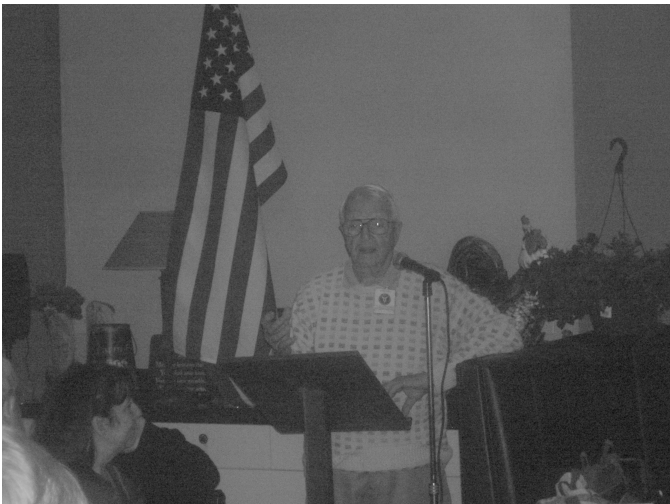

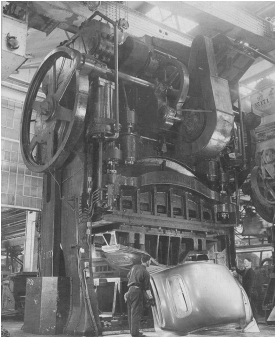

*And now for some
"Pressing" News*

NEW MEMBERS

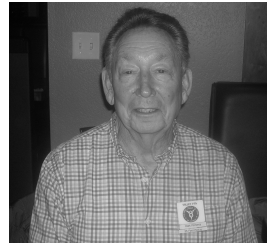

Lets welcome New Member, Mr. Clark Pomeroy, to our Ford V8 Family

My interest in old cars started at age 11 when I bought my first Model "A", a 1928 Ford Special Coupe.

I currently have a 1928 Ford AR tudor and a 1930 Ford Coupe Deluxe.

I have been a member of the San Fernando Valley Model "A" ford Club for nine years and was President for two years.

My latest project is a 1935 Ford Pickup V8 which I have been working on for the past year and the reason I have joined the V8 Club.

I look forward to becoming better aquatinted with the membership and to learn more about the early Ford V8 Cars and Trucks.

I have lived here in the Valley all my life, went to Poly High School and am retired from a 43 year career in the restaurant business with Marie Callender's Pies



It's time again for the Coffee n Kix Reunion on Saturday, April 6th, 8:00 AM. Come see the great cars and enjoy the Coffee n Donuts. Stop by and say Hi.



CHAPTER 40 -- SAN FERNANDO VALLEY V-8'S CLUB MONTHLY MEETING MINUTES FOR Continued

7:20 pm: Break called 7:30 pm: Meeting resumed

Lady's raffle: Handled by Bobbie Searl, won by Bobbie Searl (not fixed) and Karen Lehman.

Birthdays for March: Handled by Bobby Searl: The following were recognized: Ruth Mottern 18. Ed Warnock 18. Richard Stones 25. Harry Baker 28. Robert Glucksman 29.

Name Badge Drawing: Handled by Karen Lehman, won by Don Stout.

50/50 Drawing: Handled by Ken Sapper, won by Reenie Jaramillo.

Program: Our very own Jim Kelly was our speaker. And what a speaker he was! Jim has had an amazing life.

Raffle: Steve Boskovich: Many nice gifts were won by some very grateful people, thanks Steve for conducting our Raffle.

President Ernie -- Closing Comments: At our meeting, Ernie had a V-8 Club banner displayed that had been made in 1977. Nice work, Ernie, keeping it all of those years, knowing it might be used again. Next meeting: Apr 2

8:40 pm: Meeting adjourned.

From The President

Hello All,

We had a great meeting on a rainy night. Jim Kelly talked about the past with his father and working with the great Mickey Thompson. I had no idea about Mickey Thompson's efforts to compete in the Indy 500 race.

I received a copy of the National V8 Club Board meeting notes. Here are some highlights from them. The Early Ford V-8 Foundation and Museum will be dedicated on May 10, 2019 at the newly expanded complex in Auburn, Indiana. Also the Dan Wittern claim of misuse of club funds has been settled with a full recovery of \$472 thousand dollars with \$50 thousand dollar insurance coverage. Phil Hall has retired and his wife Connie has taken over the position of California/Southwest 3 director.

I'm looking forward to the upcoming Justice Bros. tour along with some good weather. Hope to see you all there! Also remember April 7th is the Poppy Tour with the Corvair Club. I'm planning on joining in on the tour (Approx 100mile drive). Hope to see some members join me! Give me a call if there are any questions about it.

That's about all I have at the moment. See you all next meeting!

Ernie Baily

CHAPTER 40 -- SAN FERNANDO VALLEY V-8'S CLUB MONTHLY MEETING MINUTES FOR Tuesday March 5, 2019

7:00 pm: Meeting called to order

President Ernie Bailey opened the meeting, welcomed the group, led us in the Pledge of Allegiance.

Guest Introductions: The following people were introduced as our guests: Dale and Shari Schirmester, and Dale's dad Gil, owners of the iconic Gil's muffler Shop, also guest John Coonan from Wisconsin, and our own Ed 'Isky' Iskenderian.

Comments from our President:

Ernie talked about our annual new-year Board meeting held recently. Handing out Club business cards was discussed, along with ideas for tours. Then Ernie mentioned a past member Paul Minsky, who called with an idea of us teaming up with the Corvair Club on a Poppy field tour. It's going to be a good year!

Steve Boskovich followed up with the account of a Car Show that he and Joe DiFatta attended 29 years ago. They met Jim Kelly, gave him a V8 Club calling card, and the rest is history, as the saying goes.

Reports from Officers:

Secretary Rex Jaramillo: Was gone for a few months, not because of a bad back, actually he was night-teaching Auto Tech at Pasadena Community College. Now he has a morning assignment. Rex thanked Joan Sapper for doing such a good job taking the Meeting Minutes, and Robert Glucksman for his most excellent editing.

Membership/Club Directory Oliver Calibet and Sandrine Cutright: Thanks to all who paid their 2019 Club on time. Unfortunately there are a few Club members who haven't submitted their dues yet. This needs to be handled so that their names remain in the 2019 Membership Directory.

Treasurer -- Joan Sapper: Everything OK. Joan gave a Club financial report.

Tours -- Ken Sapper: Friday March 22: Justice Brothers tour. Ken and Rich Carter passed a sign-up sheet around. Meet 8:30 am at the parking lot, UA theatre in Montrose. The theatre is near the Verdugo Hills Hospital. This is going to be a swell tour!

Drive Lines Editor -- Robert Glucksman: Everything OK.

Vice President -- Jim Ellerbrock: Mentioned that the Christmas party would be held on December 1, 2019, same place as last year, Knollwood Country Club.