

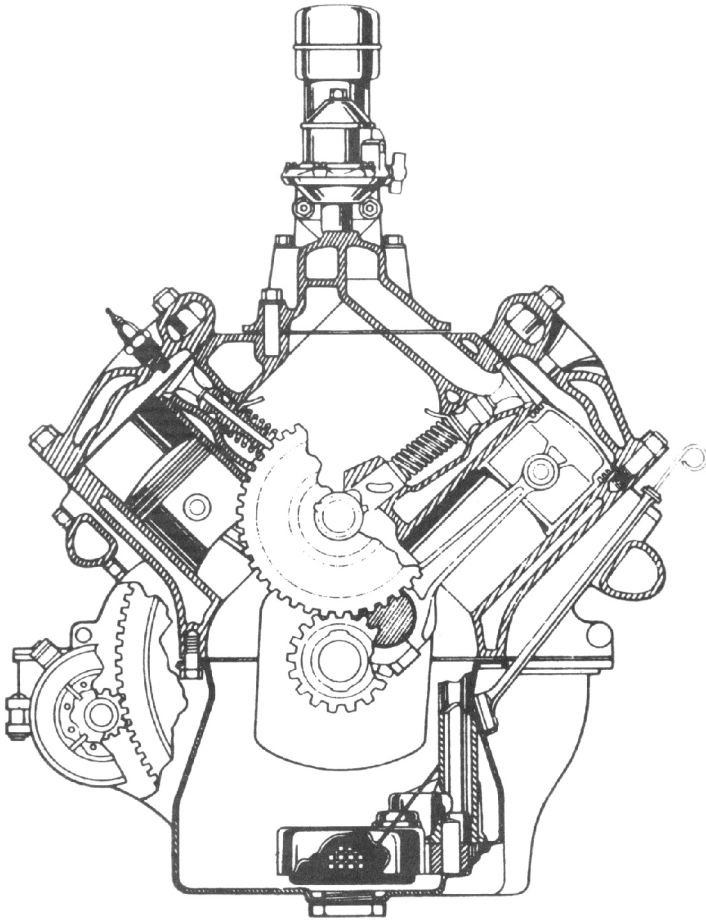

Drive Lines

Chapter #40
Our 48th Year
Visit Our Website
"valleyV8s.org"

May 2019



The Valley V8's
9700 Farralone, Chatsworth, Ca. 91311

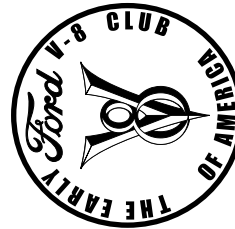

The Valley V's

2019

President	Ernie Baily	805-428-0558
Past Presidents	Vaskin Hagopian	323-661-2044
Vice President	Jim Ellerbrock	818-437-0412
Secretary	Rex Jaramillo	213-706-3854
Treasurer	Joan Sapper	818-249-5686
Tours	Kenney Sapper	818-249-5686
	RichCarter	708-567-2393
Programs	Larry Caplan	818-363-2849
	Joe DiFatta	818-700-1939
Membership	Sandrine Cutright	310-804-7790
	Oliver Calibet	818-310-8571
	Joan Sapper	818-249-5686
Drive Lines	Robert Glucksman	818-618-1395
Prize Raffle	Steve Boskovich	818-341-6876
50/50	Ken Sapper	818-380-5686
Ladies / Birthdays / Sunshine	Bobby Searl	818-353-6767
Name Badge	Karen Lehman	818-885-6938
Car of the Month	Jerry Jensen	805-491-3355
Web Master	Scott Dudrick	818-687-9836
Tech. Advisor	John Wolf	818-789-6201

Meeting: 1st Tuesday of the Month, 7:00p
 No host Dinner, Starting at 6:00p
 Rosie's BBQ & Grill, 8930 Corbin Ave.
 Northridge, Ca. 91324

Visit our Web Site: valleyv8s.org

Facebook: **Valleyv8s**

(<https://www.facebook.com/groups/579123315803014>)

Drive Lines is Published by

The San Fernando V8's Regional Group 40
 of the Early Ford V8 Club of America
 9700 Farralone, Chatsworth, Ca. 91311

The Valley V's

Past Presidents

Jim Rowe	1971
Doug Peterson	1972
Don Durkee	1973-1974
Ed Warnock	1975
John Busk	1976
Chip Werstein	1977
Stan Misraje	1978
Bill Culp	1979
Al Spencer	1980
Larry Caplan	1981
Bob Rose	1982
Don Durkee	1983
Paul Kirk	1984
Kent Lowry	1985
Dave Sanborn	1986
John Kemmerer	1987
Dudley Ochsner	1988
Jerry Jensen	1989-1990
Joe DiFatta	1991
Chuck Shubb	1992-1993
George Richards	1994
Jerry Littner	1995
Dick Smith	1996
Chuck Mair	1997
Dennis Keene	1998
Rose Golt	1999
Don Stout	2000
Steve Boskovich	2001-2002
Joe DiFatta	2003
Wendi Potter	2004
Ken Sapper	2005-2006
Steven Batesole	2007
Harry Baker	2008-2009
Dave Bergman	2010
Randy Watson	2011-2012
Steve Boskovich	2013-2014
Stan Miller	2015
Don Durkee	2015
Vasken Hagopian	2016-2018
Ernie Baily	2019-????

"Your Ad Here"
For only \$5.00 a month,
YOU

can have your
business card ad
right here

For more details,
Please call or Email Rob at
818-882-2002, / madmodelr@aol.com
Please put "Drivelines" in the subject
Please make all payments to
"Valley V8 Club"



HELLO FELLOW MEMBERS

We would like to know more about You,
Your Car...

So, What I would like from our members is
a picture of you with your car, with a small
story. (1 Paragraph)

That way, We get to learn more about our
members, & we can put a face to a name &
car

Please make all submissions to ether
"Drivelines" at madmodelr@aol.com, or
"Drivelines" 9700 Farralone Ave.

Chatsworth, Ca. 91311

Thank You

Rob Glucksman, DL Editor

Our Next Meeting
Tues, 7 May 19

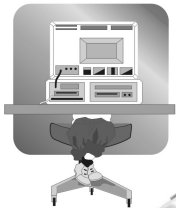

R.H.FACTOR GRAPHICS
*Computer Graphics
Desktop Publishing*



For all your Pre-Press needs

Robert Glucksman
Chatsworth, Ca. 91311
Office: 818-882-2002
Cell: 818-618-1395
madmodelr@aol.com



8744 REMMET AVE.
CANOGA PARK, CA 91304
(818) 998-0199
FAX (818) 341-2073

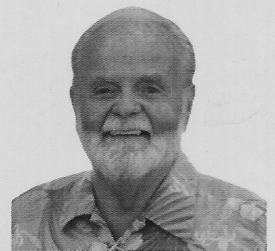

AL MOONEY
C.F.O.

al@mooneyindustries.com

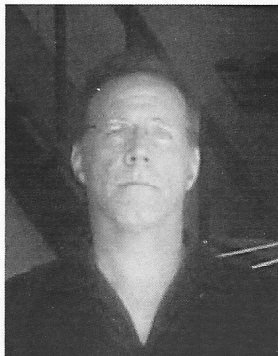

ARBONNE.
INDEPENDENT
CONSULTANT

Steven Lehman
Arbonne Independent Consultant
Consultant
23592171

Reset, Restore, Rebalance
Discover Ultimate Health,
C 818.517.1268

ArbonneForever@yahoo.com
www.stevenlehman.arbonne.com

**SPEEDWAY
ENGINEERING**



Ken Sapper
President
ken@1speedway.com
Office: 818.362.5865
Cell: 818.326.1286
Fax: 818.362.5608
13040 Bradley Avenue
Sylmar, CA. 91342
www.1speedway.com

CAR OF THE MONTH

Handled by Jerry Jensen

Car of the month: Handled by Jerry Jensen, honors go to Al Mooney and his oh-so-fine 1953 Mercury convertible. The car is quipped with the venerable Merc flathead and the Merc-o-Matic transmission. Al mentioned that the car was manufactured while he was still in high school. And coincidentally, Al bought the '53 when he was 53 years old. At that time, the car was in Chicago, advertised in an Old Car News. When Al phoned, the owner mentioned that some people would be there on Saturday to look at it. Al said '...no problem I'll be there on Friday'. The Merc was yellow at the time, and Al knew before the garage door was halfway up that this was 'the car'. After purchase, Al drove it back from Chicago in January, pretty gutsy! Yellow is nice, but red is cool, so Al had the Merc re-sprayed in that rebel-rousin' red! This blends nicely with the red leather interior. And Al still drives the car often, that 255-inch 8CM mill pulls just fine! And it's been known to haul celebrities, among them Ronald McDonald! Congratulations, nice car Al, very deserving for April Car of the Month.



Program / Speaker

Program: Larry Kaplan introduced our guest speaker, Tony Baron. What an amazing guy! Tony is an Instructor in the Auto Technology Department at Cerritos College. He runs the Ford Corporate training program at the College, actually established the Program there. Tony has quite a background. He's worked at independent repair shops including some owned by his dad. He also worked for Ford and GM dealerships as mechanic, shop foreman, service writer, service manager, he ran a repair shop in West LA for the FBI, got drafted, served in the military, man, he's done it all! But to cap it off, Tony has one of the most interesting 'other' jobs in the world: He owns a speed equipment manufacturing business specializing in Ford V-8 flathead. Now Tony has good roots. It started with his dad Frank Baron. At twelve years old, young Frank created his first hot rod, a Model T coupe which he chopped and installed a Rajo O.H.V. conversion. Around 1937, Frank opened his first shop, Baron's Automotive Service. During that time, he and another hot rod great Tommy Thickstun collaborated on specialized speed equipment for the Ford V-8. This amazing team did research and sought to resolve such issues as cylinder heads that would allow for high compression and proper 'breathing'. After WW II, Frank teamed up with yet another hot rod great, Bob Tattersfield, to lay the foundation for a line of racing equipment intended for the Ford V-8. So Tony comes from a line of racing greats and is keeping the tradition alive with his fine line of Ford flathead V-8 speed equipment. This includes cylinder heads used by the best of them at El Mirage, Bonneville, and drag racing where 'only the best' will do. Tony also manufactures intake manifolds, fuel blocks, air cleaners, and velocity stacks. His company has recently expanded and now makes reproduction Thickstun intakes for Dodge and Chevy, also for the GMC 302.

So what cars has Tony had? Well, his first was a '36 Ford coupe purchased in 1959 even before he had a drivers' license. It had a 21-stud flathead, that came out quickly and in its place went a full-house 59AB mill with four-pot intake. That '36 was quite a car, fast, but fully restored and graced with a Tony Nancy interior.

There were many other cars after that, but the one most memorable and one that he still owns started life in 1950. It's a '27 'T roadster that Tony bought from Bill Norton, originally built by Lou Banta in 1950. Now this 'T had some distinction, it was a Car Craft magazine cover car in 1954, and a Motor Trend Hot Rod show car from 1952 through 1954. About the time Tony bought the 'T, he was getting into the dry lakes and Bonneville racing scene. And the SCTA had just decided to re-instate the flathead racing class. So Tony turned that 'T into a race car. It was highboy-style on deuce rails with a '32 grille shell, A full belly pan was added and other bodywork completed to streamline things, all crafted by Michael Scott, premier 'tin-bender'. Tony raced the roadster at Bonneville for the first time in 1976. Running on alcohol, he ran 143 mph After some other tweaks including fuel injection, he turned a best of 154 mph. Following the Bonneville adventures, Tony pulled the roll cage, drove the 'T on the street for awhile, then parked it in his garage, where it's been resting, not driven since 1980.

Now here's the best part:

This piece of hot rod history is presently for sale! Contact Tony if you're interested.

In summary, what a program! As mentioned, Tony has the most interesting 'side job' in the world. Tony, we appreciated your presentation and your handouts were swell as well!



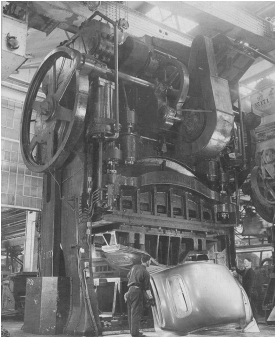

*And now for some
"Pressing" News*

Apologies to Al Mooney, who's name was omitted from the directory. We are printing his name on a label to place in the directory

Thank You
Rob / DLE

NEW MEMBERS

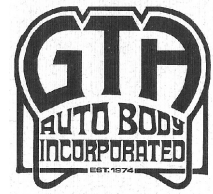

Doug Peterson
President
818-349-4920
Fax: 818-718-1867
COMPLETE COLLISION REPAIRS
FOREIGN & DOMESTIC
20115 Nordhoff St.
Chatsworth, Ca. 91311
doug@gtaautobody.com

CHAPTER 40 -- SAN FERNANDO VALLEY V-8'S CLUB
MONTHLY MEETING MINUTES FOR
Continued

Tours -- Ken Sapper: Announced the annual Old Fashioned Day in the Park. This will be held on July 28 in Marina Del Rey. It's that Event that Gerard and Pam Buck help with, includes a car show, tours of sailboats, free continental breakfast, a fantastic event not to miss!

Vice President -- Jim Ellerbrock: Shared information about our next month's guest speaker: Denny Tedesco. Denny is the son of Tommy Tedesco, member of the Wrecking Crew, backup band for many famous 1960's rock'n roll groups. Tommy Tedesco has been billed as the most recorded guitarist in history. Jim mentioned it would be good to see the movie 'The Wrecking Crew' ahead of our May meeting to give Denny's talk more meaning.

Drive Lines Editors Rob Glucksman: All good.

Membership/Directory Oliver Calibet & Sandrine Cutright: All good. Oliver announced the All-Ford Car show, Sunday April 14 at Angel's Stadium. He also distributed the latest Valley V-8 Directory 2019, nice job, Oliver and Sandrine!

7:25 pm: Break called 7:50 pm: Meeting resumed

Car of the month: Handled by Jerry Jensen, honors go to Al Mooney and his oh-so-fine 1953 Mercury convertible.

Ladies raffle: Handled by Lynn Carter who stepped in for Bobbie Searl, missed you, Bobbie. Beautiful plants were won by Joyce Mooney and Joan Sapper

Birthdays for April: Terry Brightson and Terry Reitz 1, Grace Clark 4, Sally Colarossi 13, Sharon Glucksman 14, Howard Brown 16, Steve Lehman 27, Harvey Jacobs 28.

Name Badge: Handled by Karen Lehman, won by Dick Colarossi

50/50 Drawing: Handled by Ken Sapper, won by Whitney Rydbeck.

Program: Larry Kaplan introduced our guest speaker, Tony Baron. What an amazing guy!

Raffle: Steve Boskovich: Many nice gifts were taken home tonight, thanks Steve for conducting our Raffle.

Steve Boskovich: June is 'drive an old car' month. And remember Don Stout's Coffee & Kix Saturday April 6.

8:55 pm: Meeting adjourned.

From The President

Hello, Everyone,

We had a great meeting last month and it looks like we will have another good one this month. I wanted to start off by telling you all we had a fun "Poppy Run" with the Corvaair club. I drove my 55 Dodge and Ken & Joan Sapper joined me with "Franks Dream" past member Frank Deinys 26-27 T roadster with a great sounding Flathead V8. Ken told me the day before they drove it up to Mt. Wilson with the grand kids riding in the rumble seat(I always wanted to do that!). I followed them in my car with all the windows down "Hardtopping It". The weather was just Great! The Poppys were out still and in some cases they looked like blankets over the hills! We did run into some traffic, right by the Poppy reserve, but other than that we had a real nice cruise.

I'm hoping to have another Board Meeting in May so we can plan some more cruises. If anyone has ideas on where we can go for a driving tour, please let me or Ken Sapper know so we can look into it.

Well! Thats all I have at the moment! Weather is getting real nice! Finely! So "Drive your V8s" to the next meeting if you can!

See you at the Meeting!

Ernie Baily

CHAPTER 40 -- SAN FERNANDO VALLEY V-8'S CLUB MONTHLY MEETING MINUTES FOR

Tuesday April 2, 2019

7:00 pm: Meeting called to order

President Ernie Baily opened the meeting, welcomed the group, led us in the Pledge of Allegiance.

Guest Introductions: The following people were introduced as our guests: David Grant, Doug Peterson, (son of Doug Peterson Sr., one of the founding member's of our Club). Whitney Rydbeck was back, he's a Club member, starred in the TV series Whitney and the Robot, remember his 1946 Ford taxi?

Comments from our President: Ernie Baily

Justice Brothers Museum tour: On Friday morning, March 22, many Club members gathered in Duarte, some cruising out in their old Fords, for a rare treat: A personal tour of the Justice Brothers Museum, provided for us by none other than Ed Justice. And what an amazing tour! From oval-track midget racecars to old-school 'digger'-style dragsters to celebrity star cars, even a racing airplane and so much more, the Justice Brothers Museum has it all. 'Insiders' information and detail abounded from Ed Justice, he's the 'real deal'. During the tour, President Ernie shared that his dad was chief mechanic on a pit crew in midget car racing. After the tour, the group went to the local Spaghetti Factory for a delicious lunch, food and service was just swell. But always the challenges! Afterwards, in the parking lot, Ernie was putting his brother and wheelchair into the van and the door/lift mechanism went haywire. Between resourceful Club members and Auto Club, they were able to get the wheelchair in. The next challenge: Unloading at home. After a try with some steel ramps, no luck, Ernie used a piece of plywood. It flexed, creaked and cracked, but it held! In summary, the Justice Brothers Museum tour was a day of adventure in so many ways. Thanks to Ken and Joan Sapper, also Rich and Lynn Carter for setting it up for us. **Poppy Run update:** Ernie mentioned that plans were still in place for this Event: April 7 is the date. Meet at Trader Joe's in Balboa. **Saugus Speedway Reunion:** This was held Saturday March 30 at Irwindale Speedway in conjunction with their K&N Can Am series, skid-plate, figure 8, and 'Night of Destruction' racing activities. Drivers who participated at Saugus Speedway for those many years were honored, including our very own Ken Sapper. Turns out that Ken was Driver of the Year at Saugus for four years in a row!

Reports from Officers:

Secretary Rex Jaramillo: All OK. Rex gave a report about an upcoming Auto Parts Swap Meet being 'field-tested' in conjunction with the Pasadena City College monthly 'Flea Market'.

Treasurer -- Joan Sapper: Gave a Club finances report, all good.