



Drive Lines

Chapter #40

Our 52nd Year

Visit Our Website

"ValleyV8s.org"

June 23

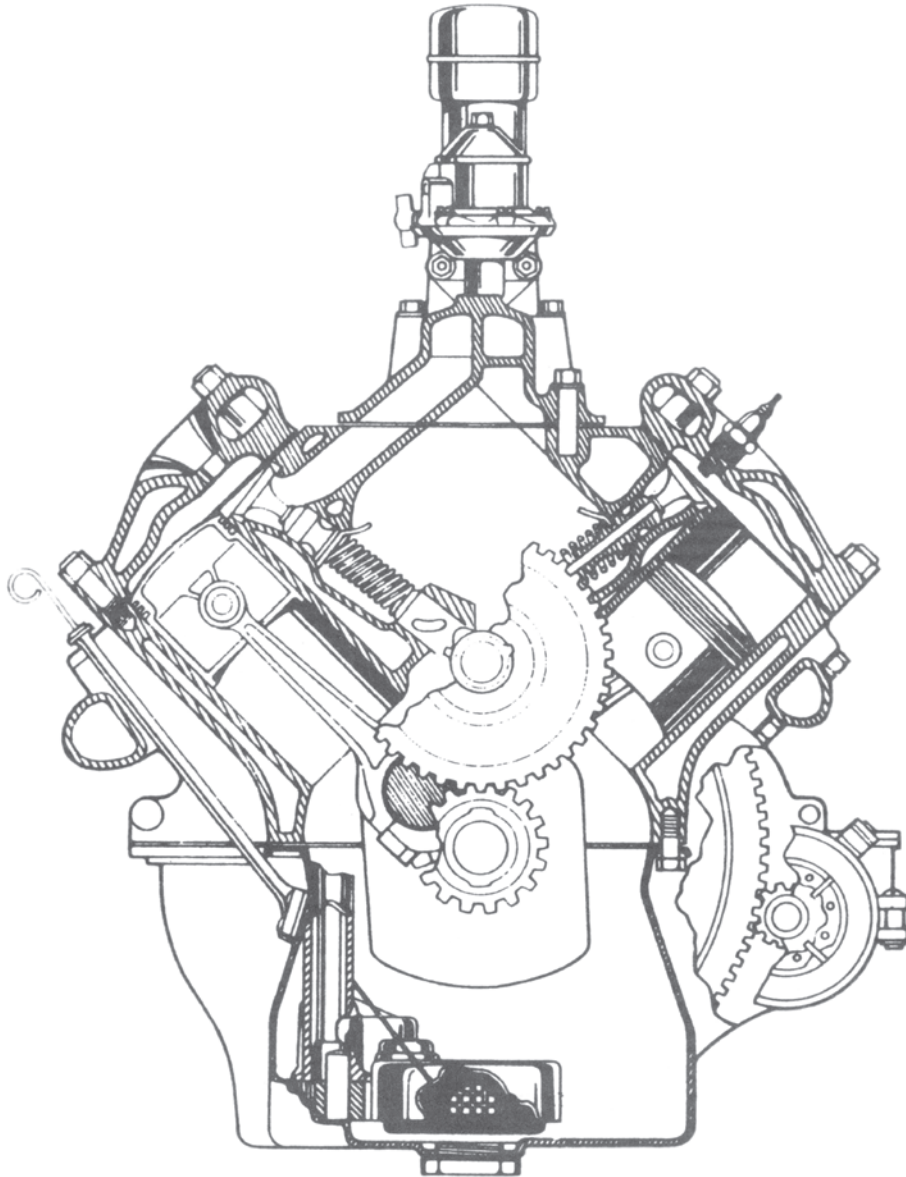

The Valley V8's

9700 Farralone, Chatsworth, Ca. 91311

The Valley V's

2023

President	Jim Ellerbrock	818-437-0412	<i>Past Presidents</i>	
Past Presidents	Ernie Baily	805-433-5540	Jim Rowe	1971
Vice President	Bill Greene	818-606-2874	Doug Peterson	1972
Secretary	LOOKING FOR A VOLUNTEER		Don Durkee	1973-1974
Treasurer	Joan Sapper	818-326-9685	Ed Warnock	1975
Tours	Ernie Baily	805-433-5540	John Busk	1976
Programs	Larry Caplan	818-363-2849	Chip Werstein	1977
	Joe DiFatta	818-700-1939	Stan Misraje	1978
Membership	Howard Brown	818-606-0267	Bill Culp	1979
Drive Lines	Robert Glucksman	818-618-1395	Al Spencer	1980
Prize Raffle	Steve Lehman	818-885-6938	Larry Caplan	1981
50/50	Ken Sapper	818-326-1286	Bob Rose	1982
Ladies / Birthdays / Sunshine	Bobby Searl	818-353-6767	Don Durkee	1983
Name Badge	Karen Lehman	818-885-6938	Paul Kirk	1984
Car of the Month	Members		Kent Lowry	1985
Web Master	Scott Dudrick	818-687-9836	Dave Sanborn	1986
Tech Addv	Jerry Case		John Kemmerer	1987
			Dudley Ochsner	1988
			Jerry Jensen	1989-1990
			Joe DiFatta	1991
			Chuck Shubb	1992-1993
			George Richards	1994
			Jerry Littner	1995
			Dick Smith	1996
			Chuck Mair	1997
			Dennis Keene	1998
			Rose Golt	1999
			Don Stout	2000
			Steve Boskovich	2001-2002
			Joe DiFatta	2003
			Wendi Potter	2004
			Ken Sapper	2005-2006
			Steven Batesole	2007
			Harry Baker	2008-2009
			Dave Bergman	2010
			Randy Watson	2011-2012
			Steve Boskovich	2013-2014
			Stan Miller	2015
			Don Durkee	2015
			Vasken Hagopian	2016-2018
			Ernie Baily	2019-2022
			Jim Ellerbrock	2023 - ????

**For more photos of Club Events,
Please check out Web & Facebook sites**

Visit our Web Site: valley V8s.org

Facebook: **Valley V8s**

(<https://www.facebook.com/groups/579123315803014>)

Drive Lines is Published by

The San Fernando V8's Regional Group 40

of the Early Ford V8 Club of America

9700 Farralone, Chatsworth, Ca. 91311

Madmodelr@aol.com

Meeting: 1st Tuesday of the Month, 6:00p

Lulu's Restaurant and Sports Bar

16900 Roscoe Blvd, Van Nuys, CA 91406

Our Next Meeting
6 June 23

HELLO FELLOW MEMBERS

We would like to know more about You, Your Car...
 So, What I would like from our members is a picture of
 you with your car, with a small story. (1 Paragraph)
 That way, We get to learn more about our members, &
 we can put a face to a name & car
 Please make all submissions to ether
 "Drivelines" at madmodelr@aol.com, or
 "Drivelines" 9700 Farralone Ave. Chatsworth, Ca. 91311

Thank You
 Rob Glucksman, DL Editor

And now for some
 "Pressing" News

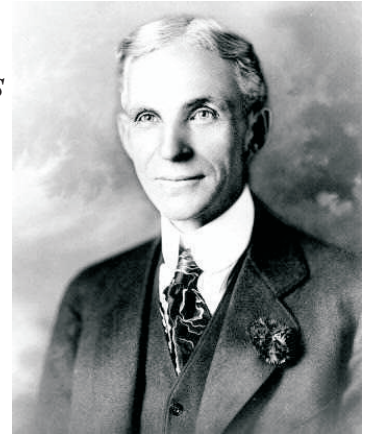

This could be YOU
For ONLY \$5.00 a
month
You can be seen by
every member of the
club, as well as
supporting the club
Such a Deal....
If you can find a
better deal, Still deal
with your club

Woodland Hills Country Club
 Rebecca Bauman
 Director of Private Events
 21150 Dumetz Road
 Woodland Hills, CA 91364
 Tel: (818) 347-1511, ext. 226
 rebecca@woodlandhillscs.org

"Your Ad Here"
 For only \$5.00 a month,
YOU
 can have your
 business card ad
 right here

For more details,
 Please call or Email Rob at
 818-882-2002, / madmodelr@aol.com
 Please put "Drivelines" in the subject
 Please make all payments to
 "Valley V8 Club"

Great Western Container
 SOLUTIONS IN PACKAGING AND GRAPHIC DESIGN

Steve Boskovich

Office (818) 341-2291
 Cell (818) 903-6620
 Fax (818) 341-1050

P.O. Box 4074
 Chatsworth CA 91313

MOONEY INDUSTRIES
 Precision Machining Inc.
 8744 REMMET AVE.
 CANOGA PARK, CA 91304
 (818) 998-0199
 FAX (818) 341-2073
AL MOONEY
 C.F.O.
 al@mooneyindustries.com

SPEEDWAY ENGINEERING



Ken Sapper
 President

ken@1speedway.com
 Office: 818.362.5865
 Cell: 818.326.1286
 Fax: 818.362.5608
 13040 Bradley Avenue
 Sylmar, CA. 91342
 www.1speedway.com

MIKE QUIROGA
 President/CEO
 O: 818.780.8820
 F: 818.780.1713

16046 Blythe St.
 Van Nuys, CA 91406

MIKE'Sth
 ROOFING & BUILDING
 ANNIVERSARY 1972-2012
 MIKE'S GOT YOU COVERED

www.mikesbuilding.com

From The President



Message from

Thanks to all who attended the May 2nd Meeting. A big thank you to Joanie and Ken Sapper for bringing their beautiful 40 Ford.

For the present time, we will be leaving the meeting start time at 7:00 PM. This was the feeling after some discussion last meeting. We will talk about it again before we change back to standard time.

The Secretary and Program Director positions are still open. Thanks to Vice President Bill Greene for taking the minutes for the meeting. As suggested, we will have alternate persons do the minutes until a permanent secretary is assigned. Please keep in mind that our club will not function unless we have active volunteers. The Ventura chapter has already slowed down. The National Club has issued rules on how to dissolve a chapter. Are we on the same path? Unless we have more active volunteers, we will be.

All are encouraged to submit ideas for day trips, guest speakers and articles for the "Driveline".

Howard has informed us that he now has the 2023 Membership Directories. He will be passing them out at the next Meeting

Ernie has been busy organizing our next driving excursions. Our next one will be to the Agua Dolce Winery. We will be meeting next Sunday the 21st at the Knollwood parking lot at 10:00 AM and leaving shortly after. There will be no organized tour at the Winery. Lunch will be at 2:00 at the Route 66 Café. Please reference Ernie's attachment to the E-mail that Howard sent out for exact details. Contact Ernie if you are going (or not) so he can make plans with the restaurant.

If at all possible, please encourage the recruiting of new members. We need new blood. See you next meeting.

Prez Jim Ellerbrock



29 May 23

Memorial Day (originally known as Decoration Day) is a federal holiday in the United States for honoring & mourning the U.S. military personnel who have died ...



14 June 23

In the United States, Flag Day is celebrated On June 14. It commemorates the adoption of the flag of the United States on June 14, 1777, By resolution of the Second Continental Congress

21 June 23



From the Vice President & Secretary Pro Tem



Bill Greene
Vice President 2023

Here are my notes from this months May meeting.

Jim Ellerbrook began with the pledge of allegiance.

Then we were introduced to our guest, Vic Timur, long time member, 1st time attendee.

Treasurer Joanie: No change, just dollars.

Editor Rob: Nothing new. Surprise, Surprise.

Joe Difatta: Car show at Rancho San Antonio Boys Home 05/07/2023.

Blake Wilcox: Montrose car show 07/02/2023.

Ernie expands on Rancho San Antonio Boys Home.

Other show/events: Agua Dulce Wine Tour + Lunch Tentative 05/21/2023

Hollywood Impact Car Show.

Mopars in May-Ontario

Antique Nationals-Ontario

GM Show- Warner Center

Studebaker Show-LaPalma Park

Road Kings-Johnny Carson Park Burbank

Glendale Cruise-07/15/2023 (I like to call it the Touchy/Feely show)

Karen Leiman suggestion of a car show at the Northridge Womens Club. Taken under advisement

Jerry Littner indicated that the Nationals meeting is postponed.

CAR of the MONTH: Ken and Joanie Sapper's beautifully restored 1940 Deluxe 2Dr Sedan.

Bill Greene's 1956 Ford Wagon is finally painted after 15 years. Congratuation (A 55 Ford would be better)

Ernie talked about his 1956 Packard, his old Studebaker and his 1958 President Hardtop

Ken Sapper talked about the Fords Forever Car Show at Irwindale.

Name badge winner-Jerry Littner

50/50 Raffle winner- Chris Haynes

Raffle Prize winners Tonty Goff (2), Gerald Buck(2), Joe DiFatta (4), Harry Baker(2), Vic Timur(4), Blake Wilcox(2), Madmodlr(1), Howard Brown(2), Harvey Jacobs(2), Ernie Baily(1), Al Mooney(2), Jim Ellerbrook and Joanie Sapper each(1).

And that's all the news that's fit to print from our May meeting.

By the way, we will be picking a roving secretary every meeting, so bring your pad and pen.

Car of the Month

Kenny & Joanie Sapper's 40 Ford 2D sedan

This story is about Frank Deiny's Ford. I am very proud to be the car's caretaker. Over the years I have learned a lot about these wonderful Fords. This '40 Ford DeLuxe Tudor was the Grand Prize raffle car of the Western Regional meet that took place in San Diego, September 20-22, 1974. I don't know where it was originally purchased.

The car needed a little work before it was ready for the big raffle according to our own Ralph Hubbard. So, Ralph Hubbard and Jay Harris delivered it to Jack Miles to make sure it was safe and in running condition. Tickets for the raffle were on sale for at least a year. The car even made the cover of the March/April 1974 V8 Times. The November/December 1974 issue had the meet results.

I found that both Gordie Chamberlin's and Harold Selsen's cars were awarded Dearborn awards there. (From reading articles in the 1974 V8 Times I discovered our own Gordie Chamberlin was named "Best Dressed Man" in his 1940's Zoot Suit (see photo).

As expected, the Grand Prize was the highlight of the Awards Banquet that week! A hush fell over the crowd as the ticket was picked out of the ticket drum. Amazingly the ticket was owned by a 10-year-old girl named Kim Myeroft of Temple City! Kim, her sister, and her father had purchased 3 tickets in February that year. So, the car stayed in the family until Kim was off to college and needed funds for school. The car was sold to a man in the Los Feliz area. He enjoyed owning it for a while, then wanted to sell it.

Frank Deiny saw a picture of it at a Pomona Swap meet in the mid-1980's. Frank made a deal with the owner there and became the new owner. Frank took the car to his shop. Frank did a little work to get it running again but wanted to restore it to Concours condition. Thru the Valley V8's Frank met Jack Miles. Jack agreed to help Frank restore it. As an employee of Frank's, I became involved when Frank became ill with cancer. I worked alongside Jack to finish the car.

These V8 members played a major role in restoring this car: Jack Miles, Jerry Jensen, Larry Caplan, and George Grey. Jack took this car to the Western Regional meet in 1989 held at Lake Arrowhead and was awarded its first Dearborn. The car was driven regularly between 1989-2012. I heard of the Western Regional Meet to be held in Thousand Oaks, hosted by our own Valley V8 Club and the Ventura Club. I worked hard to get it correct and clean. It was awarded its 2nd Dearborn award!

In 2016 I had an opportunity to trailer the car to the Eastern Meet held in Charlotte, NC. I learned much more about correctness. It was awarded its 3rd Dearborn! After this we entered it in the 2018 Western meet held in Bakersfield with all the updates. It was awarded its 4th Dearborn!

Since COVID it hasn't been seen very much. Small shows and our own great tours with our great Valley V8 Club! Thank you, Rob, for including this story about this beautiful Ford!

Kenny & Joanie Sapper



Motor Company in 1932 and was instrumental in



Gordie Chamberlin was the grandest best dressed man in a Parker...
...and a handsome young man with tremendous shoulders. Gordie and the beautiful Phyllis celebrated their 15th anniversary on the evening.

