



Drive Lines

Chapter #40

July 2018

Our 47th Year

Visit Our Websites

"valleyV8s.org"

"Facebook: Valleyv8s"

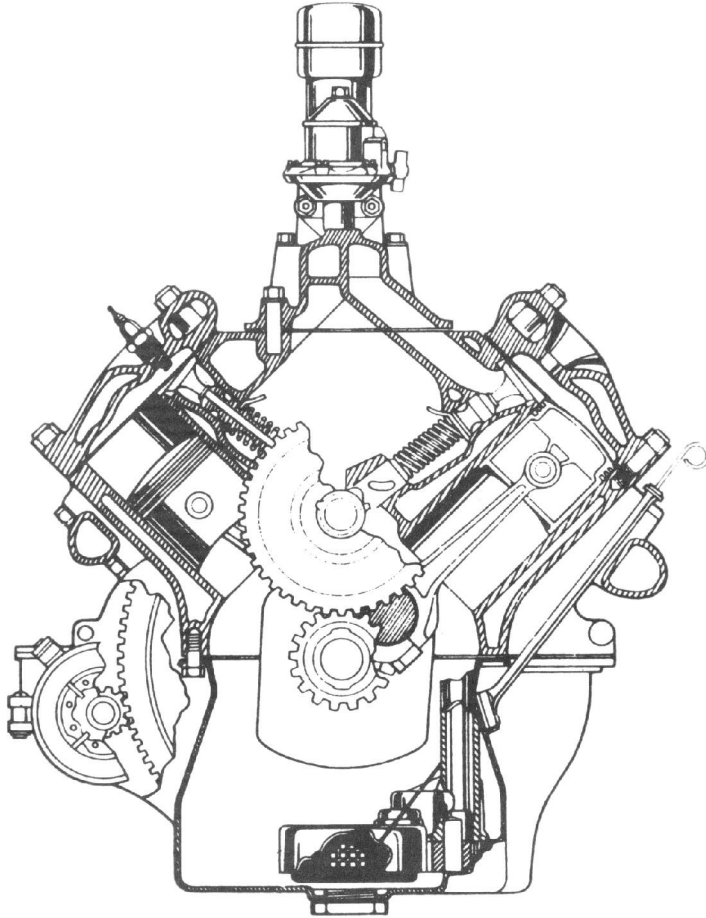

**The Valley V8's
9700 Farralone, Chatsworth, Ca. 91311**

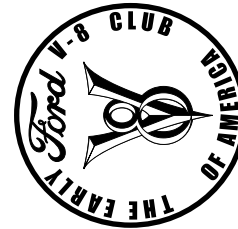

The Valley V's

2018

President	Vaskin Hagopian	323-661-2044
Past Presidents	Don Durkee	
	Stan Miller	818-360-4812
Vice President	Steve Lehman	818-885-6938
Secretary	Rex Jaramillo	213-706-3854
Treasurer	Joan Sapper	818-249-5686
Tours	Kenney Sapper	818-249-5686
	Rich Carter	708-567-2393
Programs	Larry Caplan	818-363-2849
	Joe DiFatta	818-700-1939
Membership	Harry Baker	818-632-9017
	Joan Sapper	818-249-5686
Drive Lines	Robert Glucksman	818-618-1395
	Jim Kelley	310-795-0704
Prize Raffle	Steve Boskovich	818-341-6876
50/50	Ken Sapper	818-380-5686
Ladies / Birthdays / Sunshine	Bobby Searl	818-353-6767
Name Badge	Karen Lehman	818-885-6938
Car of the Month	Jerry Jensen	805-491-3355
Web Master	Scott Dudrick	818-687-9836
Tech. Advisor	John Wolf	818-789-6201

Meeting: 1st Tuesday of the Month, 7:00p
 No host Dinner, Starting at 6:00p
 Rosie's BBQ & Grill, 8930 Corbin Ave.
 Northridge, Ca. 91324

Visit our Web Site: valleyv8s.org

Facebook: **Valleyv8s**

(<https://www.facebook.com/groups/579123315803014>)

Drive Lines is Published by

The San Fernando V8's Regional Group 40
 of the Early Ford V8 Club of America
 9700 Farralone, Chatsworth, Ca. 91311

The Valley V's

Past Presidents

Jim Rowe	1971
Doug Peterson	1972
Don Durkee	1973-1974
Ed Warnock	1975
John Busk	1976
Chip Werstein	1977
Stan Misraje	1978
Bill Culp	1979
Al Spencer	1980
Larry Caplan	1981
Bob Rose	1982
Don Durkee	1983
Paul Kirk	1984
Kent Lowry	1985
Dave Sanborn	1986
John Kemmerer	1987
Dudley Ochsner	1988
Jerry Jensen	1989-1990
Joe DiFatta	1991
Chuck Shubb	1992-1993
George Richards	1994
Jerry Littner	1995
Dick Smith	1996
Chuck Mair	1997
Dennie Keene	1998
Rose Golt	1999
Don Stout	2000
Steve Boskovich	2001-2002
Joe DiFatta	2003
Wendi Potter	2004
Ken Sapper	2005-2006
Stever Batesole	2007
Harry Baker	2008-2009
Dave Bergman	2010
Randy Watson	2011-2012
Steve Boskovich	2013-2014
Stan Miller	2015
Don Durkee	2015
Vasken Hagopian	2016-2018

"Your Ad Here"
For only \$5.00 a month,
YOU

can have your
business card ad
right here

For more details,
Please call or Email Rob at
818-882-2002, / madmodelr@aol.com
Please put "Drivelines" in the subject
Please make all payments to
"Valley V8 Club"



CPR TRAINING

Get trained. Save a life. You'll be glad you did.

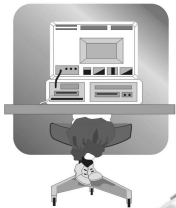

R.H.FACTOR GRAPHICS
*Computer Graphics
Desktop Publishing*



For all your Pre-Press needs

Robert Glucksman
Chatsworth, Ca. 91311
Office: **818-882-2002**
Cell: **818-618-1395**
madmodelr@aol.com

Hello Fellow Members...
We would like to know more about
You, Your Car...

So, What I would like from our
members is a picture of you with your
car, with a small story. (1 Paragraph)
That way, We get to learn more about
our members, & we can put a face to
a name & car

Please make all submissions to ether
"Drivelines" at madmodelr@aol.com, or
"Drivelines" 9700 Farralone Ave.
Chatsworth, Ca. 91311

Thank You

Rob Glucksman, DL Editor

4TH OF JULY

"We Fix 'Em"

THE RADIATOR WORKS

Auto Cooling System Services

(818) 701-0504

(818) 701-0536

18255 1/2 Parthenia St.

Northridge, CA 91325

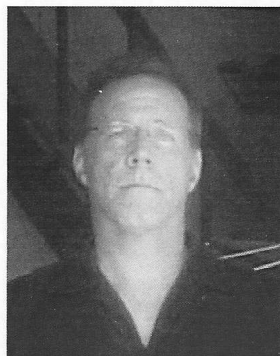

ARBONNE.
INDEPENDENT
CONSULTANT

Steven Lehman
Arbonne Independent Consultant
Consultant
23592171

Reset, Restore, Rebalance
Discover Ultimate Health,
C 818.517.1268

ArbonneForever@yahoo.com
www.stevenlehman.arbonne.com

**SPEEDWAY
ENGINEERING**



Ken Sapper
President

ken@1speedway.com
Office: 818.362.5865
Cell: 818.326.1286
Fax: 818.362.5608
13040 Bradley Avenue
Sylmar, CA. 91342
www.1speedway.com

Car of the Month: Our newest members Oliver Calibet and Sandrine Cutright, won top honors for Car of the Month with their 1953 Ford convertible. Did you see it out there, it looked beautiful with the setting sun as a backdrop. They actually purchased the car from Club members. Bill Samtag and Judy Zabaglo. It's very original, has the venerable 239 cubic inch 8BA engine, the last year of the Ford flathead V-8 in the U.S. After 1953, flathead V-8 engine production continued in Europe where the engine was used in French military vehicles clear up into the 1990's! You may have heard of the flathead 'French' block. Anyway, Sandrine and Oliver's convertible is amazingly preserved. It's equipped with power steering, makes it easy to wheel around. In the interest of safety, it's been retrofitted with a GM-style dual circuit/dual diaphragm power brake system. And it's got a 3-speed with overdrive. So it came from the factory with some nice low 4.10 gears out back, so it has plenty of snap off the line while the overdrive allows the sweet little mill to loaf at freeway speeds. Very nice ride, Sandrine and Oliver, nicely preserved V-8 you have, thanks for joining our ranks and thanks for being owners and caretakers of such a nice Ford!



From the Editor

Pismo Beach Classic, June 1,2,&3, 2018

My Beautiful Wife, Sharon, Took Me for 3 awesome days of Beach, Chowder, & oh yeah CARS

The first nite, the Rides start coming into town. Then, around dusk the Parade of cars start a cruise thru town.

Day 2, The cars all have assigned spots... Good thing, to My understanding, there were about 1500 cars.

Very laid back atmosphere, Nothing too over the top, Just a great time...

Well, I did miss MY car...



*And now for some
"Pressing" News*

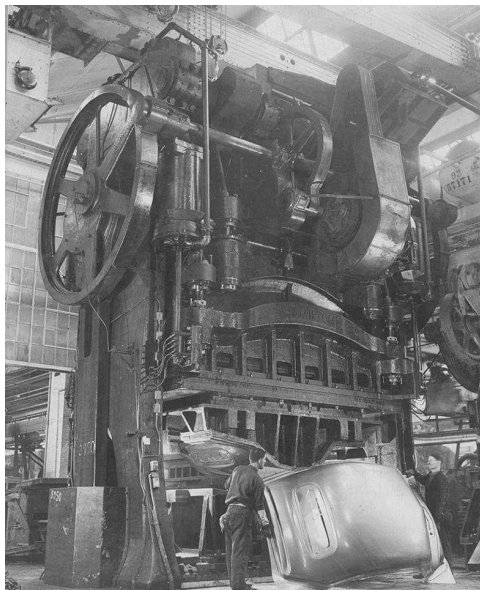

An old woman was sitting on the porch with her husband, sipping a glass of wine. "I love you so much," she says. "In fact, I doubt I could live without you. I know I don't want to even try to get thru a single day without you." Her husband is almost speechless. "Is that you talking, or the wine?" he asks.

"It's me," she replies. "Talking to the wine."

Remember....

The JULY meeting will be on the 10th of July

Visit our Web Site: valleyv8s.org

Facebook: **Valleyv8s**

(<https://www.facebook.com/groups/579123315803014>)

FLAG FLYING GUIDE

— DISPLAYING THE AMERICAN FLAG —



ON A POLE WITH ANOTHER FLAG
The U.S. flag is always be at the top of the pole

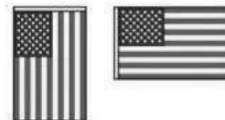

AGAINST A WALL OR IN A WINDOW
The blue field should be to the observer's left

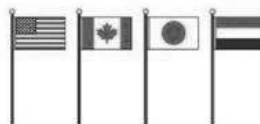

WITH THE FLAGS OF OTHER NATIONS
All same size and displayed at the same height

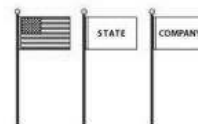

FROM A STAFF ADJACENT TO OTHERS
U.S. flag should be placed at the extreme left

— THE AMERICAN FLAG AT HALF-STAFF —

The center point of the U.S. flag should be aligned with the center point of the flagpole.

When a flag is flown at half-staff, it should be raised to the peak for an instant, then lowered to half-staff.

Unless otherwise noted, the flag should be half-staff from sunrise to sunset

HALF-STAFF ON THESE DAYS:

Peace Officers Memorial Day, May 15th

Memorial Day, last Monday in May (sunrise until NOON)

Patriot Day, September 11

Korean War Veterans Armistice Day

National Firefighters Memorial Day

Pearl Harbor Remembrance Day, December 7th

As well as any day ordered by the President of The United States or by the Governor of your state.

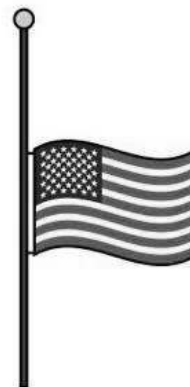



Chapter 40 – San Fernando Valley V-8's Club

Monthly Meeting Minutes for Tuesday June 5, 2018



7:05 pm: Meeting called to order

President Vasken Hagopian welcomed the group to the June Meeting, then led us in the Pledge of Allegiance.

Guest Introductions, other comments: Welcome back! Vasken welcomed our newest members back, Oliver Calibet and Sandrine Cutright, who brought their beautiful 1953 Ford convertible. Thank you, veterans! Vasken acknowledged the veterans in the meeting as a follow-up to Memorial Day. Program presenters: Vasken called Robert Glucksman up to the front to introduce our guests and presenters for the evening program: His wife Sharon and one of her co-workers Sylvia Duncan.

Program: CPR: It's a life-saver!

Our program for the evening was one we have been looking forward to: An informational session and demonstration of CPR. Now CPR is an 'acronym' or abbreviation for Cardiopulmonary Resuscitation. Simply put, it's knowledge about saving a life. Interestingly, the day of our Tuesday meeting was National Hands-on CPR Day, great timing! **Choking:** The session started with a discussion of airways and choking. **The universal sign for choking** is hands clutched to the throat. More deaths from choking occur in restaurants than any other place, mostly in the restrooms. People are eating, they start to choke, get embarrassed, go to the restroom, where very often they choke and die. So an awareness of those around us is important. If a person is choking on a piece of food, it's important to dislodge it from their airway as quickly as possible. **The Heimlich maneuver** will do this, and it's pretty straightforward: Position yourself behind the person who is choking, put one of your legs in front, the other leg behind them (in case they faint), wrap your arms around them below their ribcage, clasp your hands and pull as hard as you can. In most cases the food or obstruction will be dislodged quickly. And if the person is already unconscious, in some cases, better yet. The 'esophagus' or airway, will be relaxed, making it easier to dislodge the object from the airway. For unconscious, the challenge may be positioning the person for the Heimlich maneuver, usually behind them. **If you're alone and start choking**, you can do the Heimlich on yourself. Grab your hands together and pull up hard on your lower abdomen. Of course it's better to have someone else do it, but in a pinch it's certainly worth a try. **CPR for adults:** First yell for help. Have someone phone 911. Look for either no breathing or only gasping. Then center both hands on the chest, and push hard and fast: Do this 30 times. Then tilt the head back, make sure the tongue is out (to open the airways) and give two deep breaths into their mouth. Yep, even if it's a stranger. Repeat this CPR process until medical help arrives: 30 compressions and 2 breaths, 30 compressions and 2 breaths. **CPR for children:** Same as adults, except not so deep and hard. Sylvia mentioned that compressions to the chest can save a life even if someone has an object caught in their throat. She then gave us a demo of the CPR process on a mannequin. Afterwards she called for volunteers to try it, we had a few brave V-8 souls give it a try, and they did pretty well. **Heart attacks: Questions:** Who has more heart attacks, men or women? Men under 50 win. Over 50, the numbers are pretty equal between men and women. Can you have a heart attack at 40? Yes. Sadly, younger victims don't do so well, they have more violent heart attacks. The quicker to the hospital, the better chances of survival. **Heart attack 'classic' symptoms:** These may include uncomfortable chest pressure, fullness, squeezing or pain in the center of the chest, pain that spreads to the shoulders, neck, or arms. Women may experience the same classic symptoms but they are often milder. Some may think it's heartburn. Refer to the handout that our presenters gave us for more information on heart attack symptoms. **Stroke:** Time is critical when a stroke occurs, remember the '3-hour rule'. There's a greater chance of recovery if you act quickly. Getting help fast could reduce disability and death. **Stroke symptoms** may include slurring, paralysis or weakness, the person can't stick their tongue out, the face may have a droopy look. **In summary**, for any medical issue pertaining to the above points, call 911, don't drive to the ER. Our presenters then mentioned Youtube for more specific demo's and as a good review about what we covered this evening. **Finally, please review** the Handout that was distributed. Thanks, ladies for a very informative presentation, we really appreciate it.

7:45 pm: Break called 8:05: Meeting resumed

(Monthly Meeting Minutes Continued)

Opening comments by our President: Our Program, a most excellent presentation about CPR, was moved to the front of the meeting. So at this time, President Vasken made his 'opening comments'. 1) Happy Father's Day! Fathers Day, 2018 is Sunday June 17. 2) Flag Day, 2018: Flag day, 2018, falls on June 14 this year. Thank God for our country, our freedoms, and 'Old Glory!' 3) Swell rides out there! Vasken said that it was good to see all of those 'nice old cars out there' in the parking lot this evening. All members who drove their old Fords and other makes, thumbs up, it was a good showing! 4) Vacation! Vasken talked about his vacation to Cancun with his wife, shared about some of his adventures including dealing with the local police during a few incidents, never a dull moment! 5) Next meeting: Tuesday July 10, to avoid conflicts with July 4th activities.

Reports from Officers:

Secretary – Rex Jaramillo: Everything OK.

Treasurer -- Joan Sapper: Everything OK. Joan gave a Club financial report.

Tours: Ken Sapper: LA Roadster Show: This year a change: The Show is scheduled for Friday and Saturday June 15 and 16, leaving Father's Day Sunday open for celebration of Father's. California Oil Museum Tour is still being finalized, will likely happen in September.

More Car Events: Vasken then shared information about other old car-related activities: July 1: Montrose Car Show. July 8: Long Beach High Performance' Swap Meet. July 21: Glendale Brand Blvd. Cruise Night. July 22: Wounded Warriors Car Show, Redondo Beach. July 28: Woodies at the Beach Santa Barbara City College.

Drive Lines Editor – Robert Glucksman: Reminded us that Club member and Webmaster Scott Doudrick has placed our Car Club on Facebook. He also acknowledged our two new Club members Oliver and Sandrine for bringing their beautiful '53 Ford convertible.

Membership/Directory – Harry Baker hands over the reins for this position to Jerry Littner.

Car of the Month: Our newest members Oliver Calibet and Sandrine Cutright, won top honors for Car of the Month with their 1953 Ford convertible.

Ladies raffle: Handled by Bobbie Searl. Nice plant arrangements were won by Joan Sapper and Sharon Kopito-Glucksman

Birthdays for June: Bobbie Searl recognized the following overjoyed individuals: June 1 – Chuck Schneider June 2 – Dick Camolin, Dick Colarossi June 3 – Vasken Hagopian, Jerry Jensen June 6 – Ralph Hubbard, Don Stout June 7 – Larry Caplan, Rex Jaramillo June 9 John Kemmerer June 18 – Judy Case, Diane Lohr June 21 Jennifer Cuozzo June 26 Diania M. Horsford June 28 – Scott Doudrick

Name Badge: Handled by Karen Lehman, won by President Vasken.

50/50 Drawing: Handled by Ken Sapper, won by President Vasken, no misprint, see above. (Hmm, not fixed, we don't think)

Raffle: Handled by Steve Boskovich. As always, many winners took home some nice prizes. Thanks, Steve for handling the Raffle. Also, Steve mentioned that his brother George, a well-known collector of Ford high-performance cars, was able to purchase another of the last two Cobra's that Carroll Shelby built, what a score, how amazing is that!

Vasken: Reminded us of the next Club meeting date, July 10. Invite your friends, and drive home safely.

9:00 pm: Meeting adjourned.

Minutes submitted by Rex Jaramillo



From the President

Happy 4th of July.

June meeting was extraordinary, because of all the beautiful classic Fords that the our members drove in with.

Let's do this in July-November, show your car to the members, let us enjoy our classic cars, after all we worked very hard to maintain and keep them.

C.P.R. Thank you Sharon for setting up this hands on demonstration.

Sylvia gave us a great demonstration on the, mannequins, and answered many of our questions. We do not know 100%, but when an emergency arises, you will be proud that you saved a life, a brother, or sister, or a friend.

I told Evelyn that Sylvia said in an emergency I can rip the clothes off a woman, and get my hands in there!!!!

Evelyn said suuuuuuuure!!!!

Thank you again Sharon and Sylvia.

A quiet car show that is growing rapidly in Pasadena, in the parking lot of Lake Ave. Church. Great hamburgers, hot dogs, etc. all for donation only.

You can also join for a 15 minute prayer with the minster, the minister is a down to earth guy, looks like a car guy with a t shirt.

Fathers Day , all the Home Depot, Lowe's, and other hardware stores, offering the latest screw drivers, work shoes, boots, gloves, etc. for men.

On Mothers Day, all the department stores were advertising diamonds, jewelry, shoes, latest fashion clothing, etc. (no screw drivers).

Sunday July 29th is the old Fashion day at the park in Marina Del Rey.

Classic yachts, vintage automobiles, with Gerard and Pamela Buck.

Let us all participate as the Valley V8 Car Club. It is fun, different, and you will enjoy it.

Please bring a friend to our meeting.



Happy 4th of July.

Vasken Hagopian

