

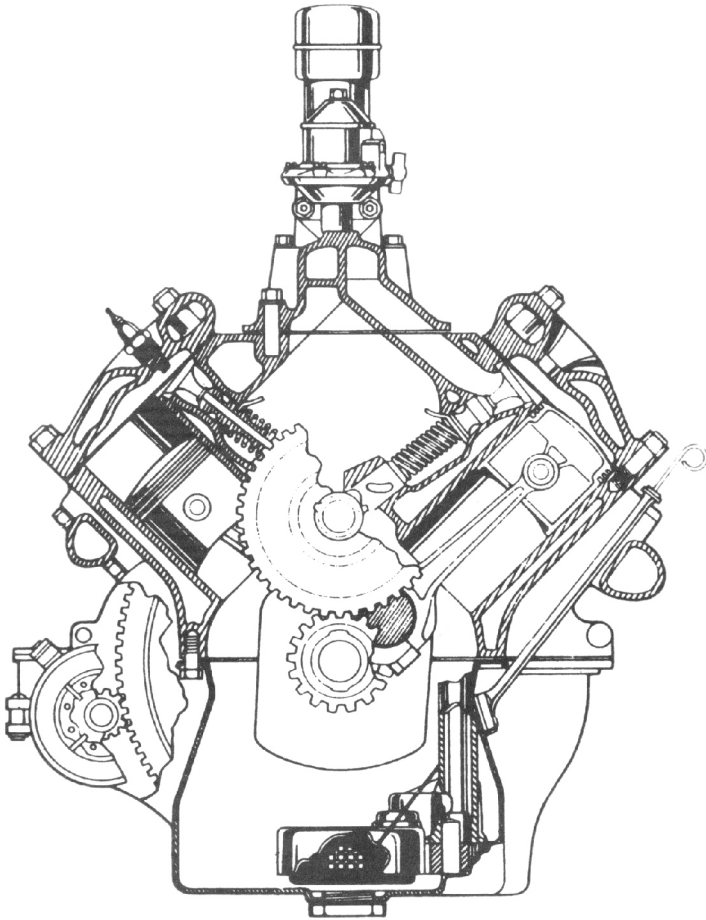

Drive Lines

Chapter #40
Our 48th Year
Visit Our Website
"valleyV8s.org"

July 2019



The Valley V8's
9700 Farralone, Chatsworth, Ca. 91311

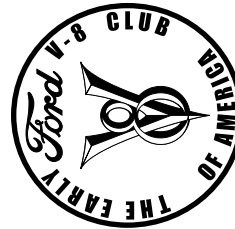

The Valley V's

2019

President	Ernie Baily	805-428-0558
Past Presidents	Vaskin Hagopian	323-661-2044
Vice President	Jim Ellerbrock	818-437-0412
Secretary	Rex Jaramillo	213-706-3854
Treasurer	Joan Sapper	818-249-5686
Tours	Kenney Sapper	818-249-5686
	RichCarter	708-567-2393
Programs	Larry Caplan	818-363-2849
	Joe DiFatta	818-700-1939
Membership	Sandrine Cutright	310-804-7790
	Oliver Calibet	818-310-8571
	Joan Sapper	818-249-5686
Drive Lines	Robert Glucksman	818-618-1395
Prize Raffle	Steve Boskovich	818-341-6876
50/50	Ken Sapper	818-380-5686
Ladies / Birthdays / Sunshine	Bobby Searl	818-353-6767
Name Badge	Karen Lehman	818-885-6938
Car of the Month	Jim Ellerbrock	818-437-0412
Web Master	Scott Dudrick	818-687-9836
Tech. Advisor	John Wolf	818-789-6201

Meeting: 1st Tuesday of the Month, 7:00p
 No host Dinner, Starting at 6:00p
 Rosie's BBQ & Grill, 8930 Corbin Ave.
 Northridge, Ca. 91324

Visit our Web Site: valleyv8s.org

Facebook: **Valleyv8s**

(<https://www.facebook.com/groups/579123315803014>)

Drive Lines is Published by

The San Fernando V8's Regional Group 40
 of the Early Ford V8 Club of America
 9700 Farralone, Chatsworth, Ca. 91311

The Valley V's

Past Presidents

Jim Rowe	1971
Doug Peterson	1972
Don Durkee	1973-1974
Ed Warnock	1975
John Busk	1976
Chip Werstein	1977
Stan Misraje	1978
Bill Culp	1979
Al Spencer	1980
Larry Caplan	1981
Bob Rose	1982
Don Durkee	1983
Paul Kirk	1984
Kent Lowry	1985
Dave Sanborn	1986
John Kemmerer	1987
Dudley Ochsner	1988
Jerry Jensen	1989-1990
Joe DiFatta	1991
Chuck Shubb	1992-1993
George Richards	1994
Jerry Littner	1995
Dick Smith	1996
Chuck Mair	1997
Dennis Keene	1998
Rose Golt	1999
Don Stout	2000
Steve Boskovich	2001-2002
Joe DiFatta	2003
Wendi Potter	2004
Ken Sapper	2005-2006
Steven Batesole	2007
Harry Baker	2008-2009
Dave Bergman	2010
Randy Watson	2011-2012
Steve Boskovich	2013-2014
Stan Miller	2015
Don Durkee	2015
Vasken Hagopian	2016-2018
Ernie Baily	2019-????

"Your Ad Here"
For only \$5.00 a month,
YOU

can have your
business card ad
right here

For more details,
Please call or Email Rob at
818-882-2002, / madmodelr@aol.com
Please put "Drivelines" in the subject
Please make all payments to
"Valley V8 Club"



HELLO FELLOW MEMBERS

We would like to know more about You,
Your Car...

So, What I would like from our members is
a picture of you with your car, with a small
story. (1 Paragraph)

That way, We get to learn more about our
members, & we can put a face to a name &
car

Please make all submissions to ether
"Drivelines" at madmodelr@aol.com, or
"Drivelines" 9700 Farralone Ave.

Chatsworth, Ca. 91311

Thank You

Rob Glucksman, DL Editor

Our Next Meeting
Tues, 2 July 19

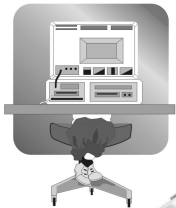

R.H.FACTOR GRAPHICS
*Computer Graphics
Desktop Publishing*



For all your Pre-Press needs

Robert Glucksman
Chatsworth, Ca. 91311
Office: 818-882-2002
Cell: 818-618-1395
madmodelr@aol.com

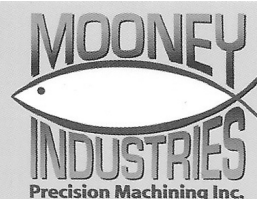

8744 REMMET AVE.
CANOGA PARK, CA 91304
(818) 998-0199
FAX (818) 341-2073

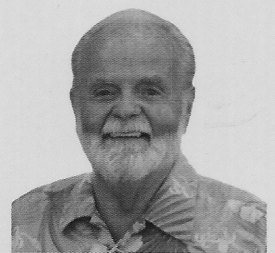

AL MOONEY
C.F.O.

al@mooneyindustries.com

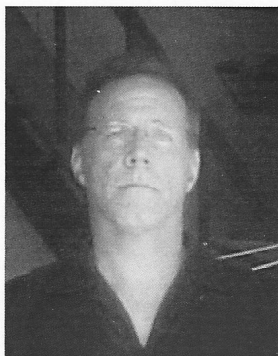

ARBONNE.
INDEPENDENT
CONSULTANT

Steven Lehman
Arbonne Independent Consultant
Consultant
23592171

Reset, Restore, Rebalance
Discover Ultimate Health,
C 818.517.1268

ArbonneForever@yahoo.com
www.stevenlehman.arbonne.com

**SPEEDWAY
ENGINEERING**



Ken Sapper
President

ken@1speedway.com
Office: 818.362.5865
Cell: 818.326.1286
Fax: 818.362.5608
13040 Bradley Avenue
Sylmar, CA. 91342
www.1speedway.com

CAR OF THE MONTH

Let Me start this month's "COTM", with a THANK YOU to Mr. Jerry Jensen.
Jerry has stepped down from choosing the "COTM" after many years of service
Mr. Jim Ellerbrock & Myself, will be handling the duties
We do ask that if your ride is chosen, for you to write a short story about your ride.

Thank You
Rob, DLE

This months "Car of the Month" honors go to David & Lynn Dwyhalo & their beautiful 35 Ford 5w coupe
Congrats...Ride Well...



NOT a COTM, But defiantly a "Cool Dude"... Our own Jim Kelley
Mr. Jim is the proud owner of a Pantera, & this is no trailer queen, it's a driver. He
drove it to the June meeting
Jim, I tip My hat to you, your awesome
Ride Well My Friend



Program / Speaker

Ernie introduced our guest speaker, Larry Kaplan. The subject: *What's the latest trend with old car pricing?*
Ralph Hubbard, a member of our Club, wrote an excellent paper on this topic. Unfortunately Ralph couldn't
join us, so Larry did a great job of presenting Ralph's paper. Ralph prefaced that most of his remarks are his
personal opinion. However he's highly qualified to share them. For starters, old cars have been and will likely
always be in demand. It just depends on the vehicle as far as values go. An interesting trend is in place: It
seems that early to mid 50's cars are starting to be in higher demand. Reason: They have features that make
them easier to drive. Power steering, power brakes, automatic transmissions, even air conditioning make them
more appealing for the masses. Some cars that are going down in value are '39 Fords, coupes, convertibles,
wagons, etc. Ralph feels that the 1940 Fords have passed them up. Trucks are still strong in sales. The big auto
auctions support this fact. Street rods, hot rods built with aftermarket replacement bodies, both steel and
fiberglass, have gone down in value. Complete finished cars sell more quickly and for much better prices than
'project cars'. Ralph also mentioned that it's a good idea to use an inventory system, starting where the car(s)
are stored, service history records, DMV records, registrations and titles, insurance information, and purchase
dates. Organized files makes it much easier when we need to sell our cars. Look ahead, be organized, have a
folder on each car, make sure the seller you have in mind knows the car. In summary, our old Fords will still be
worth hanging on to, some more, some less. However that all fades away when we're in our Fords cruising,
doesn't it?

PROGRAM HEADLINE.... Fireworks at our July 2nd Meeting!!!!

We all know that July 4th is an evening of "Fireworks" to celebrate our nation freedom, soooo, why not fireworks at our
July 2nd meeting. AND the person to do that will be our immediate Past Pres. Vaskin Hagopian.

Vaskin will enlighten us about his adventures with him and Evelyn Traveling...enjoying their autos and perhaps a
story how he purchased his 34 Ford!!! See you on the 2nd of July

JoeD

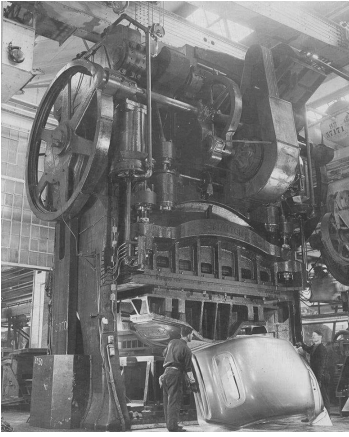

And now for some
"Pressing" News



MCTC
MILLER
Career and Transition Center
8218 Vanalden Avenue
Reseda, California 91335

NEW MEMBER

Mr. Jay Russell,
Our newest member, has
a nice '35 Ford Cabriolet
that's being shipped from
the east coast.

Welcome



FROM THE EDITORS DESK

I would like to extend Best Wishes, & Get Well to
Stan Miller, who is recovering from a very serious health issue
Chuck Shubb, Who is recovering from a fall
Nancy Wardel, Who is recovering from Hip replacement

CHAPTER 40 -- SAN FERNANDO VALLEY V-8'S CLUB MONTHLY MEETING MINUTES FOR *Continued*

A few other events: There are many events, too numerous to mention, drop by the table to the right of the podium for car show fliers. Also refer to SoCalCarCulture.com for more information on car-related activities.

Upcoming Isky tour: Vasken Hagopian then pitched the Isky Shop tour. He mentioned that our V-8 Club is the only club that Ed Iskenderian belongs to. Our club tour through Isky's shop is a first, no clubs etc. are allowed in the 'back' because of machinery, hazardous conditions, etc. Vasken mentioned a few more car shows, never a shortage.

Kudos to Vasken! Vasken mentioned an article that was shown in the February V-8 National magazine. On page 9, Vasken identified a carburetor base fitting, way to go Vasken!

Reports from Officers:

Secretary Rex Jaramillo: All OK.

Treasurer -- Joan Sapper: Gave a Club finances report, all good.

Tours -- Ken Sapper: Reported on the Gilmore Car Show held at Farmer's Market in Los Angeles. Great show, wonderful barbecue dinner, very well-run show, proceeds benefit the Gilmore Foundation. Father's Day Car Show at Pomona: Held Saturday and Sunday June 15 and 16, it's gone back to management by the L.A. Roadsters Club. There was a great swap meet both days and a barbecue dinner on Saturday night. Very well run event. Upcoming Iskenderian shop tour is scheduled for Saturday June 29.

Drive Lines Editors Rob Glucksman: All good.

Membership/Directory All good.

7:25 pm: Break called 7:50 pm: Meeting resumed

Ladies raffle: Handled by Bobbie Searle. Beautiful plants were won by Reenie Jaramillo.

Birthdays for June: Handled by Bobby Searle: The following were recognized: Chuck Scheider 1, Dick Camolin, Dick Colarossi 2, Vaskin, Hagopian 3, Ralph Hubbard, Don Stout 6, Larry Caplan, Rex Jaramillo 7, John Kemmerer 9, Judy Case, Diana Lohr 18, Jennifer Cuzzo 21, Diania M. Horsford 26, Scott Doudrick 28.

Name Badge: Handled by Reenie Jaramillo, won by Jim Ellerbrock.

50/50 Drawing: Handled by Ken Sapper, won by Don Stout.

Program: Ernie introduced our guest speaker, Larry Kaplan. The subject: *What's the latest trend with old car pricing?* Ralph Hubbard, a member of our Club, Unfortunately couldn't join us, so Larry did a great job of presenting

Raffle: Handled by Joe DiFatta: Many nice gifts were taken home tonight, thanks Joe for handling our Raffle.

8:30 pm: Meeting adjourned.

From The President

Hello again fellow V8ers,

I hope all of you had a great Fathers Day! My brother and I always go to a Car Show to Remember our father, since he was the one that got us interested in cars and auto racing, as you know so many car shows to chose from on the Fathers Day weekend . We decided on the Fathers Day car show out in Oxnard, its a nice show on the grass at Channel Island park. We happened to meet up with Scotty Cramolini displaying his 1953 Ford Ranch Wagon at the Channel Island Museum with a special section in front of the muesum just for the Santa Barbara Woodie Club. He and their President offer a invite to us to join them on a event on July 27th at the Santa Barbara College. It sounds like it might be a nice event! Even cooler if the hot weather comes on! Also, We have our tour to Ed Iskenderians shop coming up. From what I hear we will have a fair sized group for the tour. I'm also hoping that you all will join us on our July 26th tour to the Santa Susana Depot museum. It should be fun and informative!

I mentioned at the meeting I've been trying to get my younger brothers 1956 Studebaker Golden Hawk fired up after sitting for 20 plus years. Each time I get close I find some other thing to fix with out speeding any money. Thats kind of hard to Do! However I did get it running with the help of our new member Howard Brown who just happens to be the President of the local Studebaker Club. So know some fine tuning and trying to get it to move!

Our VP is also working on a possible "Gathering" type car show event at the Valley Relics Museum. More to follow on that! As a added note I've been contacted by the Model T club in regard to doing some kind of joint event in the future. Our board members are actively trying to presue future events/tours.

Looking forward to seeing you all at the July meeting on July 2nd. Remember "Drive your V8's"

Prez Ernie

CHAPTER 40 -- SAN FERNANDO VALLEY V-8'S CLUB MONTHLY MEETING MINUTES FOR Tuesday June 4, 2019

7:00 pm: Meeting called to order

President Ernie Baily opened the meeting, welcomed the group, led us in the Pledge of Allegiance.

Guest Introductions: The following people were introduced as our guests: Jay Russell, our newest member, has a nice '35 Ford Cabriolet that's being shipped from the east coast.

Comments from our President:

Club member projects: Ernie mentioned the possibility of having Club members talk about their car and related projects. At this time, Ernie is helping his brother work on Studebakers and Packards. Their goal: Get his brothers '56 Studebaker Golden Hawk running soon. It's been sitting for 20-plus years. His brother also has a couple of other classics, a '64 Studebaker Gran Turismo Hawk, and a '56 Packard.

Club Board meeting: This was held at the Ellerbrock's home last month. Members discussed upcoming Club activities including the Iskenderian company tour coming up on June 29. Speaking of June, this is the Drive-Your-Ford month.

Building Club membership: Members are encouraged to take Club business cards and hand them out at car shows, other meetings, etc. Other items were discussed including some 'maintenance' items and other topics that will help grow our club and keep it interesting.

Local tours: Ernie will be checking on setting some up, probably morning tours somewhere, eat lunch, then head home. First tour being considered is the Santa Suzanna railroad museum tour. This museum includes a big model railroad exhibit. This will be held on Friday July 26.

V-8 National magazine to go: Efforts are underway to make our V-8 Club National magazine past issues available on flash drive.

Upcoming Meets: The 2019 National Central Meet will be held on August 24-27 in Auburn, Indiana. International Meet will be held in Horton, Norway. Future meets for year 2020: The Eastern National Meet will be held on June 15-18, 2020.

Tours



VALLEY V8 CLUB TOUR - SANTA SUSANA DEPOT MUSEUM AND LUNCH - DRIVING TOUR!

Friday, July 26th

Meet at Rosie's BBQ: 9am

We will depart at 9:30am

We should arrive approx 10:am

**We've reserved space at the "Old Susana Cafe" for our group after
the museum tour around 11:30-11:45**

If questions give me a call! Thanks

"Donations Accepted" at the museum

Santa Susana Train Depot

6503 Katherine Rd. Simi Valley, Ca. 91360

The Santa Susana Train Depot was built in 1903 by the Southern Pacific Railroad to serve passengers and farmers. President Ernie has planned a 1-1/2 hour docent lead tour to learn the history, see the fascinating displays and the newly opened living quarters of the railroad agents!

Lunch will then take place at the historic Santa Susana Cafe!

Driving tour directions: Travel on Nordoff to Topanga Cyn Blvd. and turn right heading North to Santa Susana Pass Road. Now turn left for a scenic drive thru the Santa Susana Pass. Travel up and over the hill, then down into Simi Valley to Katherine Road. Just past the Church on the Left, turn onto Katherine Road, drive past the Train Depot Museum (only a couple of Handicapped parking spaces by the Museum) to the paved parking lot on the right.

Tour Organizers: Ernie Baily 805-428-0558, Ken Sapper 818-326-1286