



Drive Lines

Chapter #40

Aug 2018

Our 47th Year

Visit Our Websites

"valleyV8s.org"

"Facebook: Valleyv8s"

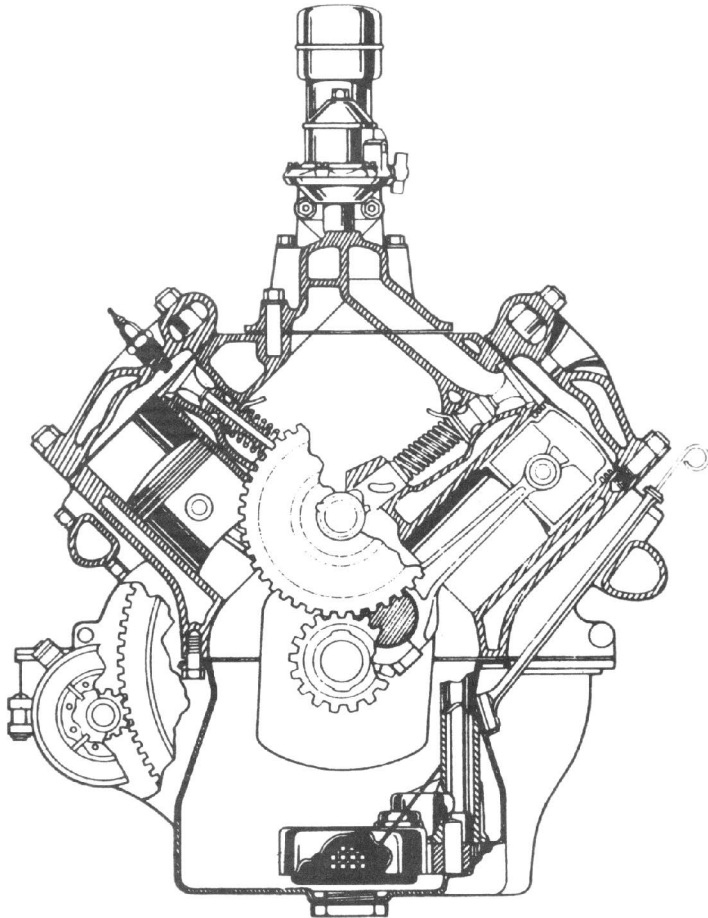

The Valley V8's
9700 Farralone, Chatsworth, Ca. 91311

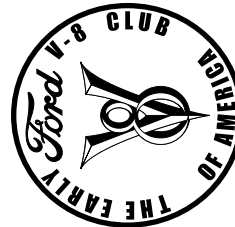

The Valley V8's

2018

President	Vaskin Hagopian	323-661-2044
Past Presidents	Don Durkee	
	Stan Miller	818-360-4812
Vice President	Steve Lehman	818-885-6938
Secretary	Rex Jaramillo	213-706-3854
Treasurer	Joan Sapper	818-249-5686
Tours	Kenney Sapper	818-249-5686
	Rich Carter	708-567-2393
Programs	Larry Caplan	818-363-2849
	Joe DiFatta	818-700-1939
Membership	Jerry Littner	818-632-9017
	Joan Sapper	818-249-5686
Drive Lines	Robert Glucksman	818-618-1395
	Jim Kelley	310-795-0704
Prize Raffle	Steve Boskovich	818-341-6876
50/50	Ken Sapper	818-380-5686
Ladies / Birthdays / Sunshine	Bobby Searl	818-353-6767
Name Badge	Karen Lehman	818-885-6938
Car of the Month	Jerry Jensen	805-491-3355
Web Master	Scott Dudrick	818-687-9836
Tech. Advisor	John Wolf	818-789-6201

Meeting: 1st Tuesday of the Month, 7:00p
 No host Dinner, Starting at 6:00p
 Rosie's BBQ & Grill, 8930 Corbin Ave.
 Northridge, Ca. 91324

Visit our Web Site: valleyv8s.org

Facebook: **Valleyv8s**

(<https://www.facebook.com/groups/579123315803014>)

Drive Lines is Published by

The San Fernando V8's Regional Group 40
 of the Early Ford V8 Club of America
 9700 Farralone, Chatsworth, Ca. 91311

The Valley V8's

Past Presidents

Jim Rowe	1971
Doug Peterson	1972
Don Durkee	1973-1974
Ed Warnock	1975
John Busk	1976
Chip Werstein	1977
Stan Misraje	1978
Bill Culp	1979
Al Spencer	1980
Larry Caplan	1981
Bob Rose	1982
Don Durkee	1983
Paul Kirk	1984
Kent Lowry	1985
Dave Sanborn	1986
John Kemmerer	1987
Dudley Ochsner	1988
Jerry Jensen	1989-1990
Joe DiFatta	1991
Chuck Shubb	1992-1993
George Richards	1994
Jerry Littner	1995
Dick Smith	1996
Chuck Mair	1997
Dennie Keene	1998
Rose Golt	1999
Don Stout	2000
Steve Boskovich	2001-2002
Joe DiFatta	2003
Wendi Potter	2004
Ken Sapper	2005-2006
Stever Batesole	2007
Harry Baker	2008-2009
Dave Bergman	2010
Randy Watson	2011-2012
Steve Boskovich	2013-2014
Stan Miller	2015
Don Durkee	2015
Vasken Hagopian	2016-2018

"Your Ad Here"
For only \$5.00 a month,
YOU

can have your
business card ad
right here

For more details,
Please call or Email Rob at
818-882-2002, / madmodelr@aol.com
Please put "Drivelines" in the subject
Please make all payments to
"Valley V8 Club"



Hello Fellow Members...
We would like to know more about
You, Your Car...

So, What I would like from our
members is a picture of you with your
car, with a small story. (1 Paragraph)
That way, We get to learn more about
our members, & we can put a face to
a name & car

Please make all submissions to ether
"Drivelines" at madmodelr@aol.com, or
"Drivelines" 9700 Farralone Ave.
Chatsworth, Ca. 91311

Thank You
Rob Glucksman, DL Editor

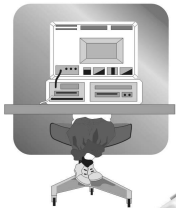

R.H.FACTOR GRAPHICS
Computer Graphics
Desktop Publishing



Robert Glucksman
Chatsworth, Ca. 91311
Office: 818-882-2002
Cell: 818-618-1395
madmodelr@aol.com

For all your Pre-Press needs

"We Fix 'Em"

THE RADIATOR WORKS

Auto Cooling System Services

(818) 701-0504

(818) 701-0536

18255 1/2 Parthenia St.

Northridge, CA 91325

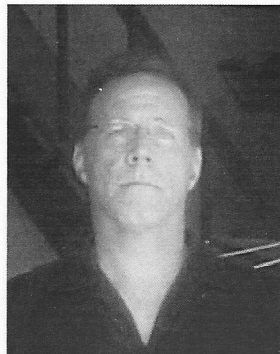

ARBONNE.
INDEPENDENT
CONSULTANT

Steven Lehman
Arbonne Independent Consultant
Consultant
23592171

Reset, Restore, Rebalance
Discover Ultimate Health,
C 818.517.1268

ArbonneForever@yahoo.com
www.stevenlehman.arbonne.com

**SPEEDWAY
ENGINEERING**



Ken Sapper
President

ken@1speedway.com
Office: 818.362.5865
Cell: 818.326.1286
Fax: 818.362.5608
13040 Bradley Avenue
Sylmar, CA. 91342
www.1speedway.com

Car of the Month:

Handled by Jerry Jensen, won by Phil Goeschl. Now here's another beauty put together by Phil: It's one swell '41 Mercury Eight Coupe, how rare is that! The Mercury was introduced in 1939 as Ford's mid-level line, an answer to GM's Pontiac and Oldsmobile. Edsel Ford was tasked by Henry to develop the line, named after the fleet-footed 'messenger of the gods'. Now Phil is known for his innovative ideas and attention to detail, blending tradition with practicality. And this Mercury doesn't disappoint! It's powered by a flathead Merc, bored and stroked to 270 cubic inches, ported and relieved, hot cam. Running a two-pot Weiand intake and capped with Navarro hi-compression heads, this sweet little mill is backed by a 5-speed with 20% overdrive, so the RPM drop in 5th is just enough. Out back is a Ford 9-inch for durability. And check out the stance. With big 'n little tires back/front and a 2-inch dropped front axle with reversed spring eyes, this Merc sits right! Inside is a stock gray cloth interior with jump seats in the back that contrasts nicely with the medium blue exterior paint. Nice work, Phil, you nailed it, congratulations!



VALLEY V8 TOUR PLANS!

California Oil Museum
1001 E. Main St.
Santa Paul, CA 93061

From fossils to “filler-er up” the California Oil Museum tells the story of the black bonanza! Housed in the original Union Oil Co. building. Fascinating docent led tour is planned!

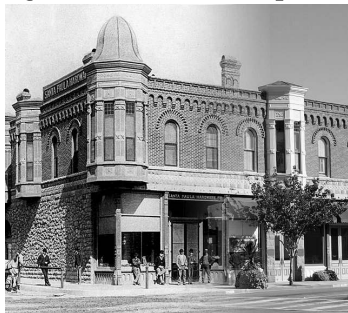

Friday, September 7 Cost \$4/person

Either meet at Woodley Park at 8:15 am and caravan to museum OR meet us there.

Arrive at museum at 10:00 am Tours begin at 10:30

At approximately 12:00 pm we will walk to Garman's Pub for delicious lunch.

After lunch you are welcome to explore more of Oil Museum, or local Train Museum, or enjoy an ice cream at Foster Freeze!

Sign up sheets will be sent around at August and September club meetings. Or call Joan Sapper (818-326-9685) or Scott Camolini (805-746-7296) to be put on list.

*And now for some
"Pressing" News*

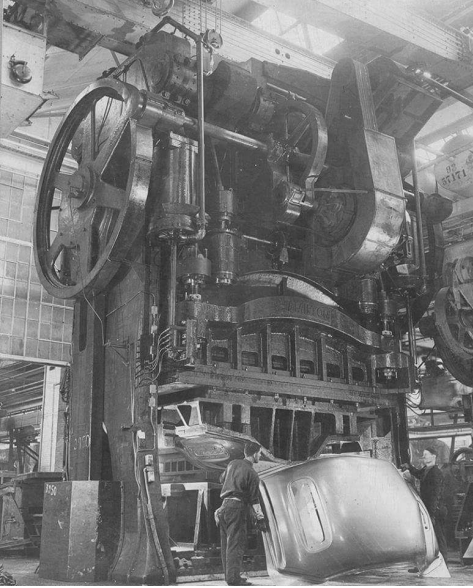

Our Next Meeting 7 Aug 18

Howdy---We have the Aug program lined up
Steve Kopito (Rob Gluckman's brother in law)....

Steve is the owner of a few Humvees--and buys
and sells them ----- WHY?!?!?!?!?
We will found out WHY!!!! Anyway it will be
a goooood program...

ALSO Scott Dourick is lined up for Sept--
(hopefully) he will tell us about property values
on MARS!!!!

Attend the August 7th meeting and get the
"True Story"

OK Take care STAY COOOL JoeD

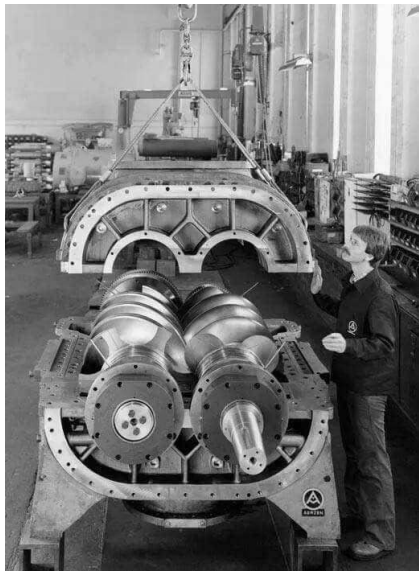

I changed my horn to
gunshot sounds



Now people move out of
the way much faster

The average human walks
900 MILES PER YEAR,
and drinks
22 GALLONS OF BEER,
Which means...
The average human gets
41 MILES PER GALLON.
Not bad!

Visit our Web Site: valleyv8s.org

Facebook: **Valleyv8s**

(<https://www.facebook.com/groups/579123315803014>)

Chapter 40 -- San Fernando Valley V-8's Club

Monthly Meeting Minutes for Tuesday July 10, 2018

7:00 pm: Meeting called to order

President Vasken Hagopian welcomed the group to the July Meeting, then led us in the Pledge of Allegiance.

Guest Introductions, other comments:

Welcome, guests! Joan Sapper introduced John Larson, our speaker for the evening, and Tom Larson, his brother. The Boskovich clan was well represented: Welcome to Sue Boskovich and their grandson Andrew. Guest Jim Ellerbrock also joined us. Comments from the top: Phil Hall, our President (past-president, most recently) of the Early Ford V-8 Club of America, National level, was present. Phil gave us some updates and comments about the Grand Nationals Event which was a great success, went off like clockwork. He announced that the approved 4th Edition Ford Flathead book is ready for print, and the '49-51 Mercury book is ½ done. Also, there will be a flash drive available around October, which will contain all editions of the V-8 Times magazine from 1972 to 2014, what a treasure! Finally, Phil discussed some of the ongoing political issues at the top levels. Good job, Phil, thanks for your diligence and for representing us so well! Thanks again, Sharon and Sylvia! Vasken gave thanks to the most excellent duo of Sylvia Duncan and Sharon Glucksman for the very informative CPR presentation last month. Robert Glucksman then handed out more CPR fliers, thanks again all!

Membership/Directory position: Vasken mentioned that Harry Baker is heavily involved in construction work at this time, so he handed over responsibilities of this position to Jerry Littner. Jerry did a fabulous job before, thanks for stepping up! Finally, Vasken thanked all the Board members for their contributions.

Flower power: President Vasken related some stories from the late 1960's when he was in his early 20's. At that time he took over an auto repair shop on Sunset Blvd. There were a lot of 60's flower children and hippies that lived in the area. Vasken told us of some interesting activities that he participated in, both as a shop owner and off-hours as friends with the hippies, heck, it was the psychedelic 60's, eh, Vasken?

Heat wave: Records are being set, and we're just starting our summer! Anyone looking forward to their next electric bill? Taxes, gotta love it! Vasken gave an account of some hefty taxes and penalties levied for a donation, then gave us advice on how avoid a similar plight.

Christmas Party: Vice President Steve Lehman announced that our Christmas Party is still on, it will be a self-serve lunch buffet the first Sunday in December.

Reports from Officers:

Secretary Rex Jaramillo: Everything OK.

Treasurer -- Joan Sapper: Everything OK. Joan gave a Club financial report.

Tours Ken Sapper:

California Oil Museum Tour is still being finalized, will still happen in September.

One-day Car Show in Las Vegas. Saturday August 18: This is a fund raiser for Las Vegas Speedway Children's Charity. It will be held at the South Point Hotel & Casino. 100,000 sq. feet of indoor parking space is being donated for the Car Show. There are special rates at the South Point Hotel for this event.

The Lynn Parks Cobra collection La Canada: Stay tuned on this one, it will be an extra special treat. Tentative plans are to view the Collection then go to lunch at a local restaurant in the La Canada area.

Drive Lines Editor Robert Glucksman: All good.

Membership/Directory Jerry Littner: All OK.

7:35 pm: Break called 7:55: Meeting resumed

Upcoming Car Shows: Vasken announced upcoming car shows and events: July 21: Glendale Brand Blvd. Cruise Night. July 22: Wounded Warriors Car Show, Redondo Beach. July 28: Woodies at the Beach Santa Barbara City College. August 5: Long Beach High Performance Swap Meet Long Beach Veteran's Stadium

Harold Johansen remembered: Blake Wilcox announced the passing of Harold Johansen. Harold had an engine machine shop, knew his stuff, and over the years, ran many race cars at Muroc, El Mirage, and Bonneville Salt Flats. He was 96 years old, and had even planned to race at Bonneville this year! He was a good man, and many Club members testified. He'll be racing El Mirage in the sky this year.

Car of the Month: Handled by Jerry Jensen, won by Phil Goeschl.

(Monthly Meeting Minutes Continued)

Ladies raffle: Handled by Bobbie Searl. Nice garden items were won by Bobbie 'not fixed, honest' Searl and Karen 'landscape' Lehman.

Birthdays for June: Bobbie Searl recognized the following beaming individuals: July 3 Mary Durkee July 9 Chuck Shubb July 15 Stan Miller July 17 Gerard Buck July 20 Charles Lohr July 23 Steve Boskovich July 25 Bob Everett July 26 Jimmy Cuzzo, Art Knapp

Name Badge: Handled by Karen Lehman, won by a contented Ken Stanton.

50/50 Drawing: Handled by Ken Sapper, won by John 'fortune 500' Fredricks.

Program: Ken Sapper introduced his friend and our speaker for the evening, John Larson. Now John has one of the more interesting hobbies known to man: Vintage license plates! Not just a hobby, but a business as well, John buys, sells, and restores license plates. He's been doing this for over 15 years now. For his presentation, he brought along a bunch of license plate samples and some very interesting information about CA license plates. A little history: In 1905, the state of California first required owners to register their motor vehicles. Interestingly, owners had to provide their own license plates for display. So they were able to buy a 'kit' and create their license plates, similar to how you'd set up the street number for your house. From 1920 to 1941, the state issued a new plate each year that displayed the registration year. That changed in 1942 with the U.S. involvement in World War II, when metal became a precious commodity. So in 1942-43, CA issued steel tags that affixed to the top of the plate. In 1944 owners were issued a registration tag affixed to the windshield. Some interesting facts and 'anomalies' about CA license plates: In 1912-13 California issued solid license plates for the rear of the vehicle and screen versions, same numbers, for the front, to prevent air blockage to the radiator. From 1914 to 1919, California license plates were porcelain, with 1914 painted a classy brick red with white lettering. After that, things were simplified and plates issued were made of plain steel. In the mid 1930's, if you had a commercial truck, the license plate had a 'PC' designation, pneumatic commercial(or 'SC')Solid commercial(which pertained to what kind of tires were used on the truck. After WWII, in 1947, some plates were made out of aluminum because of steel shortage. In the late 1930's, if you were a politician, you had a three-digit license plate. If you were a movie star, 4-digits. In conclusion, what's the best advice for working with the CA DMV to register vintage plates to your car? Be patient and do your homework/research ahead of time! That includes ensuring that the plates are 'clear'. John can help you with that. Thanks John for a most excellent presentation! Give him a call if you have any questions or if you need to restore or purchase vintage license plates. (626-590-0523).

)Secretary's Note(: Be watchful: Word is out on the street that some marshals from the DMV raided Bobs Big Boy, Toluca Lake recently, checking for illegal license plates, issuing tickets, confiscating, etc. This happened again at another car show, coincidentally one that was sponsored by a local police precinct!)They weren't connected with the DMV marshals(. Anyway, be on the lookout. Specialized plates and working with the DMV:)Advice from Scotty Cramolini(: If you have vintage license plates and go to the DMV to have them registered to your old car, ask for the 'Y.O.M.')Year of Manufacture(clerk or expert.

Raffle: Handled by Steve Boskovich. Many winners took home some mighty fine prizes. Thanks, Steve for handling the Raffle.

Vasken: Reminded us of the next Club meeting date, Aug 7 Tuesday. Invite your friends, and drive home safely.

8:52 pm: Meeting adjourned.

Minutes submitted by Rex Jaramillo



FROM THE PRESIDENT.

It was nice to see all the classic Fords at our July meeting. Phil Goeschl won the car if the month for his fabulous 41 Mercury.

Enjoying the heat? 60 years in L.A., July, August, and September were always the hot months, with heavy eye burning smog in the 60,s and 70,s. It is the same heat with no smog or very little smog. Let us give the EPA credit.

John Larson gave us good information on license plates. Old plates, New plates, modern plates. As much as we think we know about license plates, there is more to learn. I have always thought that plates were made by inmates. I was wrong. If you buy license plates from a swap meet, and it is not DMV approved, you just lost your money. Be careful.

Phil Hall gave us some turbulent news for the Nationals, I hope they solve the problem. Eventually It trickles down to the regions/chapters.

Joe (four more years) DiFatta, you are missed, where are you?

The 34 Ford is at ABS brakes in Santa Anna, getting electric power steering installed. It is a simple process, and keeping the original column, and the steering wheel. (no tilt column). No pump, no belt, no p.s. fluid.

Most all new cars come with electric steering, and electric Air Conditioning. There are no fan belts to draw horse power from the motor, and no p.s. fluid anymore, and better fuel milage.

By the time you read this letter, we have gone to the Old Fashion Day at the park, in Marina Del Rey with classic yachts, and vintage classic cars. Thank you Gerard and Pamela Buck for your hard work, inviting us to this Wonderfull event.

Evelyn and I are going to Costa Rica in September. We will make the September 4th. Meeting and on the 5th we are at LAX. We will return just in time for the October 2nd. meeting. We miss the white face monkeys on our trees, and swimming with the big turtles in the warm Pacific Ocean.

“Those who love deeply never grow old: they may die of old age, but they die young.”

Please bring a friend to the meeting.

Vasken Hagopian

