



Drive Lines

Chapter #40

Sept 2018

Our 47th Year

Visit Our Websites

"valleyV8s.org"

"Facebook: Valleyv8s"

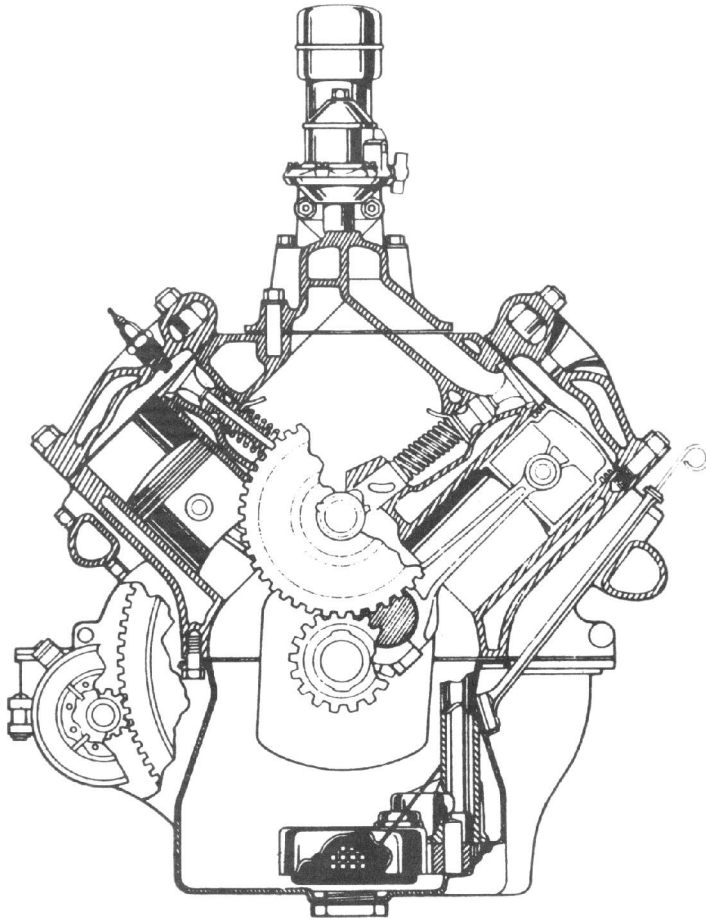

The Valley V8's
9700 Farralone, Chatsworth, Ca. 91311

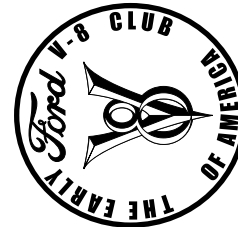

The Valley V8's

2018

President	Vaskin Hagopian	323-661-2044
Past Presidents	Don Durkee	
	Stan Miller	818-360-4812
Vice President	Steve Lehman	818-885-6938
Secretary	Rex Jaramillo	213-706-3854
Treasurer	Joan Sapper	818-249-5686
Tours	Kenney Sapper	818-249-5686
	Rich Carter	708-567-2393
Programs	Larry Caplan	818-363-2849
	Joe DiFatta	818-700-1939
Membership	Jerry Littner	818-632-9017
	Joan Sapper	818-249-5686
Drive Lines	Robert Glucksman	818-618-1395
	Jim Kelley	310-795-0704
Prize Raffle	Steve Boskovich	818-341-6876
50/50	Ken Sapper	818-380-5686
Ladies / Birthdays / Sunshine	Bobby Searl	818-353-6767
Name Badge	Karen Lehman	818-885-6938
Car of the Month	Jerry Jensen	805-491-3355
Web Master	Scott Dudrick	818-687-9836
Tech. Advisor	John Wolf	818-789-6201

Meeting: 1st Tuesday of the Month, 7:00p
 No host Dinner, Starting at 6:00p
 Rosie's BBQ & Grill, 8930 Corbin Ave.
 Northridge, Ca. 91324

Visit our Web Site: valleyv8s.org

Facebook: **Valleyv8s**

(<https://www.facebook.com/groups/579123315803014>)

Drive Lines is Published by
 The San Fernando V8's Regional Group 40
 of the Early Ford V8 Club of America
 9700 Farralone, Chatsworth, Ca. 91311

The Valley V8's

Past Presidents

Jim Rowe	1971
Doug Peterson	1972
Don Durkee	1973-1974
Ed Warnock	1975
John Busk	1976
Chip Werstein	1977
Stan Misraje	1978
Bill Culp	1979
Al Spencer	1980
Larry Caplan	1981
Bob Rose	1982
Don Durkee	1983
Paul Kirk	1984
Kent Lowry	1985
Dave Sanborn	1986
John Kemmerer	1987
Dudley Ochsner	1988
Jerry Jensen	1989-1990
Joe DiFatta	1991
Chuck Shubb	1992-1993
George Richards	1994
Jerry Littner	1995
Dick Smith	1996
Chuck Mair	1997
Dennie Keene	1998
Rose Golt	1999
Don Stout	2000
Steve Boskovich	2001-2002
Joe DiFatta	2003
Wendi Potter	2004
Ken Sapper	2005-2006
Stever Batesole	2007
Harry Baker	2008-2009
Dave Bergman	2010
Randy Watson	2011-2012
Steve Boskovich	2013-2014
Stan Miller	2015
Don Durkee	2015
Vasken Hagopian	2016-2018

"Your Ad Here"
For only \$5.00 a month,
YOU

can have your
business card ad
right here

For more details,
Please call or Email Rob at
818-882-2002, / madmodelr@aol.com
Please put "Drivelines" in the subject
Please make all payments to
"Valley V8 Club"



Hello Fellow Members...
We would like to know more about
You, Your Car...

So, What I would like from our
members is a picture of you with your
car, with a small story. (1 Paragraph)
That way, We get to learn more about
our members, & we can put a face to
a name & car

Please make all submissions to ether
"Drivelines" at madmodelr@aol.com, or
"Drivelines" 9700 Farralone Ave.
Chatsworth, Ca. 91311

Thank You
Rob Glucksman, DL Editor

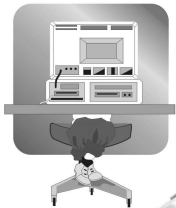

R.H.FACTOR GRAPHICS
Computer Graphics
Desktop Publishing



Robert Glucksman
Chatsworth, Ca. 91311
Office: 818-882-2002
Cell: 818-618-1395
madmodelr@aol.com

For all your Pre-Press needs

"We Fix 'Em"

THE RADIATOR WORKS

Auto Cooling System Services

(818) 701-0504

(818) 701-0536

18255 1/2 Parthenia St.

Northridge, CA 91325

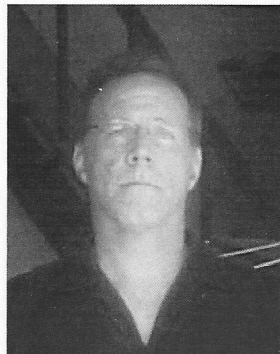

ARBONNE.
INDEPENDENT
CONSULTANT

Steven Lehman
Arbonne Independent Consultant
Consultant
23592171

Reset, Restore, Rebalance
Discover Ultimate Health,
C 818.517.1268

ArbonneForever@yahoo.com
www.stevenlehman.arbonne.com

**SPEEDWAY
ENGINEERING**



Ken Sapper
President

ken@1speedway.com
Office: 818.362.5865
Cell: 818.326.1286
Fax: 818.362.5608
13040 Bradley Avenue
Sylmar, CA. 91342
www.1speedway.com

Car of the Month: Handled by Jerry Jensen, awarded to Steve Boskovich and his amazing '51 Ford convertible. Steve has owned this fine Ford for over twenty years. During that time, he's gone through the car from front to back, performing extensive renovations and upgrades. So this car is sorted out nicely, all the mechanicals have been renewed or rebuilt as needed. Check out under the hood: There's a nicely detailed 8BA flathead with some nice upgrades, including Fenton headers, and a 12-volt conversion for hotter spark and more reliability. And this little drop top pulls nicely on the street, those dual pipes sound mellow! The body is laser-straight, refinished in the original Hawaiian Bronze Metallic with pinstriping tastefully applied. An extraordinary car, a beautiful time capsule, congratulations, Steve!



Ken Sapper Three Time Track Champion Gets Ride of A Lifetime!

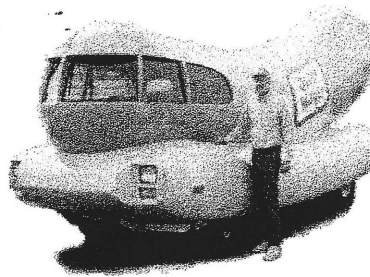

Sylmar, Ca. Feb 1, 1998

Kolokai Racing announced today that Ken Sapper was now the full time driver of the famous Weinermobile. "This like a dream for me " said the veteran driver.

" I didn't want to say any thing about before it was for sure, but now I can tell the whole world "

"Ken was our first choice I'm glad we could get a driver with his experience," said Oscar Mayer, President and head wiener of Oscar Mayer. " We asked a lot of drivers before Ken said yes. "



Ken Sapper hard at work

When Ken started racing, a long time ago, he probably never figured he would be driving anything like the world famous Weinermobile. "It is hard for me to grasp what an effect this will have on my driving career" said Ken taking a brief moment away from his duties as president of Speedway Engineering. "This job

keeps me pretty darned busy, but a chance like this comes around only once in a lifetime."

As happy as Ken seemed his crew took a somewhat different view of his good fortune.

Scott Crosby, Ken's longtime Crew chief, was over heard saying " As long as the beer is cold and everybody stays the hell out of my way I don't give a crap what kind of pile of junk Ken wants to drive I'll work on it. And where is the damn 7 11 around here!"

Crew member and psychic advisor Joe Landy was oddly quiet at first, but after he got going we were sorry we asked. Here are is just a small sample of what he had to say; "I always knew that Ken was destined for greatness...I raised him from a pup...Always check for full throttle and give it more toe out..."

Engine builder Vince "liz-zard" Vacido took a more careful approach " I kind of like the shape. What cam do they have in this thing it? "

Ken summed it best when he said " The first time I go sailing into the corner at full speed you can be sure I will be thinking 'Wow I'm driving a big weenie!"

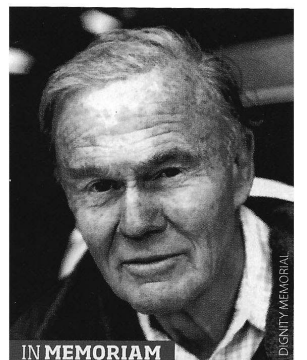

IN MEMORIAM

Harold Johansen dies at 94

Land speed-racing veteran Harold Johansen, whose competition career spanned more than 70 years, died in his sleep June 30 at age 94.

Johansen, a retired Los Angeles firefighter and movie consultant, specializing in fire and explosive safety, racked up 60 land speed records and joined the Bonneville 200 MPH Club during his years racing.

Born in the Lincoln Heights section of Los Angeles in June 1924, Johansen got his automotive education in part through high school vocational classes, and in part after buying an already hopped-up 1929 Ford Model A roadster from an impound lot before he got his driver's license.

In 1974, he blew past the 200-mph mark in a C/Gas Roadster and set a record speed of 208.86 mph.

He attempted another 200-mph record in a car powered by an early Ford four-cylinder, but the closest Johansen ever got to his goal was 164 mph.



*And now for some
"Pressing" News*

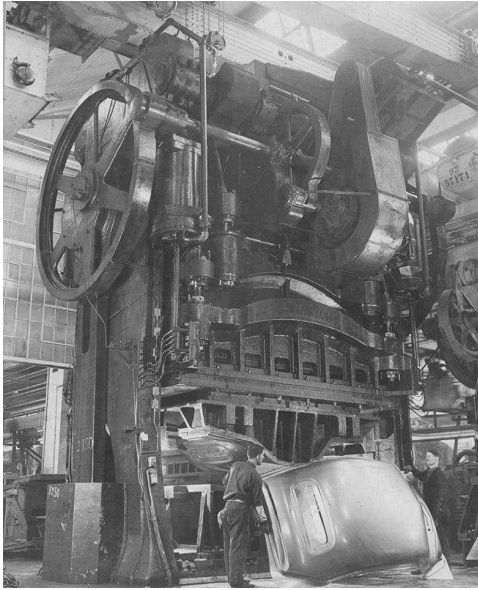

Our Next Meeting 4 Sept 18

ALSO Scott Dourick is lined up for Sept--
(hopefully) he will tell us about property values
on MARS!!!!

Summer BBQ
sunday, 23 Sept 18
4pm.

Hosted by Steve & Sue Boskovich
10745 Delco Ave, Chatsworth
818-341-6876

Please sign up to bring a
Hot or Cold side dish or Dessert

A husband died. A few years later the wife died. As she got to heaven she saw her husband and ran up to him with tears in her eyes. "Darling, oh how I've missed you!" The husband extends his arms stopping her from embracing him and says, "Woah there woman. The contract was until death."

**Don't piss off old people.
The older we get,
the less
"Life In Prison" is a deterrent.**

Visit our Web Site: valleyv8s.org

Facebook: **Valleyv8s**

(<https://www.facebook.com/groups/579123315803014>)

Chapter 40 -- San Fernando Valley V-8's Club

Monthly Meeting Minutes for Tuesday Aug 7, 2018

7:00 pm: Meeting called to order

President Vasken Hagopian welcomed the group to the July Meeting, then led us in the Pledge of Allegiance.

Guest Introductions, other comments:

Welcome, guests/new members: The Ellerbrock's, Jim and Val were with us. However, they're now full-fledged members, welcome aboard, you two! Club Barbecue coming up! Steve Boskovich announced our upcoming V-8 Club Annual Barbecue, Sunday Sept. 23, will be held at the Boskovich residence. A sign-up sheet was passed around. Weather change: Vasken provided some views on weather conditions and what some believe to be climate change. Young drivers: According to information Vasken shared, the human brain isn't fully developed until mid/late 20's, leading some to believe that full maturity and judgement skills aren't completely present until around that age. And there's a changing trend: Female drivers are having more accidents than their male counterparts, same age. The Trader Joe Tragedy: Vasken shared thoughts about that recent situation involving the Trader Joe's store in Silver Lake a few blocks from his home. It was a very unfortunate and shocking occurrence. Fun day in Marina del Rey: Rex Jaramillo reported on the Classic Yacht Association Day in the Park which took place on Sunday July 29. It was held in picturesque Marina del Rey, the weather was wonderful, and many car clubs including ours were well represented. The yacht owners were very gracious, providing on-board tours of their boats, and a continental breakfast was served. Many beautiful cars were on display, Now we missed having our own Gerard Buck run the car show part, but Alex did a great job his first year of coordinating that part of the activity. In all, it was a most excellent event! Christmas Party update: V.P. Steve Lehman has done a great job setting up our Christmas party: Sunday December 2, a brunch at the Knollwood Country Club: Members \$25 each, non-members \$30. Straws and the environment: Vasken mentioned a movement afoot to replace plastic straws with paper ones due to environmental considerations. Vasken and Evie, bon voyage! After the September meeting, Vasken and Evie will be leaving for a Costa Rica vacation. Stay tuned for an entertaining recap when they return.

Reports from Officers:

Secretary Rex Jaramillo: Everything OK.

Treasurer -- Joan Sapper: Everything OK. Joan gave a Club financial report.

Tours Ken and Joan Sapper: California Oil Museum Tour will be Friday September 7. Meet at Woodley Park 8:15 am, cruise over as a group, or drive to the Museum on your own. The Museum is located at 1001 E Main St, Santa Paula. Tour starts at 10:30 am sharp. There's a complete oil drilling rig housed onsite, many gas company signs are on display along with vintage gas pumps. And the original union oil company building is still standing on the Museum property! After the tour, around 11:45 am, we'll drive to Garman's Restaurant & Irish Pub for lunch. After lunch we're on our own, it'll be a swell day, thanks Sappers, also Scott Cramolini for setting this up! For more info, contact Joan Sapper)818(326-9685 or Scott Cramolini)805(746-7296.

Drive Lines Editor Robert Glucksman: All is going well. Robert is having shoulder surgery on Thursday August 16, we wish you well, Robert.

Membership/Directory Jerry Littner: All OK. Will continue in this position until end of this year.

7:33 pm: Break called 7:55 pm: Meeting resumed

Car of the Month: Handled by Jerry Jensen, awarded to Steve Boskovich and his amazing '51 Ford convertible.

Ladies raffle: Handled by Bobbie Searl. Nice garden items were won by landscape experts Sandy Norris and Pamela Buck.

Birthdays for August: Bobbie Searl recognized the following overjoyed individuals: Aug 2 Oliver Calibet Aug 3 Carole Jensen Aug 4 Christine Varney Aug 5 Pamela Buck Aug 9 Debbie Bergman Aug 11 Mary Finley Aug 12 Michael Ewing Aug 22 Karen Lehman.

(Monthly Meeting Minutes Continued)

Anniversaries for August, celebrating years of wedded bliss:

Aug 2: Rex & Reenie Jaramillo

Aug 6 Steve & Sue Boskovich

Name Badge: Handled by Karen Lehman, won by Gerard Buck.

50/50 Drawing: Handled by Ken Sapper, won by Don Stout.

Program: Our speaker was introduced by Joe DiFatta. Steve Kopito has one of the most fun jobs known to man: He's an independent car sales broker, buys and sells interesting collectible cars. One of his specialties is HMMWV's (High Mobility Multipurpose Wheeled Vehicle), or 'HUMVEE's'. The running gear is tucked up inside, which provides for tons of ground clearance but cuts into vehicle occupant space. And it has some amazing mechanicals, including full-time 4 wheel drive and fully independent suspension, a very capable off-road vehicle. Background: In the early 1980's, the AM General Company or AMG, located in South Bend, Indiana, contracted with the government to produce HUMVEE's for the military. Then in 1992, a civilian version of the HUMVEE, known as the Hummer, went on sale. Turns out that Arnold Schwarzenegger was very influential in convincing AMG to build a HUMVEE for civilian sales/use! The hulking, attention-grabbing road warrior weighed some 10,000 pounds and got less than 10 miles per gallon.)President Vasken can attest to that!(In 2002, AMG started assembling the HUMMER H2 in a new commercial manufacturing center in Mishawaka, Indiana. By year 2012, nearly 300,000 Humvee's had been manufactured. HUMVEE's being produced for our military are now fully armored, designed to better protect our soldiers. So what do used HUMVEE's go for? The prices aren't too bad, considering how well-built and durable they are, generally between \$5 and \$12k. The HUMVEE is truly an off-road all terrain vehicle. In stock form, they're designed to operate in 3 feet of water. So engine intake and exhaust are plumbed accordingly. However, Steve has seen HUMVEE's driving down into lakes, submerge completely, then come back up and keep going! These particular vehicles are special-equipped with a pressurization system for the engine and drive train to keep water from ingressing and causing damage. What's the quality level for HUMVEE's? Pretty good, for the most part. They've had their problems, though. In year 2002, a batch of them were sold with defective drive train control units, which caused fires. So what's Steve's job really like? Well, he usually buys HUMVEE's and ships them. In the past few years, Steve has handled sale for over 200 of these vehicles. But selling them isn't a slam-dunk: Thanks to California state DMV policies, HUMVEE's are only eligible for 'off-road' sales, meaning that most are sold and sent out of the state or to countries such as Germany, the Netherlands, Australia, Japan, hey, everyone wants what they can't have! Now Steve has bought them in all states of running/repair/disrepair. He's done a few restorations but finds it's not that profitable. Many owners and companies have modified them into stretch limo's, comfort-vehicles, often customized to the owner's taste. Yep, there's a real cult-following for HUMVEE's! And in case you're interested or need more information, Steve even has his own website: stevekopito@militaryjeep.com. Thanks Steve for a most excellent presentation!

Raffle: Handled by Steve Boskovich. Many winners took home some fine prizes, some more than one.)Not fixed(. Thanks, Steve for handling the Raffle.

Vasken: Reminded us of the next Club meeting date, Sept. 4 Tuesday. Invite your friends, and drive home safely.

8:40 pm: Meeting adjourned.

Minutes submitted by Rex Jaramillo



stevekopito@militaryjeep.com

FROM THE PRESIDENT.

Hot weather: what can we do about it? Try not to think of the hot weather too much, just do what you do normally, and concentrate on your project, but be aware of the high temperature. Drink warm, or hot drinks, try to stay away from the very cold drinks. We lived in Jordan from 1950 to 1959, my dad was an auto electrician. Yes in those days they used to rebuild batteries, generators, starters, there were no parts houses like today to replace components. I remember when I was about 10 years old my dad would take me out to the desert where the Beduins lived in the desert tents, as you see it in the movies, at over 120 degrees. He would fix the old Land Rovers, and those Army jeeps, remember there were no 12 volt systems. Did they have Pepsi machines? They survived by drinking hot drinks, hot tea, etc. but no cold drinks. If you drink a cold drink you are lowering your body temp, and if the air temp is 110degrees, there is a big gap, and you suffer. But if you drink a hot drink you are raising your body temp. Higher and the gap is smaller, you will not suffer as much. Just think of this theory.

Our guest speaker, Steve Kopito, gave us great information about Humvees, & he is very knowledgeable with the California DMV rules. It was very educational, especially that we own a Hummer H2.

I will be there for the Sept. 4th meeting, and on the morning of the 5th we are at LAX to Costa Rica. Returning just in time for the October 2nd meeting.

Name badges, if you lost your name badge, please buy one and join the rest of the club members. Yes .25 cents is cheaper than buying a badge, but!!!!!!

I regret that we will miss the September 7th California Oil Museum tour. Thank you Kenny, Joanne and Scotty for arranging this tour. Also will miss the summer BBQ party on September 23rd. Thank you Steve and Sue for opening your home again for our club. (will a doggy bag survive for 9 days)? Thank you board of directors for making my job easier, and making the club shine and run smoothly.

Robert, good luck with your shoulder surgery, we all pray for a speedy recovery. You are the "man" the editor, head honcho. You and Rex are the new kids on the block, and both of you are doing an outstanding job, my hat is off for you. Remember this: "Life is like a car with a broken gas gauge. You never know how far you're going to go, so you have to do all you can to enjoy the ride."

Vasken Hagopian

