



# Drive Lines

Chapter #40

Oct 2018

Our 47th Year

Visit Our Websites

"valleyV8s.org"

"Facebook: Valleyv8s"

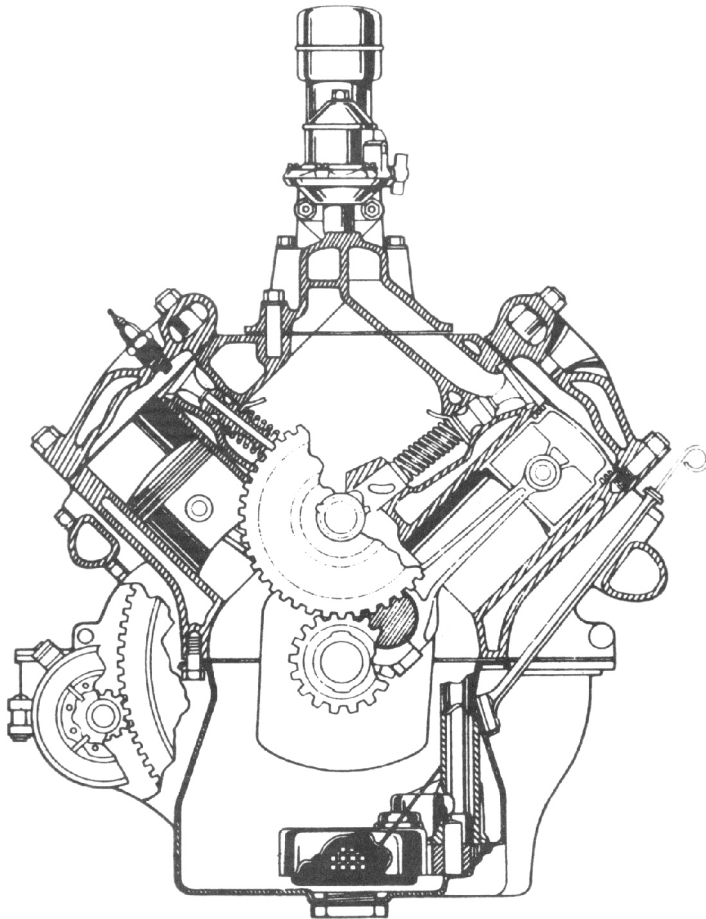

The Valley V8's  
9700 Farralone, Chatsworth, Ca. 91311



# The Valley V8's

## 2018

President	Vaskin Hagopian	323-661-2044
Past Presidents	Don Durkee	
	Stan Miller	818-360-4812
Vice President	Steve Lehman	818-885-6938
Secretary	Rex Jaramillo	213-706-3854
Treasurer	Joan Sapper	818-249-5686
Tours	Kenney Sapper	818-249-5686
	Rich Carter	708-567-2393
Programs	Larry Caplan	818-363-2849
	Joe DiFatta	818-700-1939
Membership	Jerry Littner	818-632-9017
	Joan Sapper	818-249-5686
Drive Lines	Robert Glucksman	818-618-1395
	Jim Kelley	310-795-0704
Prize Raffle	Steve Boskovich	818-341-6876
50/50	Ken Sapper	818-380-5686
Ladies / Birthdays / Sunshine	Bobby Searl	818-353-6767
Name Badge	Karen Lehman	818-885-6938
Car of the Month	Jerry Jensen	805-491-3355
Web Master	Scott Dudrick	818-687-9836
Tech. Advisor	John Wolf	818-789-6201

Meeting: 1st Tuesday of the Month, 7:00p  
 No host Dinner, Starting at 6:00p  
 Rosie's BBQ & Grill, 8930 Corbin Ave.  
 Northridge, Ca. 91324

Visit our Web Site: [valleyv8s.org](http://valleyv8s.org)

Facebook: **Valleyv8s**

(<https://www.facebook.com/groups/579123315803014>)

Drive Lines is Published by

The San Fernando V8's Regional Group 40  
 of the Early Ford V8 Club of America  
 9700 Farralone, Chatsworth, Ca. 91311

# The Valley V8's

## *Past Presidents*

Jim Rowe	1971
Doug Peterson	1972
Don Durkee	1973-1974
Ed Warnock	1975
John Busk	1976
Chip Werstein	1977
Stan Misraje	1978
Bill Culp	1979
Al Spencer	1980
Larry Caplan	1981
Bob Rose	1982
Don Durkee	1983
Paul Kirk	1984
Kent Lowry	1985
Dave Sanborn	1986
John Kemmerer	1987
Dudley Ochsner	1988
Jerry Jensen	1989-1990
Joe DiFatta	1991
Chuck Shubb	1992-1993
George Richards	1994
Jerry Littner	1995
Dick Smith	1996
Chuck Mair	1997
Dennie Keene	1998
Rose Golt	1999
Don Stout	2000
Steve Boskovich	2001-2002
Joe DiFatta	2003
Wendi Potter	2004
Ken Sapper	2005-2006
Stever Batesole	2007
Harry Baker	2008-2009
Dave Bergman	2010
Randy Watson	2011-2012
Steve Boskovich	2013-2014
Stan Miller	2015
Don Durkee	2015
Vasken Hagopian	2016-2018



**"Your Ad Here"**  
*For only \$5.00 a month,*  
**YOU**

can have your  
business card ad  
right here

**For more details,**  
**Please call or Email Rob at**  
**818-882-2002, / madmodelr@aol.com**  
**Please put "Drivelines" in the subject**  
**Please make all payments to**  
**"Valley V8 Club"**



Hello Fellow Members...  
We would like to know more about  
You, Your Car...

So, What I would like from our  
members is a picture of you with your  
car, with a small story. (1 Paragraph)  
That way, We get to learn more about  
our members, & we can put a face to  
a name & car

Please make all submissions to ether  
"Drivelines" at madmodelr@aol.com, or  
"Drivelines" 9700 Farralone Ave.  
Chatsworth, Ca. 91311

*Thank You*  
Rob Glucksman, DL Editor

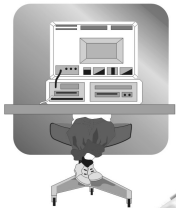

**R.H.FACTOR GRAPHICS**  
*Computer Graphics*  
*Desktop Publishing*



**Robert Glucksman**  
**Chatsworth, Ca. 91311**  
**Office: 818-882-2002**  
**Cell: 818-618-1395**  
**madmodelr@aol.com**

*For all your Pre-Press needs*

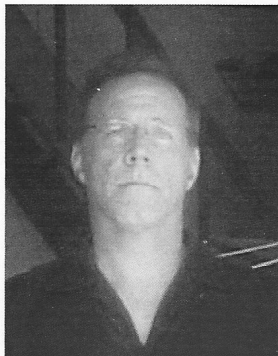

ARBONNE.  
INDEPENDENT  
CONSULTANT

**Steven Lehman**  
Arbonne Independent Consultant  
Consultant  
23592171

Reset, Restore, Rebalance  
Discover Ultimate Health,  
C 818.517.1268

ArbonneForever@yahoo.com  
www.stevenlehman.arbonne.com

**SPEEDWAY**  
**ENGINEERING**



**Ken Sapper**  
**President**  
ken@1speedway.com  
Office: 818.362.5865  
Cell: 818.326.1286  
Fax: 818.362.5608  
13040 Bradley Avenue  
Sylmar, CA. 91342  
www.1speedway.com

**Car of the Month:** Handled by Jerry Jensen, awarded to **Walt Hanna** and his '47 Ford 4-door police car. An interesting twist: This '47 was a former LA City police car that had emigrated to Oregon. So in 2016 when Walt bought the '47, it was a kind of homecoming for the old Ford. He and a friend drove up to Oregon and towed it back to CA. Now it hadn't run in awhile, so Walt cleaned out the fuel lines, replaced the gas tank, ignition points and spark plugs, added fresh gas, and it fired right up! Since then, Walt has added servo-style brakes from a Ford F-1 truck, which made a real difference in stopping power. He also converted to 12 volts for reliability. It's a six! The most interesting feature of this police car is the engine: Open the hood and you see a very clean 6-cylinder! Now this engine was introduced in 1941, Ford's first flathead six, and designated the G-series engine. Displacing 226 cubic inches, it produced 90 hp. And like the V-8, it was also a flathead or L-head design. This new engine replaced the 'V-8 60'. Remember that one? 136 cubic inches, 60 horsepower the 'economy' flathead V8 introduced in the 1937 Ford. So the new G-series six had a fairly long production run starting in 1941, ending in 1951. For model year 1952, a completely new 215 cubic inch OHV six-cylinder was introduced. A six in a police car? So why did Walt's Ford come with a six vs. a V-8? Well, back in that day, vehicles were 'batch-purchased' by LA City for fleet-use. V-8 or six, it didn't matter to the City, cost was the main consideration. So Walt ended up with one very unique Ford. And it's a beauty! Congratulations Walt, well deserved!

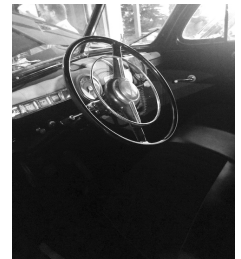

---

---

**Coffee n Kix Reunion**  
**Saturday October 6th, 8:00 AM,**  
**22501 Itasca, Chatsworth**



*And now for some  
"Pressing" News*

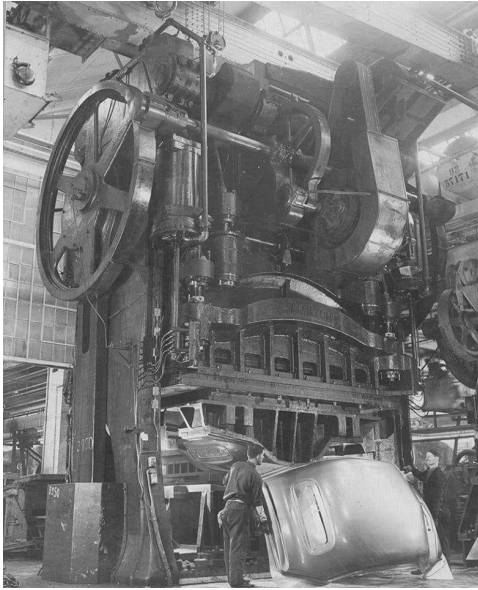

## **Our Next Meeting 2 Oct 18**

**Summer BBQ**

**Sunday, 23 Sept 18**

**4pm.**

**Hosted by Steve & Sue Boskovich**

**10745 Delco Ave, Chatsworth**

**818-341-6876**

**Please sign up to bring a**

**Hot or Cold side dish or Dessert**



## **OCTOBER AUCTION Tuesday, 02 Oct 18**

**Our yearly auctions...sooooo,**

**Things are needed...If anyone needs assistance  
getting items to the meeting call**

**Joe D (661) 478 - 1939...Joe and Steve Boskovich  
will be the Auctioneers!**

**OK Have a goood weekend JoeD**



www.shutterstock.com - 618026321



www.shutterstock.com - 29862295

Visit our Web Site: [valleyv8s.org](http://valleyv8s.org)

Facebook: **Valleyv8s**

(<https://www.facebook.com/groups/579123315803014>)

## Chapter 40 -- San Fernando Valley V-8's Club

### Monthly Meeting Minutes for Tuesday Sept 4, 2018

#### **7:00 pm: Meeting called to order**

President Vasken Hagopian welcomed the group to the September Meeting, then led us in the Pledge of Allegiance.

#### **Guest Introductions, other comments:**

Welcome, guests: Chip Werstein past president from 1977 was one of our guests. He had a '37 Ford Phaeton at the time, still has it, and plans to re-join the Club. Welcome back, Chip!

**V-8 Club Summer BBQ:** Steve Boskovich announced details about the upcoming Club Summer Barbecue: Sunday September 23, 4 pm at the home of Steve and Sue Boskovich. 10745 Delco Ave. Chatsworth. A sign-up sheet was passed around.

**Annual Club Auction:** Will be conducted at our next Club meeting on October 2. It's a fund-raiser, and Steve encouraged us to look in our garages for items to bring for the Auction. If you have larger items, Steve offered up his Ford F-250 truck to help haul them. Now that's dedication, thanks, Steve!

**Comments from our President:** Labor Day is coming, Fall is just around the corner, hot weather is gone (not quite!), students are back in school so there's more traffic on the freeways, and there are two good football teams in LA: USC and UCLA. Vasken and Evie are going back to Costa Rica, leaving tomorrow morning. They will be back in time for the October meeting. Safe travels, Vasken & Evie.

**Officers needed:** Our club is looking for people to fill leadership board member positions for next year. Our president asked us to consider supporting one of these positions.

**Upcoming California Oil Museum tour.** Thanks again to Ken and Joan Sapper, also Scott Cramolini for setting this up.

**Christmas Holiday brunch at Knollwood:** All is arranged for this fantastic event: 10 am Sunday December 2. \$25 for members \$30 for guests. If you haven't done so, please sign up, we need a head count.

**Famous Drag racer passes away:** Don 'the Mongoose' Prudhomme, an iconic drag racer has died. This was announced in the latest issue of DRIVE magazine.

**HOV stickers are expiring:** If you drive a vehicle that qualifies for an HOV sticker (High Occupancy Vehicle), the present ones, green in color, are expiring in December of this year. They will be replaced with red stickers. Vasken has applications for new passes. There's not a mike he doesn't like: Vasken announced the need for a new PA system. He'll do some cost research and run it by the Board. Our new valet: Robert Glucksman did a good job of acquiring parking spaces and helping park old Fords that drove to our Meeting tonight, thanks Robert for a job well done.

#### **Reports from Officers:**

**Secretary** - Rex Jaramillo: Everything OK.

**Treasurer** - Joan Sapper: Everything OK. Joan gave a Club financial report. She encouraged us to bring auction items for next months' meeting.

**Tours** - Ken and Joan Sapper: California Oil Museum Tour will be Friday September 7. Meet at Woodley Park 8:15 am, cruise over as a group, or drive to the Museum on your own

**Upcoming Car Events:** Vasken shared info on the following:

Sept. 9: Long beach High Performance Swap Meet, Veteran's Stadium, Long Beach.

Sept. 29: Car Show and drive-in movie, 4 to 9 pm, Paramount Ranch, Aurora Hills.

Oct. 6: Southern California Falcon Club, LA State Historic Park Spring Street, Los Angeles.

Oct. 6: Coffee & Kix with Don Stout, 22401 Itasca St. Chatsworth. Oct 7: Road Kings Car Show, Santa Anita Park.

**Drive Lines Editor** - Robert Glucksman: All is going well. Robert had shoulder surgery on Thursday August 16. He thanked us for our well wishes, and we wish you continued good recovery, Robert.

**7:22 pm: Break called / 7:45 pm: Meeting resumed**

**Car of the Month:** Handled by Jerry Jensen, awarded to Walt Hanna and his '47 Ford 4-door police car.

**Ladies raffle:** Handled by Bobbie Searl. Nice garden items were won by green thumbs Reenie Jaramillo and Sandrine Cutright.

**Birthdays for August:** Bobbie Searl recognized the following euphoric individuals:

Sept 3 - Reenie Jaramillo / Sept 9 - Joan Sapper / Sept 18 - Art Fernandez / Sept 29 - Joe Nuccitelli / Sept 30 - Dominic Nuccitelli  
Anniversaries for September: Sept. 21 - Vasken & Evie Hagopian

**Name Badge:** Handled by Karen Lehman, won by a bucks-up Brandon Jacobson.

**50/50 Drawing:** Handled by Ken Sapper, won by an opulent Oliver Calibet.

**(Monthly Meeting Minutes Continued)**

**Program:** Our speakers for the evening were introduced by *Larry Caplan*. They included *Ed Warnock*, *Jerry Jensen*, *Ernie Baily*, and *Chip Werstein*. Ed Warnock was our first speaker. For Ed, it started with a local Meet in Santa Rosa in late 1972 where Ed met Dick Durkee who told him about the Valley V8's. He went to a meeting, then joined. Ed told us the story of the Club president at the time who owed the Club a lot of money. So a bunch of members went to the President's house, 'captured' his 1947 Ford, and sold it to pay back the Club treasury. Early on, the Club met at a Savings & Loan building in Reseda. Ed remembers when actor Jerry Lewis had his fund-raising telethon in the same meeting room. So the Valley V-8'ers were pre-empted to another room during the telethon. Finally, Ed had the distinction of being one of the Club's early presidents, year 1975. Jerry Jensen was up next. It started with a '39 convertible sedan he bought from a guy in Ventura. The body was on the frame, but that was about it. The doors were hanging off the garage rafters, other parts were scattered about, so he knew he'd need help in getting the '39 back together. He saw an ad for the V-8 Club in the local green sheet, so joined club for help on his '39. Jerry recalls Club member Jack Miles as being his mentor. Jack was a very knowledgeable, Ford mechanic. When Jerry first joined, Don Durkee was president and Ed Warnock was Vice President. Jerry was working for the fire department when he joined, and when he retired he became President of the Club for two years, 1989 and 1990. Ernie Bailey was our next speaker: He joined a year before he got married, in April of 1976. Ernie mentioned the camaraderie he experienced in the V-8 Club. It reminded him of close friendships he had in his homeland of West Iowa. He especially admired and appreciated Don Durkee. Ernie's Dad was a car guy, and together they found a '47 Ford, bought it for \$75, and dragged it home three blocks, literally. Ernie says they were lucky to make it. Turns out there was only one U-bolt holding the rear end in! When they got it home, his dad told Ernie they had 6 months to get it running. Together they went to a wrecking yard, bought a '65 Ford 289 engine, shoehorned it into the '47, and got it running. It turned out to be a great father-in-son project. Ernie also had a nifty '46 Ford 4-door sedan with a 6 cylinder. In addition to other Club leadership roles, Ernie took his turn as co-editor of the Club Newsletter with Ed Rose, and also served as Club historian for awhile. Chip Werstein was our last speaker. Chip was also one of our past president's, serving in year 1977. Now Chip's dad was a car collector, and prior to Chip getting out of college, his dad decided he should have a car to restore: So a '37 Ford Phaeton was purchased, and became sort of a father-and-son project. This led to Chip joining the Valley V-8s in July, 1973. Don Durkee was president at the time. Chip mentioned a nice feature of the Savings & Loan meeting location: They met in an upstairs room overlooking the parking lot, so one could see all the old Fords parked down below, how swell is that! Chip, and many of our other speakers, recalled that in the early Club days, there were lots of road tours, including the Gamble House in Pasadena and Beverly Hills Car Club, to name a few. The years went by, and sometime in 1984, Chip drove the '37 Phaeton to San Diego, blew the clutch, towed it home, and parked it. Right around that time, an interest in Corvettes took priority, so for Chip the V-8 Club was temporarily on hold. Time marched on, and more recently, his interest in old Ford's has returned. Turns out that his family has been asking him to get the old '37 Phaeton running again, yep, it's been sitting with that blown clutch since 1984! So Chip's back with us again, and he'll have the Phaeton running in no time. Finally, Chip mentioned something that really exemplifies the Club's camaraderie: A long time ago, the Club was at a car show, and Ed Warnock had to leave early. So he let Chip drive his beautiful black '39 Ford convertible home. Ed's generosity left quite an impression on Chip. He knew beyond a doubt that he was in a club where he was trusted and really belonged, way to go, Ed! In summary, the members had and still do have grease under their fingernails, many in the Club drive their cars while they work on them. Yes, situations have changed, but we're still the same car-people, it's just a few year later. Thanks, fellows, for sharing about our rich heritage as a Club and about the individuals, including yourselves, who make up who we are.

**Raffle:** Handled by Steve Boskovich. Many winners took home some fine prizes. As always, thanks, Steve for handling the Raffle.  
**Vasken:** Reminded us of the next Club meeting date, Tuesday Oct. 2. Remember, it's Club Auction night, our once-a-year Auction fundraiser. Invite your friends, and drive home safely.

**8:30 pm: Meeting adjourned.**

Minutes submitted by Rex Jaramillo



---

**William R. Woods Has passed away He was 94.**

There will be Memorial Service on

Friday, October 12th at Descanso Gardens in La Canada at 1:30 p.m .

His wife, Christine, asked me to get the information to JPL people who might wish to attend this service.

For more on this, please visit our Facebook page or the Valley V8's web site

Thank You

---

Visit our Web Site: [valleyv8s.org](http://valleyv8s.org)

Facebook: [Valleyv8s](https://www.facebook.com/Valleyv8s)

(https://www.facebook.com/groups/579123315803014)

From the ~~President~~... Oop's, Not this time..... FROM THE EDITOR

Our Fearless Leader, Vasken Hagopian, Is on holiday in Costa Rica, But will return for our Oct meeting....

SO.... I will fill this page with tails of the Club tour to the Wonderful California Oil Museum in the Beautiful town of Santa Paula. (Thank you Kenny, Joanne and Scotty)

**Tours** - Ken and Joan Sapper: California Oil Museum Tour will be Friday September 7. Meet at Woodley Park 8:15 am, cruise over as a group, or drive to the Museum on your own. The Museum is located at 1001 E Main St, Santa Paula. There will be two tours, both conducted by knowledgeable docents. The first starts at 10:30 am sharp, the second one at 11:15. Then lunch at Garman's Restaurant & Irish Pub, followed by some swell ice cream at nearby Foster's Freeze, this one established in 1959. Joan said to invite others including our school-age grandkids, it's a great history lesson! For more info or to sign up, contact Joan Sapper (818)326-9685. Ken and Joan will call all on the sign-up sheet to final-confirm attendance.

**For more on This & Pics,  
Please visit our Facebook page**

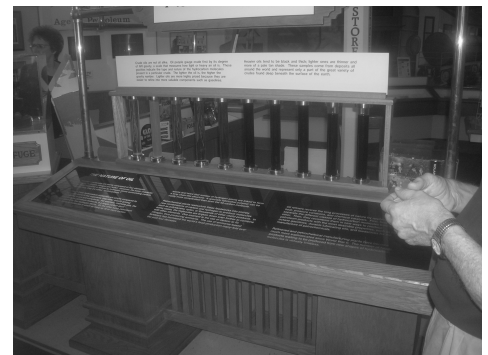

Visit our Web Site: [valleyv8s.org](http://valleyv8s.org)  
Facebook: [Valleyv8s](https://www.facebook.com/groups/579123315803014)  
(<https://www.facebook.com/groups/579123315803014>)



San Fernando Valley V8's  
CHRISTMAS PARTY  
Brunch 10am to 2pm  
Sunday December 2, 2018  
Knollwood Country Club  
12024 Balboa Blvd. Granada Hills



Please return this sheet no later than November 18,  
2018

Make your check payable to "Valley V8's

Mail this sheet with your check to:

Steve Lehman

19535 Vintage St. Northridge, Ca. 91324

Members \$25.00 Per Person

Non Members \$30.00 Per person

Names of Party Goers:

Home Phone:

Amount Enclosed: