

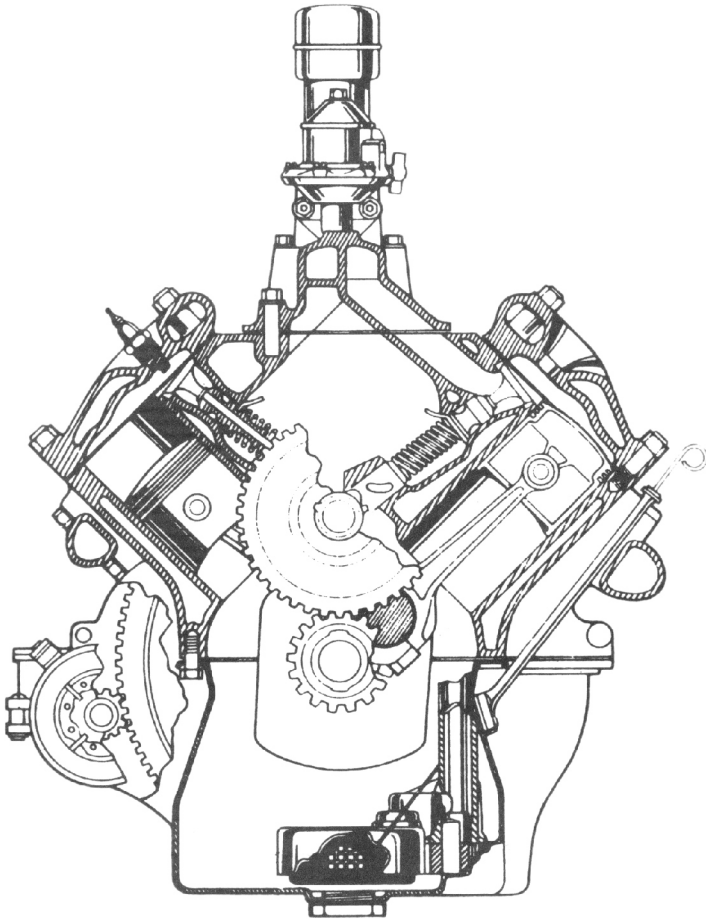

Drive Lines

Chapter #40
Our 47th Year
Visit Our Website
"valleyV8s.org"

Nov 2018



The Valley V8's
9700 Farralone, Chatsworth, Ca. 91311

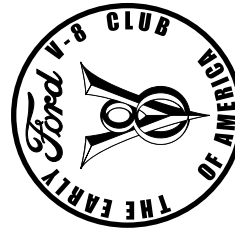

The Valley V8's

2018

President	Vaskin Hagopian	323-661-2044
Past Presidents	Don Durkee	
	Stan Miller	818-360-4812
Vice President	Steve Lehman	818-885-6938
Secretary	Rex Jaramillo	213-706-3854
Treasurer	Joan Sapper	818-249-5686
Tours	Kenney Sapper	818-249-5686
	RichCarter	708-567-2393
Programs	Larry Caplan	818-363-2849
	Joe DiFatta	818-700-1939
Membership	Harry Baker	818-632-9017
	Joan Sapper	818-249-5686
Drive Lines	Robert Glucksman	818-618-1395
	Jim Kelley	310-795-0704
Prize Raffle	Steve Boskovich	818-341-6876
50/50	Ken Sapper	818-380-5686
Ladies / Birthdays / Sunshine	Bobby Searl	818-353-6767
Name Badge	Karen Lehman	818-885-6938
Car of the Month	Jerry Jensen	805-491-3355
Web Master	Scott Dudrick	818-687-9836
Tech. Advisor	John Wolf	818-789-6201

Meeting: 1st Tuesday of the Month, 7:00p
No host Dinner, Starting at 6:00p
Rosie's BBQ & Grill, 8930 Corbin Ave.
Northridge, Ca. 91324

Visit our Web Site: valleyv8s.org

Drive Lines is Published by
The San Fernando V8's Regional Group 40
of the Early Ford V8 Club of America
9700 Farralone, Chatsworth, Ca. 91311

The Valley V8's

Past Presidents

Jim Rowe	1971
Doug Peterson	1972
Don Durkee	1973-1974
Ed Warnock	1975
John Busk	1976
Chip Werstein	1977
Stan Misraje	1978
Bill Culp	1979
Al Spencer	1980
Larry Caplan	1981
Bob Rose	1982
Don Durkee	1983
Paul Kirk	1984
Kent Lowry	1985
Dave Sanborn	1986
John Kemmerer	1987
Dudley Ochsner	1988
Jerry Jensen	1989-1990
Joe DiFatta	1991
Chuck Shubb	1992-1993
George Richards	1994
Jerry Littner	1995
Dick Smith	1996
Chuck Mair	1997
Dennie Keene	1998
Rose Golt	1999
Don Stout	2000
Steve Boskovich	2001-2002
Joe DiFatta	2003
Wendi Potter	2004
Ken Sapper	2005-2006
Stever Batesole	2007
Harry Baker	2008-2009
Dave Bergman	2010
Randy Watson	2011-2012
Steve Boskovich	2013-2014
Stan Miller	2015
Don Durkee	2015
Vasken Hagopian	2016-2018

"Your Ad Here"
For only \$5.00 a month,
YOU
 can have your
 business card ad
 right here

For more details,
Please call or Email Rob at
818-882-2002, / madmodelr@aol.com
Please put "Drivelines" in the subject
Please make all payments to
"Valley V8 Club"

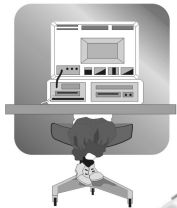

R.H. FACTOR GRAPHICS
Computer Graphics
Desktop Publishing



For all your Pre-Press needs

Robert Glucksman
Chatsworth, Ca. 91311
Office: 818-882-2002
Cell: 818-618-1395
madmodelr@aol.com

Hello Fellow Members...
 We would like to know more about You,
 Your Car...
 So, What I would like from our members is
 a picture of you with your car, with a small
 story. (1 Paragraph)
 That way, We get to learn more about our
 members, & we can put a face to a name &
 car

Please make all submissions to ether
 "Drivelines" at madmodelr@aol.com, or
 "Drivelines" 9700 Farralone Ave.
 Chatsworth, Ca. 91311
Thank You
 Rob Glucksman, DL Editor

SAN FERNANDO VALLEY V8's

CHRISTMAS PARTY

Brunch 10a.m. to 2 p.m.

SUNDAY DECEMBER 2, 2018

KNOLLWOOD COUNTRY CLUB
12024 BALBOA BLVD. GRANADA HILLS



PLEASE RETURN THIS SHEET NO LATER THAN NOVEMBER 18, 2018
 MAKE YOUR CHECK PAYABLE TO VALLEY V8'S
 MAIL THIS SHEET WITH YOUR CHECK TO:

STEVE LEHMAN
 19535 VINTAGE ST. NORTHRIDGE, CA. 91324

MEMBERS \$25.00 PER PERSON
NON-MEMBERS \$30.00 PER PERSON

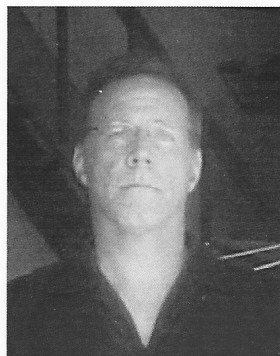

ARBONNE.
 INDEPENDENT
 CONSULTANT

Steven Lehman
 Arbonne Independent Consultant
 Consultant
 23592171

Reset, Restore, Rebalance
 Discover Ultimate Health,
 C 818.517.1268

ArbonneForever@yahoo.com
 www.stevenlehman.arbonne.com

SPEEDWAY
ENGINEERING



Ken Sapper
 President
 ken@1speedway.com
 Office: 818.362.5865
 Cell: 818.326.1286
 Fax: 818.362.5608
 13040 Bradley Avenue
 Sylmar, CA. 91342
 www.1speedway.com

Case Hardened by Jerry Case

Most of the senior members know this about me, I grew up with music, and was playing professionally at age 11.

However also had a burning desire to know about things mechanical, including cars, radios, T.Vs etc. Fast forward to age 75.

Those things are still in my life. In my early days of music (early 60s) I was traveling up and down Route 66 on a regular basis with bands. when it was mostly 2 lane, going thru all the small towns, in 50s or early 60s cars or Vans and even Buses .

So I watched it transcend into I-40.. Anyway almost every year I am part of a music festival in a town close to Austin, so this year I decided to drive the delivery thru all those old towns (Bucket list thing I guess). 3800 miles, never skipped a beat. I had a great time, lot of photo's taken of it, The most common question I was asked, what kind of running gear, I would reply, stock flathead, usually could just not hardly believe it, Jerry



Car of the Month: Handled by President Vasken, won by Joe DiFatta and his nice, we're talking very righteous here, 1946 Ford Deluxe Tudor Sedan. Model year 1946 was the first year back for post-war Fords. In February of 1942 Henry Ford, a known pacifist, was mandated by the U.S. government War Production Board under President Roosevelt, to stop building cars and trucks and support the War effort. So Ford factories began producing airplanes)B-24 Liberator(, military gliders, jeeps, armored cars, engines, generators and so forth, to support the U. S. and the Allies. At the end of the War, the public was eager to purchase new cars. And the 1946 Ford didn't disappoint. The new V-8 equipped Fords were up 15 horsepower over pre-war Fords. Reason: The pre-war Mercury's engine was applied to the 1946 Fords. We're talking 239 cubic inches and 100 horsepower. So Joe's fine Ford packs a punch over pre-war Fords. A little background on his car: He bought it in 1994 from a widow living in Burbank whose husband had lovingly restored it from the ground up. Joe has a photo album of the whole process, including the bodywork and the block sanding to perfection before that beautiful black lacquer was applied. Then a stock tan mohair interior was installed, making this '46 is one fine ride, yep it sure caught Joe's attention! The engine and transmission had also been rebuilt by the same Burbank gentleman who restored the car. After Joe took possession of it, fellow Club member Jerry Case helped him install a Columbia rear end. So that sweet 59AB mill just RPM-loafs at freeway speed, with those dual 28-inch glass packs lending a nice rumble as well. And to cap it off, the radio, heater, and clock all work, what a car! Congratulations, Joe, for October Car of the Month, well deserved!



And now for some "Pressing" News

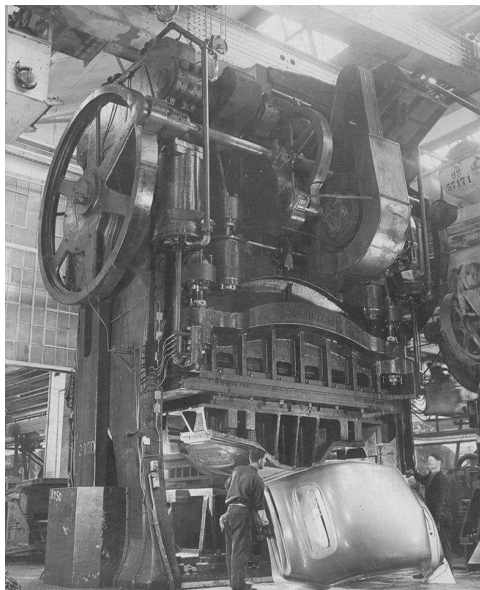

NEW MEMBERS

*The Oct 2nd meeting has brought our FORD V8 family
Mr Howard Brown
He is an avid "Studebaker" Collector,
HOWEVER.....He now owns a Ford
For more about Howard & his Ford, Please read his story
"I Found a Ford"
Welcome to the Club*



I found a Ford!! by *Howard Brown*

About the middle of July, a friend mentioned to me that she had a bunch of 'old cars' she wanted to sell and she asked for my assistance. I questioned her as to what make of cars and she said "mostly Chevys". I then asked her what year, and she said "mostly 57's". I followed up with "what model" and she said "mostly convertibles". At this point I asked "what does MOSTLY mean" and she said "Oh about 20". We made arrangements for a friend and me to go see the cars and take some pictures. When we arrived, we were amazed to see a row of 15 or so '57 Chevy convertibles (covered) in a 45' x '90' building. There were also a few other interesting cars; a 1947 Volvo, a '59 Cadillac convertible, a 66 Avanti II, and a few more. As we looked at the Avanti II, her husband said to me, "if I had to choose which of these cars I'd like to see running first, it would be the Avanti II". I told him I could probably help him with that. Then, the wife said to me, 'now we need to look at the HULK HEAP. I asked what that meant and she said these were vehicles (cars, trucks, trailers, etc.) that she had purchased for parts and when one of the 'good' cars needed something, they simply came to the HULK HEAP and took it off of one of the hulks. These were REALLY derelicts (missing doors, fenders, engines, interiors, etc.) but across the heap of hulks, I spotted one that didn't look nearly like the others. Upon a little closer inspection I determined that it was a 1955 Ford Fairlane Crown Victoria and that despite resting on flat tires and being sunken almost down to the frame in the dirt, it looked to be a rough but complete car. I asked if it was for sale and she said yes. I then asked if we could work out some arrangement where I could get the Avanti II running in return for partial payment for the Ford. She told me that I could have the Ford if I could get the Avanti II running.

I have 'retrieved' the Ford and brought it to my house and the Avanti II runs. I have cleaned up the Ford and found that it is actually in better condition than I thought. Keep in mind that despite the fact that the Ford was sitting outside (probably for 20 years), this is really one of those 'barn finds' that everybody hears about but never finds.

I'm presently waiting for a title from the DMV (the original was lost after all those years) and then I'll start working on the Ford in earnest.



Chapter 40 -- San Fernando Valley V-8's Club

Monthly Meeting Minutes for Tuesday Oct. 2, 2018

7:00 pm: Meeting called to order

President Vasken Hagopian opened the meeting, welcomed the group, led us in the Pledge of Allegiance.

Guest Introductions, other comments:

Welcome guests/new members: Scott Cramolini introduced guests Dennis Maddox and Brian Cole. Dennis is presently buying a '36 Ford convertible sedan, and Brian is looking for a '42 1/2ton truck. Also present again was 1977 past-president Chip Werstein. Remember his 1937 Ford Phaeton project from last month, great story! Robert Glucksman then introduced new member Howard Brown, proud owner of a '55 Ford Victoria.

Club Barbecue: Steve Boskovich gave a report on the barbecue held last Sunday. Steve thanked those who attended, there were over fifty people present, and thanked all who helped set up, and those who cleaned up afterward.

Christmas Party update: Steve Lehman reports that only three people have signed up to-date. He needs sign ups for head-count, etc. Send a check to Steve right away or give him a check tonight. You'll find the Christmas Party applications on the last page of the latest Club Driveline September Newsletter.

Coffee'n Kix with Don: The last 'Kix for the season will be this Saturday October 6. The theme: 'New' old cars(that haven't been at 'Kix before. Here's an opportunity to pull that old Ford out of the woodwork and gas, grease, wax, then cruise it to 'Kix!

Voting: Don't forget to vote. Next meeting is November 6, same date as voting day. Busy day, you can do it!

Nice flathead for bid: Steve: Bokovich talked about the engine sitting in the back of his truck: It's a complete '49-53 Ford V-8 engine, guaranteed not to be cracked. It will be auctioned tonight.

Happy Columbus Day next Monday.

Happy Halloween coming up, end-of-month.

Costa Rica report: President Vasken and wife Evie returned from their time in Costa Rica. And it was an adventure! They went through two earthquakes, three active volcanoes erupting, and one national strike. Traffic was a challenge, drivers are still 'terrible', as stated by Vasken. Apparently they don't adhere to traffic laws like they should, motorcyclists being the worst. There are five motorcycle deaths every day. And if you're a pedestrian there, in Vasken's words, forget it! The rain was unbelievable. 20 out of 28 days they were there, it rained! Annual rainfall in that country is 160 inches a year. Getting gas for his car is among Vasken's favorite activities. Reason: All gas stations are full-serve. And at Vasken's favorite gas station, the female attendants usually wear bikini's, However, this year they were mostly covered up because of the rain. And the rain also delays airplane flights. Their flights into and out of Costa Rica were delayed because of rain. But they made it back. And Vasken promised he'd charge his electric razor.

(Monthly Meeting Minutes Continued)

Reports from Officers:

Secretary Rex Jaramillo: Everything OK.

Treasurer -- Joan Sapper: Everything OK. Joan gave a Club financial report. She encouraged us to buy big tonight and help support the club's treasury.

Tours Ken Sapper: Ken gave a report on the California Oil Museum Tour held on Friday September 7. There were 22 participants who arrived at 10:30 am sharp. Some met earlier at Woodley Park, and drove their fine old Fords, rolling together, what a sight, very capably led by Joan and Ken Sapper through that very scenic Pass, Grimes Canyon Road. The Fords ran great, no breakdowns, overheats, or flats, what a drive! Once at the Museum, there were two docents who gave a great tour and shared some amazing history. The Museum has been restored and most of the furniture and memorabilia is still in place and intact. And the land nearby is still oil-rich. The black smudges seen from afar on the surrounding hills is oil seeping out of the ground, especially visible now because of the fire burn-off. After the tour, it was off to Garman's Restaurant & Irish Pub for a superb lunch. After lunch, the 'frosting on the cake' was nearby Foster's Freeze. In all, a most excellent Tour, thanks Ken & Joan Sapper, also Scott Cramolini, for setting it up.

Drive Lines Editor -- Robert Glucksman: Everything OK.

Membership/Club Directory Jerry Littner, all OK.

7:20 pm: Break called 7:45 pm: Meeting resumed

Car of the Month: Handled by President Vasken, won by Joe DiFatta and his nice, we're talking very righteous here, 1946 Ford Deluxe Tudor Sedan.

50/50 Drawing: Handled by Ken Sapper, won by new member Howard Brown.

Program: After the break, our Auction commenced, capably conducted by the competent crew of Joe DiFatta, Steve Boskovich, and Scott Cramolini. As usual, it was very entertaining with a great selection of items brought in by generous Club members, Thanks all who brought items, and thanks to Joe, Steve, and Scott for a job well done.

Vasken -- Closing Comments: Next meeting Nov. 6. Don't forget to vote.

8:55 pm: Meeting adjourned



November Speaker



At our next meeting Scott Doudrick, our resident NASA engineer, will talk about the latest news at the Jet Propulsion Laboratory. This will include the current state of our Mars Rovers and our soon to be newest member of the Mars family, Insight, due to land on November 26. One of the Rovers, Curiosity, recently discovered a large amount of organic molecules as well as variable methane in the atmosphere – both important indicators of potential past or present life. He will also talk about the final days of the Cassini spacecraft before it was purposefully de-orbited into Saturn as it had run out of fuel. Scott's presentations always have lots of great pictures of space so join us to see them for yourself.

From The President.

Happy Thanksgiving

November fourth, set your clocks back.
November 6th is Election Day.
November 11th is Veterans Day.
November 22nd is Thanksgiving.



Where did the year go?

It is good to be back to paradise (Los Angeles). It rained 20 out of the 28 days in Costa Rica. 3 days of rain there, is equivalent to our season. Two earthquakes, 3 active volcanos, the country is on strike, and the gasoline is \$5.50 a gallon. But we had fun.

I welcome all our new members.

The auction was very successful, this is our largest fund raiser for our club. As you see our treasury balance is very low, and our Christmas brunch will have a big expense. Remember that it costs you \$25 for your ticket, and the club pays the difference of the actual cost for each member.

It is that time of the year for our members to step up and take a position in our Board Of Directors, there are many positions on the board, it is easy, and fun.

Please sign up and pay for your Christmas Brunch at the Knollwood Country Club on December 2nd. We need head count to order the food. Please bring a check or cash to our next meeting, and pay Steve Lehman for the brunch. \$25 for the members, and \$30 for the guests. November 18 is the cut off date, then you are too late to enjoy this beautiful Christmas celebration with the rest of our members.

The Christmas Brunch flyer is the Drive Line.

Thank you Board of Directors for making our club shine.



Please bring a friend to our meeting.

Happy Thanksgiving



Vasken Hagopian

