

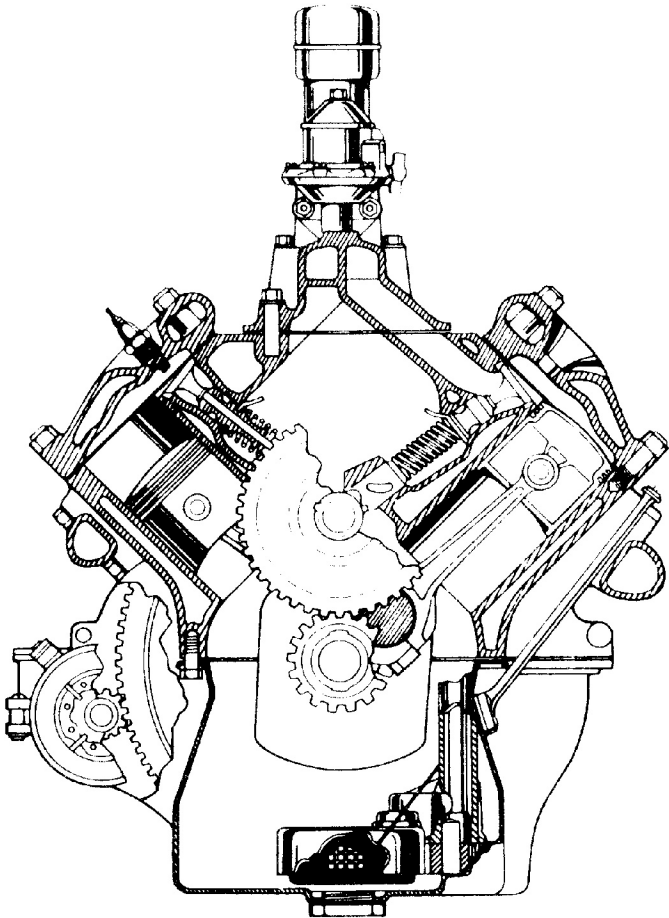

# Drive Lines

Chapter #40  
Our 47th Year  
Visit Our Website  
"valleyV8s.org"

Dec 2018



The Valley V8's  
9700 Farralone, Chatsworth, Ca. 91311

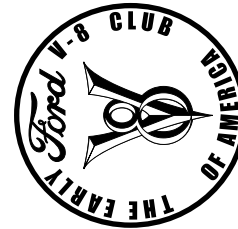

# The Valley V's

## 2018 / 19

President	Ernie Baily	805-428-0558
Past Presidents	Vaskin Hagopian	323-661-2044
	Don Durkee	
Vice President	Jim Ellerbrock	818-437-0412
Secretary	Rex Jaramillo	213-706-3854
Treasurer	Joan Sapper	818-249-5686
Tours	Kenney Sapper	818-249-5686
	Rich Carter	708-567-2393
Programs	Larry Caplan	818-363-2849
	Joe DiFatta	818-700-1939
Membership	Sandrine Cutright	310-804-7790
	Oliver Calibet	818-310-8571
	Joan Sapper	818-249-5686
Drive Lines	Robert Glucksman	818-618-1395
Prize Raffle	Steve Boskovich	818-341-6876
50/50	Ken Sapper	818-380-5686
Ladies / Birthdays / Sunshine	Bobby Searl	818-353-6767
Name Badge	Karen Lehman	818-885-6938
Car of the Month	Jerry Jensen	805-491-3355
Web Master	Scott Dudrick	818-687-9836
Tech. Advisor	John Wolf	818-789-6201

Meeting: 1st Tuesday of the Month, 7:00p  
 No host Dinner, Starting at 6:00p  
 Rosie's BBQ & Grill, 8930 Corbin Ave.  
 Northridge, Ca. 91324

Visit our Web Site: [valleyv8s.org](http://valleyv8s.org)

Facebook: **Valleyv8s**

(<https://www.facebook.com/groups/579123315803014>)

Drive Lines is Published by

The San Fernando V8's Regional Group 40  
 of the Early Ford V8 Club of America  
 9700 Farralone, Chatsworth, Ca. 91311

# The Valley V's

## Past Presidents

Jim Rowe	1971
Doug Peterson	1972
Don Durkee	1973-1974
Ed Warnock	1975
John Busk	1976
Chip Werstein	1977
Stan Misraje	1978
Bill Culp	1979
Al Spencer	1980
Larry Caplan	1981
Bob Rose	1982
Don Durkee	1983
Paul Kirk	1984
Kent Lowry	1985
Dave Sanborn	1986
John Kemmerer	1987
Dudley Ochsner	1988
Jerry Jensen	1989-1990
Joe DiFatta	1991
Chuck Shubb	1992-1993
George Richards	1994
Jerry Littner	1995
Dick Smith	1996
Chuck Mair	1997
Dennis Keene	1998
Rose Golt	1999
Don Stout	2000
Steve Boskovich	2001-2002
Joe DiFatta	2003
Wendi Potter	2004
Ken Sapper	2005-2006
Steven Batesole	2007
Harry Baker	2008-2009
Dave Bergman	2010
Randy Watson	2011-2012
Steve Boskovich	2013-2014
Stan Miller	2015
Don Durkee	2015
Vasken Hagopian	2016-2018
Ernie Baily	2019-????

**"Your Ad Here"**  
*For only \$5.00 a month,*  
**YOU**

can have your  
business card ad  
right here

**For more details,**  
Please call or Email Rob at  
**818-882-2002, / madmodelr@aol.com**  
Please put "Drivelines" in the subject  
Please make all payments to  
**"Valley V8 Club"**



## HELLO FELLOW MEMBERS

We would like to know more about You,  
Your Car...

So, What I would like from our members is  
a picture of you with your car, with a small  
story. (1 Paragraph)

That way, We get to learn more about our  
members, & we can put a face to a name &  
car

Please make all submissions to ether  
"Drivelines" at [madmodelr@aol.com](mailto:madmodelr@aol.com), or  
"Drivelines" 9700 Farralone Ave.

Chatsworth, Ca. 91311

*Thank You*

Rob Glucksman, DL Editor

---

## January Speaker

Jim Diamond will speak about the history of  
"JEEPS"

Jim has been & still an owner of the Bantam  
Jeeps. He will of course tell us of the Ford jeep  
history

Bring a friend

This is the way to start the New Year



## R.H. FACTOR GRAPHICS

**Computer Graphics  
Desktop Publishing**

**Robert Glucksman**  
Chatsworth, Ca. 91311  
Office: 818-882-2002  
Cell: 818-618-1395  
[madmodelr@aol.com](mailto:madmodelr@aol.com)



ARBONNE.  
INDEPENDENT  
CONSULTANT

**Steven Lehman**  
Arbonne Independent Consultant  
Consultant  
23592171

Reset, Restore, Rebalance  
Discover Ultimate Health,  
C 818.517.1268

[ArbonneForever@yahoo.com](mailto:ArbonneForever@yahoo.com)  
[www.stevenlehman.arbonne.com](http://www.stevenlehman.arbonne.com)

## SPEEDWAY ENGINEERING



**Ken Sapper**  
President

[ken@1speedway.com](mailto:ken@1speedway.com)  
Office: 818.362.5865  
Cell: 818.326.1286  
Fax: 818.362.5608  
13040 Bradley Avenue  
Sylmar, CA. 91342  
[www.1speedway.com](http://www.1speedway.com)

***Car of the Month:*** Handled by Jerry Jensen, honors for November went to that oh, so swell, '51 Ford convertible owned by Harvey Jacobs. Covered in medium metallic blue and dressed in white tuck & roll, this is one fine Ford! While young Harvey was in high school, he had a '51 Ford. He sold it, the years went by, and, you know how it is, with good memories of his first '51 still playing in his mind, Harvey just had to have another one. Now the 'new' '51 Ford that Harvey found was a very desirable California-build car, originally came out of the Ford assembly plant in Long Beach, CA. This particular assembly plant was built in 1930 to expand production of the Model A. So new Fords rolled out until late 1958 when the plant was closed because of unstable ground caused by nearby oil drilling, whew! Anyway, Harvey's '51 was sold, re-sold, spent some time out of state for awhile, but meandered back to it's roots in California, ending up with a broker in Palm Desert. That's where Harvey found and purchased this gem. It was looking mighty fine when he bought it, pretty much the same as you see it here, but it needed some sorting out mechanically. So Harvey rolled up his sleeves, and rebuilt/refurbished the suspension and brakes for safety, and sealed up some pesky oil leaks. The engine is the original 8BA flathead, pretty much stock except for dual exhausts and a four barrel carburetor. So this Ford pulls nicely, and when Harvey kicks it into overdrive, she loafs down the highway. Congratulations, Harvey for Car of the Month, November, well deserved!



---

## Parting Words

*From the Former President  
Happy New Year*

*I wanted to thank you for allowing me to serve as your President for 2016 - 2018.  
I was proud to serve, and help the club.*

*Some of you do not come to the meetings, due to health reasons. This is for you as you  
read the DriveLine.*

*Thank You, Get well, Prayers do work, and God Bless You  
Happy New Year*

*Vasken Hagopian*

---

We received a nice "Thank You" note from "Loaves & Fishes" Thanking our club members for their donations of toys for needy children  
Joe DiFatta

*And now for some  
"Pressing" News*

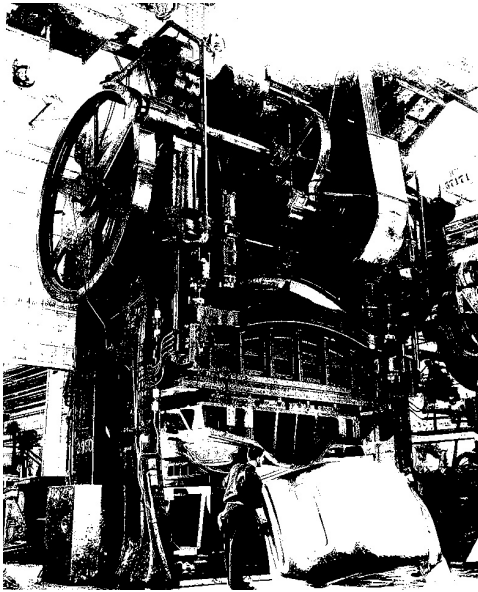

**NEW MEMBERS**

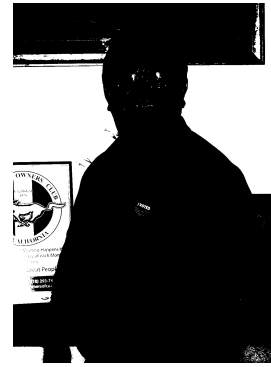

Mike Quiroga

Mike is a proud owner of a  
1948 Ford Delux, 4d Sedan  
1959 Ford Fairlane, 2d Sedan  
1965 Ford Mustang HT  
Welcome to the Club, Mike



**From the Editors desk....**

Well, Another year has passed, (1 down, 3 more to go as Editor)  
I think it's been a good one, with some up's & downs. We've lost some members, & we've gained some members.

The end of this year has, to say the least, been problematic. Fire Storms. To the best of My knowledge, All that got evacuated are back & safe in their homes  
A side from the obvious loss of homes, there were many classic cars destroyed.. NOT to take away from the loss of life & homes, as they say, One mans trash is another mans treasure... After our Family & homes, our cars are our treasurers, & part of history, OURS

I / We have seen the loss of a piece of history, One of the oldest model companies closed, Revel / Monogram. I know that I started building with My parents, which led to My love of cars. I also build with My kids, as I'm sure many of you did. Maybe you started with Slot Cars. What ever it was, I bet, somewhere there are small scale in the beginning...

NOW, as the year 2018 comes to a fast close, We will say good bye to some board members & Welcome to some New ones, +++ Also, we have new members.  
I for one, Love this group. There is so much history of Members, & so many are willing to help each other

In Closing, Thank ALL of You. You have embraced My work on the DriveLine, I look forward to 2019, the tours, Meetings, & the rest of what this great group of People bring & share

Thank You  
Robert, Drive Line Editor

## Chapter 40 -- San Fernando Valley V-8's Club

### Monthly Meeting Minutes for Tuesday Nov. 6, 2018

#### **7:00 pm: Meeting called to order**

President Vasken Hagopian opened the meeting, welcomed the group, led us in the Pledge of Allegiance.

#### **Guest Introductions, other comments:**

Welcome new members/guests: We have a new member: Mike Quiroga, who owns a "48" Ford. Welcome aboard, Mike! And Al Mooney introduced his guest, son Brian Mooney. Brian was our guest speaker last year, welcome back, Brian! Also, Sandy Dingman was present as a guest of her dad, Jim Kelley. Remember her swell Metropolitan?

#### **Announcements:**

An opportunity to provide Christmas joy: Steve Boskovich mentioned our ongoing opportunity to support Haven Hills, which is a shelter for women and families suffering from domestic violence. When you travel and go to a hotel, be sure and gather up the extra soap, shampoo, and lotions that are provided, bring them to our Club meeting, and they will be forwarded to Haven Hills. Also, for the Christmas Brunch, bring an unwrapped gift for a child, also an unwrapped gift for a mother. The items we provide allow kids and mothers to wrap and give each other gifts for Christmas. What better way to celebrate the Season than to participate in this joyful activity. Brake work needed: If anyone knows someone who works on old Ford brakes, see Mike Quiroga, our new member.

**New Board Members:** Vasken announced our new officers for the upcoming year. Starting at the top, Ernie Bailey will be our new President. Jim Ellerbrock will be our new Vice President. Oliver Calibet and Sandrine Cutright will be our new Membership/Directory officers. All the rest of the Board positions will remain the same.

**Veteran's Day, Sunday November 11:** Vasken honored the Military Veterans in our Group, those of us that had the privilege of serving, stood up. Then Vasken shared photos of his days in the Army from Fort Ord, also showed us his GI-issue tin cup. Then Joe DiFatta related how, on the way to boot camp, he almost hopped off the train as it headed through San Fernando and home. He got through it, though.

**Christmas Brunch:** Steve Lehman announced that we're still short by 25 people for a full head count. Otherwise the Club would have to make up the \$ difference. He requested that all who plan on going to the Brunch please sign up tonight so he can provide a final head count. If you still need to sign up, please call Steve Lehman (818)885-6938.

#### **Reports from Officers:**

**Secretary** - Rex Jaramillo: Everything OK.

**Treasurer** - Joan Sapper: Everything OK. Joan gave a Club financial report.

**Tours** - Ken Sapper: We will have some great activities for next year, stay tuned.

**Drive Lines Editor** - Robert Glucksman: Everything OK.

**Membership/Club Directory** - Jerry Littner, all OK.

#### **Upcoming Car Shows** - Vasken announced:

November: 11: / Long Beach High Performance Swap Meet, Veteran's Stadium, Long Beach. /16: Orphan's Car Show Auto Driving Museum. /17: In & Out Burger & Hot Rods 70th Anniversary Celebration and Drags, Auto Club Raceway, Pomona.

December 2: / Our Club's Christmas brunch, 10 am Knollwood Country Club, Granada Hills. / 9: Long Beach High Performance Swap meet. / 30: L.A. Auto Show, Convention Center, downtown

**NOTE:** No Club meeting for December. / Tuesday Jan 8, 2019 will be our next meeting.

#### **7:28 pm: Break called 7:50 pm: Meeting resumed**

**Car of the Month:** Handled by Jerry Jensen, honors for November went to that oh, so swell, '51 Ford convertible owned by Harvey Jacobs.

**Lady's raffle:** Handled by Bobbie Searl, won by landscape artists Sandrine Cutright and Sandy Dingman.

(Monthly Meeting Minutes Continued)

**Birthdays for October, November, & December:** Handled by Bobby Searl: The following happy celebraters were recognized: **October:** David Sanborn-3. Kim Ofria-5. Dave Bergman-11. Richard Mottern-15. Mary Zecher-27. Ann Marie Batesol-29. **November:** Doug Schnetlage-1. Marie Miller-1. Joan Sapper-9. Evelyn Hagopian-14. Robert Zecher-19. Kathy Piscopo-21. Ernest Baily-25  
**December:** Ron Batesole-8. Ken Sapper-15. Jim Dawson-30.

**50/50 Drawing:** Handled by Ken Sapper, won by Vasken, not rigged.

**Program:** Our speaker for the evening was our very own Scott Doudrick. Scott is owner of a '39 Ford pickup, and is the 'webmaster' for our Club's Facebook page. And, best of all, Scott has the most interesting job in the world. He works at NASA JPL, or Jet Propulsion Laboratory, how swell is that! Armed with a great PowerPoint presentation, Scott talked about JPL's planetary exploration missions, more specifically the planet Mars research program and exploratory 'rover' vehicles on the Planet Mars surface. The first rover was Sojourner, which landed on Mars on July 4, 1997. To date, there have been four rover vehicles placed on the surface of Mars. Each vehicle takes 7 to 11 months of travel time to reach Mars. These vehicles explore the Mars planet surface, sending photos and data back to earth for analysis.  
Some Rover updates: Scott gave us some updates, starting with Opportunity, one of the early Mars rovers with an interesting twist Rover 'Opportunity' landed on Mars in 2004 and was only expected to last 90 days because of harsh surface conditions. However, it was still going strong until June, 2018, amazing! Since then, despite commands to communicate, no signal has been heard. Opportunity likely experienced a low-power fault, possibly solar panels inoperative because of dust storm, stay tuned, time will tell! Speaking of dust storms, Scott showed us some time-lapse slides of afore mentioned. Now Scott also mentioned that conditions on Mars surface are harsh, testing the rovers to their limits, and dust storms is one of their challenges, both for visual photography and for proper rover operation. And because it takes around 10 minutes for light or radio waves to travel to and from Mars, it can be a little tricky when technicians maneuver the rovers on the Mars Planet surface.

Is there life out there? Of particular interest is the discovery of methane gas molecules by Rover Curiosity. Methane gas typically comes from living organisms. And meteorites from Mars have been analyzed and found to contain organic material, how interesting is that!

Cassini's last gasp: Scott mentioned another spacecraft that is a cult hero in the space industry. Cassini was launched in October, 1997 and sent to Saturn. It took 7 years to reach Saturn, traveling 2 billion miles in the process. Its purpose was to explore Saturn, it's rings, and its moons. Years later, after countless orbits around Saturn, discovering new moons, sending valuable photos and data to earth, Cassini ran out of fuel and in September, 2017, finally plunged through Saturn's atmosphere at 76,000 mph until it burned up.

What's next from JPL? Scott mentioned the next rover 'Insight', which will be landing on Planet Mars on November 26. Interesting point here, the landing of Insight will be viewable on NASA TV, so stay tuned! What a great presentation, thanks, Scott for sharing this oh so interesting information, good job!

**Raffle:** Handled by Steve Boskovich: Many gifts were won by some very happy people, thanks, Steve for running the raffle.

**Vasken -- Closing Comments:** There will be no Club meeting in December, instead, we'll have our Club Christmas brunch held at 10 am on Sunday December 2. Next 'official' club meeting will be Tuesday January 8. We're skipping the first Tuesday of the new year because it falls on January 1. Happy Thanksgiving, and drive home safely.

**8:39 pm: Meeting adjourned**

Minutes submitted by Rex Jaramillo

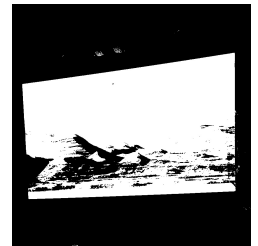
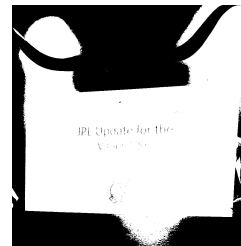
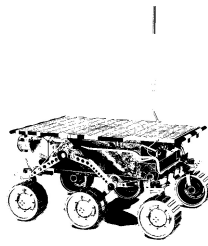

Merry Christmas, Happy New Year, and Happy Hanukkah.

It was an honor to serve you as your president for the last three consecutive years. I have always said that this is the best club out of the other clubs that I belong. What makes this club the best are the members. It is you, the member that are warm, friendly, active, caring for each other, and a great board of directors that work so hard to make this club shine.

Thank you Don Zabel and Kenny Sapper for encouraging me to join the Valley V8 Club. Sorry Joe Difatta, you came so close for your "four more years".

Our new president is Earnie Baily. A long time member of our club, one of the nicest guys around, he will do a great job as our president.

Jim Elenbrock is our new V.P. Oliver Caliber and Sandrine Cutright volunteered for the membership.

These three newest members just stepped up to help our club. (Hint, hint).

Please look inside our Valley V8 Directory, and study the former presidents of our club, the Board Of Directors, the members, names, spouses,, cars, etc. a lot of work goes in the book, and thank Jerry Littner for his contribution for the directory.

We have a new (almost New) p.a. system, thanks to Blake Wilcox. He deals with sound systems for the studios.

Our old p.a. has some bad pistons, and some bad valves. (Rest in peace in p.a. junk yard)

We have to work on raising our treasury balance, it is on the low side. Our auction and the membership dues are our only income, besides the 50/50 and the raffle.

Please bring your ideas/suggestions to our next meeting, and see how we can help our club.

Now I can sit and enjoy a hot dinner, and mingle with the members, my friends.

Thank you again for allowing me to be you president.

Merry Christmas, Happy New Year, and Happy Hanukkah.

Vasken Hagopian



Earnie  
Baily

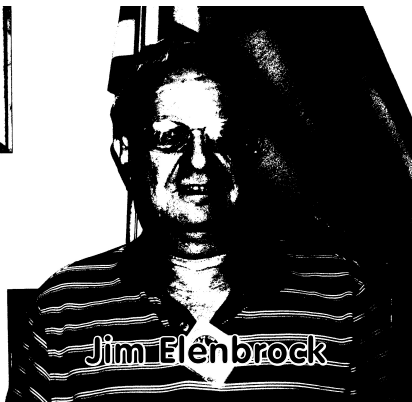

Jim Elenbrock



Oliver Caliber  
Sandrine Cutright







P.O. Box 260  
Canoga Park, CA 91305

Office: 818.887.7481  
Fax: 818.887.4796  
Crisis Line: 818.887.6589

[www.havenhills.org](http://www.havenhills.org)

December 5, 2018

Steve Boskovich  
Valley Early Ford V-8  
10745 Delco Ave.  
Chatsworth, CA 91311

Dear Steve:

Thank you for your donation of the holiday toys valued at approximately \$1,200. Your gift allows us to remain steadfast in our goal to assist victims of domestic violence and break the cycle of violence that negatively impacts so many lives.

Your generous contribution supports our efforts in providing critical, life-saving and life-changing services. With your help, and ours, we transform and save lives. It is so heartwarming to hear from someone who has been in our shelter, and through counseling and support, is now making a new life for herself and her children.

One survivor wrote...

*"It took time for me to believe in myself. It doesn't happen overnight. At times it felt like forever. But here I am a year without pain. I have so much more than I ever had in my life. I have me back....I will continue my journey as well as my growth. Wherever it leads me, I am ready to take it on."*

You make these transitions possible. With your help and ours, victims of domestic violence will rediscover what it feels like to be safe, and they will find the strength to become strong survivors.

Once again, on behalf of Haven Hills and the families we serve, thank you.

Sincerely,

Iliana G. Tavera  
Executive Director



*Your gift to Haven Hills is tax-deductible to the fullest extent of the law. Haven Hills is a 501(c)3 organization and federal tax ID number is 95-3196247.*

# HAPPY HOLIDAYS

From the *NEW*  
Presidents Message:

Hello V8ers!

I hope everyone had enjoyable and happy holiday and Happy New Year! First off! I want to say, the V8 Xmas Brunch was a lot of fun!. I really liked talking with everyone and the food was very good. I enjoyed the music that Jerry Case and Whitney Rydbeck and Al Mooney provided. Once again, "Thank You" to all of last years officers for a great year and Xmas brunch.

As far as the V8 club goes, I hope along with the help of the board members and all of your help, we'll have a great year. I would like to see more members driving their cars to meetings. Also from the past, a couple of ideas!, the club used to do more driving tours, maybe a club Car Show!. If anyone has any suggestions, please let me and board know! Please come out to the first meeting and watch me stumble through It.

Your New (nervous) President  
Ernie Baily

## Holiday Brunch

Big Success this year at the Valley V-8 Ford Christmas Brunch...

Around 70 people were in attendance. Over 30 raffle prizes were there for the taking -- including a FORD Bar Stool

Tickets this year were sold by Rich Carter.....\$10.00 for a arm length of tickets---(He sure has long arms)

New officers were installed including our new president Ernie Bailey  
Thanks to Vaskin Hapogian for being our President for the past three years AND to the committee for this great brunch See you all --- Jan 8th!!!! Happy New Year's



# The Valley V-8's 2019 Membership Application & Renewal Form

In order to continue to receive the Drivelines and remain in the roster...

Or to join our club...

**Please renew your membership by February 15, 2019**

Name: \_\_\_\_\_ Birthday Month: \_\_\_\_\_ Day: \_\_\_\_\_

Spouse: \_\_\_\_\_ Birthday Month: \_\_\_\_\_ Day: \_\_\_\_\_

Address: \_\_\_\_\_ City: \_\_\_\_\_ State & Zip \_\_\_\_\_

Phones - Home \_\_\_\_\_ Cell \_\_\_\_\_ Work \_\_\_\_\_

Email: \_\_\_\_\_

Occupation: \_\_\_\_\_

Year Joined: \_\_\_\_\_

Early Ford V-8 Vehicle(s) Owned - if same as prior year write "NO CHANGE"

<u>Year</u>	<u>Make</u>	<u>Model</u>	<u>Body Style</u>
_____	_____	_____	_____
_____	_____	_____	_____
_____	_____	_____	_____
_____	_____	_____	_____
_____	_____	_____	_____

**For Regional Membership:** Send a \$35.00 check - payable to: Valley V-8's

**Mail check to:** Valley V8's C/O Oliver Calibet 6732 Gaviota Ave., Lake Balboa, CA 91406

**If you have any questions please call 818-310-8571 Email: [sixty4500@gmail.com](mailto:sixty4500@gmail.com)**

**NOTE:** For us to meet insurance requirements, a Regional Group Member **MUST** also be a member of the Early Ford V-8 Club of America. Minimum membership is \$35.00 per year. Please contact me for mailing information or <http://www.earlyfordv8.org>