

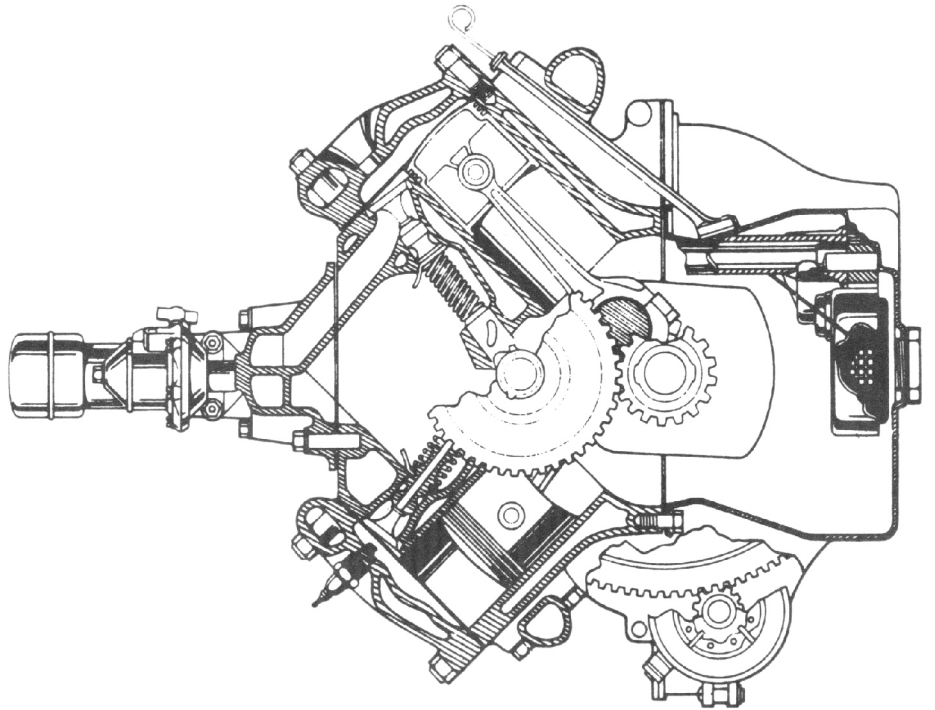

# Drive Lines

*Chapter #40  
Our 49th Year  
Visit Our Website  
"ValleyV8s.org"*

Apr 2020



**The Valley V8's  
9700 Farralone, Chatsworth, Ca. 91311**



# The Valley V8's

## 2020

President	Ernie Baily	805-433-5540
Past Presidents	Vaskin Hagopian	323-661-2044
Vice President	Jim Ellerbrock	818-437-0412
Secretary	Rex Jaramillo	213-706-3854
Treasurer	Joan Sapper	818-249-5686
Tours	Kenney Sapper	818-249-5686
	Rich Carter	708-567-2393
Programs	Larry Caplan	818-363-2849
	Joe DiFatta	818-700-1939
Membership	Howard Brown	818-606-0267
	Joan Sapper	818-249-5686
Drive Lines	Robert Glucksman	818-618-1395
Prize Raffle	Steve Lehman	818-885-6938
50/50	Ken Sapper	818-380-5686
Ladies / Birthdays / Sunshine	Bobby Searl	818-353-6767
Name Badge	Karen Lehman	818-885-6938
Car of the Month	Jim Ellerbrock	818-437-0412
Web Master	Scott Dudrick	818-687-9836
Tech. Advisor	John Wolf	818-789-6201

Meeting: 1st Tuesday of the Month, 7:00p  
 No host Dinner, Starting at 6:00p  
 Rosie's BBQ & Grill, 8930 Corbin Ave.  
 Northridge, Ca. 91324

Visit our Web Site: [valleyv8s.org](http://valleyv8s.org)

Facebook: **Valleyv8s**

(<https://www.facebook.com/groups/579123315803014>)

Drive Lines is Published by  
 The San Fernando V8's Regional Group 40  
 of the Early Ford V8 Club of America  
 9700 Farralone, Chatsworth, Ca. 91311



### Past Presidents

Jim Rowe	1971
Doug Peterson	1972
Don Durkee	1973-1974
Ed Warnock	1975
John Busk	1976
Chip Werstein	1977
Stan Misraje	1978
Bill Culp	1979
Al Spencer	1980
Larry Caplan	1981
Bob Rose	1982
Don Durkee	1983
Paul Kirk	1984
Kent Lowry	1985
Dave Sanborn	1986
John Kemmerer	1987
Dudley Ochsner	1988
Jerry Jensen	1989-1990
Joe DiFatta	1991
Chuck Shubb	1992-1993
George Richards	1994
Jerry Littner	1995
Dick Smith	1996
Chuck Mair	1997
Dennis Keene	1998
Rose Golt	1999
Don Stout	2000
Steve Boskovich	2001-2002
Joe DiFatta	2003
Wendi Potter	2004
Ken Sapper	2005-2006
Steven Batesole	2007
Harry Baker	2008-2009
Dave Bergman	2010
Randy Watson	2011-2012
Steve Boskovich	2013-2014
Stan Miller	2015
Don Durkee	2015
Vasken Hagopian	2016-2018
Ernie Baily	2019-????

## Our Next Meeting

### Tues, 7 Apr 20

# NEXT MEETING???

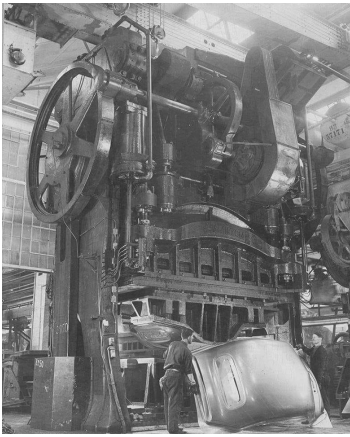

And now for some  
"Pressing" News



**Tickets for Long Beach Grand Prix:**

Bill Green announced that he has  
VIP tickets available for \$300 apiece.  
These include best seats, hospitality tent, and much more.



### Ventura Early Ford V8 Club - 2020 Activity Calendar

**April Meeting - Tues 21<sup>st</sup>**

**EVENT** - Overnight Tour Carmel and Monterey 17 mile drive.

**EVENT** Sunday 26<sup>th</sup> Westlake Village Rotary Street Fair & Classic/Exotic Car Show

**May Meeting Tues 19<sup>th</sup>**

**EVENT** - Regional Chapter Day Drive (SFV, Huntington Beach

**June Meeting Tues 16<sup>th</sup>**

**EVENT** - Sat 20<sup>th</sup> Club Drive and Picnic Sarzotti Park Ojai, wine tasting

Shopping & **Drive Your V8 Ford Day.**

**July Meeting Tues 21<sup>st</sup>**

**EVENT** - Piper J3 Fly-In Lompoc & Mendenhall Museum Buellton

**EVENT** - Sat 25<sup>th</sup> Santa Barbara Woodie Show

**"Your Ad Here"**  
For only \$5.00 a month,  
**YOU**  
can have your  
business card ad  
right here

For more details,  
Please call or Email Rob at  
818-882-2002, / madmodelr@aol.com  
Please put "Drivelines" in the subject  
Please make all payments to  
"Valley V8 Club"



## HELLO FELLOW MEMBERS

We would like to know more about You, Your Car...  
So, What I would like from our members is a picture of you  
with your car, with a small story. (1 Paragraph)  
That way, We get to learn more about our members, & we  
can put a face to a name & car

Please make all submissions to ether  
"Drivelines" at madmodelr@aol.com, or  
"Drivelines" 9700 Farralone Ave. Chatsworth, Ca. 91311

*Thank You*

Rob Glucksman, DL Editor

SOLUTIONS IN PACKAGING AND GRAPHIC DESIGN

**Steve Boskovich**

Office (818) 341-2291  
Cell (818) 903-6620  
Fax (818) 341-1050

P.O. Box 4074  
Chatsworth CA 91313

8744 REMMET AVE.  
CANOGA PARK, CA 91304

(818) 998-0199  
FAX (818) 341-2073

**AL MOONEY**  
C.F.O.

al@mooneyindustries.com

**SPEEDWAY  
ENGINEERING**



**Ken Sapper**  
President

ken@1speedway.com  
Office: 818.362.5865  
Cell: 818.326.1286  
Fax: 818.362.5608  
13040 Bradley Avenue  
Sylmar, CA. 91342  
www.1speedway.com

MIKE QUIROGA  
President/CEO  
O: 818.780.8820  
F: 818.780.1713

16046 Blythe St.  
Van Nuys, CA 91406

**MIKE'S<sup>th</sup>**  
**ROOFING & BUILDING**

ANNIVERSARY 1972-2012

MIKE'S GOT YOU COVERED

www.mikesbuilding.com

# NEXT MEETING???

## Please keep checking out site for Updates

---

### CHAPTER 40 -- SAN FERNANDO VALLEY V-8'S CLUB

#### MONTHLY MEETING MINUTES FOR *Continued*

Information from the V-8 National Club: Membership drive: May 1 through Aug 1, there's a contest among regional chapters including ours, for new members sign-ups. Think about your circle of car friends, particularly younger people. When we're staged at car shows, it's a great opportunity to reach out to interested individuals and invite them to our meetings. Let's go get 'em! Info on Western National meet: For year 2021, the Western National Meet will be held at Lake Tahoe. Drive it! Saturday June 20 has been designated 'National Drive Your Early Ford V-8' Day.

**Christmas Party, 2020:** VP Jim Ellerbrock gave information about this years' Christmas Party. Because of a pricing increase of \$1500, )wow!(, Jim has been looking around for a new place for our next Christmas party. Woodland Country Club is one possibility. His goal is to hold the cost to the same as last years' Christmas party. Any ideas please call Jim.

**7:15 pm: Break called**

**7:35 pm: Meeting resumed**

#### **Report from Officers:**

**Secretary: Rex Jaramillo** -- all OK. Rex took the opportunity to introduce two additional guests, his friends Bill and Joan Dietrick. The Dietrick's are the proud owners of a beautiful '36 Ford 4-door convertible. This fine Ford has some great history, it's been in the family for many years. Coincidentally, Rex is presently working on the car, performing mechanical refurbishment and upgrades. Welcome to the Dietricks!

**Treasurer: Joan Sapper** gave the treasurers report. All OK.

**Tours: Ken Sapper** gave the Tours report. The Friday March 20 Tour was to be at the Strathern House. It's been canceled. President Ernie received a call from the Museum saying they're closing their doors for awhile because of the Coronavirus pandemic. So no Tour.

**Driveline Editor: Rob Glucksman** gave his report, all good. He asked us to provide him a short bio about our cars. He also encouraged us to check our Club's Website and the Club Facebook site. A big thanks to Scott Doudrick for his part in setting these up and maintaining them.

**Membership/Directory: Howard Brown** provided an update about the Club's membership database that he's been working on. It's updated and complete, includes email addresses. This is huge, better communication is always good. And Jerry Litner finished the cover for our Drive Lines magazine, will be out in a month or two. Thanks to both of you.

**Car of the Month: Vasken Hagopian**, 1934 Ford 2-door sedan. He bought it ten years ago, has done many upgrades, just finished installing power steering. More information about this car later in this Newsletter.

**Ladies Raffle: Handled by Bobbie Searl.** Beautiful flower arrangements were won by Joan Dietrick and Valerie Ellerbrock.

**Birthdays for March: Handled by Bobbie Searl.** Oh how we love our birthdays, many delighted individuals were mentioned.

**Name Badge Award: Handled by Karen Lehman**, won by Sandy 'Semi-custom' Norris.

**Program: Ralph Hubbard** was our speaker for the evening. Ralph is a Club member and an expert in old Ford pricing and valuation.

**Prize Raffle: Handled by Steve Lehman.** Many gifts were won by many happy people.

**50/50 Raffle: Handled by Ken Sapper**, won by Harry Baker.

**8:55 pm: Meeting adjourned**



# Program / Speaker

**Program: Ralph Hubbard** was our speaker for the evening. Ralph is a Club member and an expert in old Ford pricing and valuation. He's currently in the process of liquidating a collection of over 100 cars, with 50 remaining. This past year, he attended various car auctions including David Gooding, Russo Steele, and Barrett Jackson. His goal: Better understand the present-day old Ford car market. What Ralph discovered was that generally speaking, our old Fords are not selling for what they were in the recent past. Classic cars in general seem to be dropping in value. Some street rods seem to be holding their own. However, fiberglass-bodied versions have plummeted in price. Interestingly, reproduction steel-bodied cars have also dropped in value. One example: A '32 Ford with a steel Brookville body sold recently for \$33,000. Eight years ago (2012), a similar Brookville-bodied street rod sold for \$60,000. So what are some real-world examples of old Ford values? Using a slide presentation orchestrated by Scott Doudrick, Ralph scrolled through photos of numerous early Fords which were recently consigned to auction for sale. These included a variety of years, and ranged from amateur restorations to top-dollar builds. So here's an interesting overview of early Ford's Ralph shared with us: First up was a '32 Ford truck, equipped with a 'banger' 4-cylinder engine nicely hopped up, sold at auction for \$22K. Next was a '34 Ford Vicky, original and very nice, went for \$28.6K, cheap! Then there was a '34 Ford Phaeton, very nice, \$44K, very low. A '36 Ford, hopped up with a small block Chevy adapter-plated to the stock Ford running gear, sold for \$78K. A '36 Ford convertible (not a Phaeton) sold for \$27.5K, low, low! A '36 Ford 3 window coupe sold for \$78K, high! A '37 Ford truck, mildly souped up, went for \$33K, not a bad price. A '39 Ford with Chevy power and A/T yielded \$78.1K. A '40 Ford convertible, nicely modified, went for \$46K. A 1940 Merc convertible retro'd/created from a coupe sold for \$55K. A '41 Ford pickup, fair condition, velour interior and a crooked bed, a good 20/20 looker, fetched \$16.5K. A '46 truck, nicely finished in red, went for \$27.5K. In some opinions, front end not too attractive! A nice looking '47 Ford coupe with a '46 decklid and chrome trim around the back-quarter windows went for \$9.9K. A 1950 Ford convertible, a 99-point Dearborn car yielded \$38.5K. A 1950 Merc coupe, nice restoration but wrong upholstery, went for 29.8K. On the sale of street rods, Ralph observed that those displaying high quality seemed to be fetching high dollars. In summary, Ralph provided some very insightful, real-world pricing for us. Some of the \$ value information he shared might not have been what we were expecting. However, it's the reality in our day and age. So Ralph's parting advice is probably the best: 'Have fun restoring and driving them'. Thanks, Ralph great info and advice!

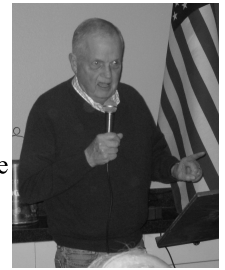

---

## CAR OF THE MONTH

**Pam Buck & Karen Lehman**, picked the car of the month. They chose Vasken Hagopian's 34 Ford Tudor

1934 FORD 2 DR SEDAN, PURCHASED IN 2012 IN LA CRECENTA CA. NO RUST.

IT CAME WITH A 283 MOTOR BOLTED TO THE ORIGINAL FORD TRANS AND REAR END, IT RUNS AT 265 DEGREES.

I HAVE INSTALLED FRONT DISC BRAKES, ELECTRIC HYDRAULIC MASTER CYLINDER, ELECTRIC POWER STEERING, NEW GAS TANK WITH VDO SENDER AND GAUGE TUCKED UNDER DASH. NEW UPHOLSTERY, WIRING, AND INSTRUMENTS. NEXT PROJECT IS MODERN SHOCKS TO SMOOTH THE RIDE.

ONE OF MY BEST FRIENDS DON ZABEL SAID "IF YOU GIVE ME THAT 283 MOTOR I WILL GIVE YOU A COMPLETE GOOD RUNNING FLAT HEAT" I ASKED DON WHAT

HE WAS GOING TO DO WITH THE MOTOR? HE SAID " I JUST LOVE CHEVY MOTORS". IT DID NOT HAPPEN. GOD BLESS YOU DON, WE ALL MISS YOU.

PEOPLE SAY HERE COMES BERNIE SANDERS IN A 34 FORD. AM I THAT UGLY?????? NO POLITICS.

THANK YOU FOR SELECTING MY 34 FORD FOR THE CAR OF THE MONTH.

Vasken Hagopian / futuretico@att.net



---

### Member Bio, Featuring

### Steve Boskovich

Growing up on a farm in Tulare, Ca. in 1953, I was introduced to driving trucks at an early age. At fourteen, my cousin taught me how to drive my Grandpa's 1929 2-ton Model A truck with 8 gears. I would help him out by driving around the farm and picking up alfalfa to feed the cows. He also had a 1940 Chevy pickup truck that I drove around in. I remember driving that to school while in the eighth grade!

In 1954 I moved to Chatsworth to live with my Dad and brother and although I was only 15, began driving his 1952 Ford pickup with an overhead 6 cylinder overhead engine. By 1955, when I began high school, I had purchased my first car...a 1951 Ford Club Coupe, black, with Fordomatic, a rarity, since only 4% of Fords had Fordomatic. I had saved my money from working to buy it. I drove it on my first day of high school to Canoga Park High. I remember parking across the street from school that first day and when I went out to my car after classes, two of my moon hub caps were missing! A common event in those days.

Well, the 1951 started to have issues, so I purchased my friend's 1947 blue Ford Coupe that was all hopped up. This is the car that I had when Sue and I met. I picked her up for many dates in that car until the transmission went out.

My next car was a beautiful 1950 Ford convertible, painted black with a white top. It had moon hub caps, was lowered and is the car shown in the picture below. This is in 1958 and Sue is wearing my Letterman jacket and I am wearing my FFA jacket. Fun times!

By 1959, I changed cars again and purchased a 1957 Ford Fairlane, a black hardtop. This lasted until we got married in 1961 when for some unknown reason, I purchased my one and only Chevy. I was a 1958 bronze Chevy Biscayne. I saw the error of my ways by 1963 and returned to Fords. Purchasing a 1963 Ford Fairlane.

The rest, they say, is history. Fords forever since then.



Boskovich Steve & Sue JAN . 58

# From The President

Hello Everyone,

We had a great turnout for our March meeting. We had a lot to talk about. Rob is hoping to get this out prior to our March tour to the Strathearn Museum. Besides the museum they have a nicely layed out site with other Simi Valley related historical buildings. I'm looking forward to it. It was sad to hear about the passing of one our former members and past President (1998) Dennis Keene. Hope to have some info regarding any services soon. For our April meeting, we'll have a couple out great tours/Car Shows to talk about. First we have the "The Poppy Run 2020" with the Corvair Club on April 5th . I spoke to Jack Pinard and they will meeting at the Trader Joes parking lot in Granada Hills 11114 Balboa Blvd at 8am(departing around 9am). I have done this tour a couple of times, once with my 48 Plymouth and the other with my 55 Dodge.

The second tour is the(Rails& Road Car show) at the Live Steamers Site next to Griffith Parks Travel Town on April 26th. Once again this is a great show which our club is invited to. Our own John Kemmerer is coordinating it on behave of our club. Hope to see a lot of you at these events. Once again, Jerry Littner has stepped up to offer his assistance showing a prelim of the 2020 Club Roster (Looks Great), also he is doing some research regarding some ideas for V8 Club merchandise, He may become our resurrected "Accessories Chairman"! If any of you have any ideas, feel free to investigate and let Jerry know what you have found out. I'm looking forward to seeing you all at these upcoming events and also at the April 7th Club meeting.

Prez Ernie

---

---

## FROM THE EDITORS DESK

16 Mar 20

**WELL, Short of an official declaration of "Marshal Law" from our Gov & Mayor, Ca. Is been somewhat Shut down, With that, So has Our upcoming Tours, &&& Next Meeting.....**

**That being said, Most of the newsletter was written prior to the shut down, So, some of the info / comments are outdated.**

**Please Check with one of the Board Members & our Online pages for follow up info**

---

---

### *CHAPTER 40 -- SAN FERNANDO VALLEY V-8'S CLUB*

#### MONTHLY MEETING MINUTES FOR

Tuesday March 3, 2020

**7:00 pm** Meeting called to order

President Ernie Baily launched the meeting, opened with Pledge of Allegiance. He then welcomed guests and announced a swell cupcake give-away.

Words from our President: Guests: Ernie welcomed our guest Chris Hayes, who has a '41 Ford 4-door sedan, a project in-progress. Welcome, Chris, hope to see you again.

Reagan Library Tour: This tour was a good time had by all who attended. Our Club teamed up with the Ventura Chapter for a fantastic time.

Other items of business: **Bio's wanted**: President Ernie would like a brief bio from each one of us. We've got some very interesting people amongst us, yeah you! It's a great opportunity for us to share about our background, our cars, and any other pertinent info that comes to mind.

**Club dues**: Payments for our local Club and National level Club are now due. See Howard Brown to pay up for our Club. To pay your National dues, you can go online to the Early Ford V-8 Club of America. In their website you can print an application and mail it or you can renew on-line using a credit card. Good stuff!  
2020 membership roster cover:

**Jerry Litner** is working on a new cover for our 2020 roster. Stay tuned for a work-of-art cover, Jerry's the best. Good news from the Baily Brothers: Ernie and Howard Brown teamed up and got Ernie's brother's '56 Studebaker Golden Hawk running and on the road for the first time in 35 years. That's good news, congrats, fellows!