

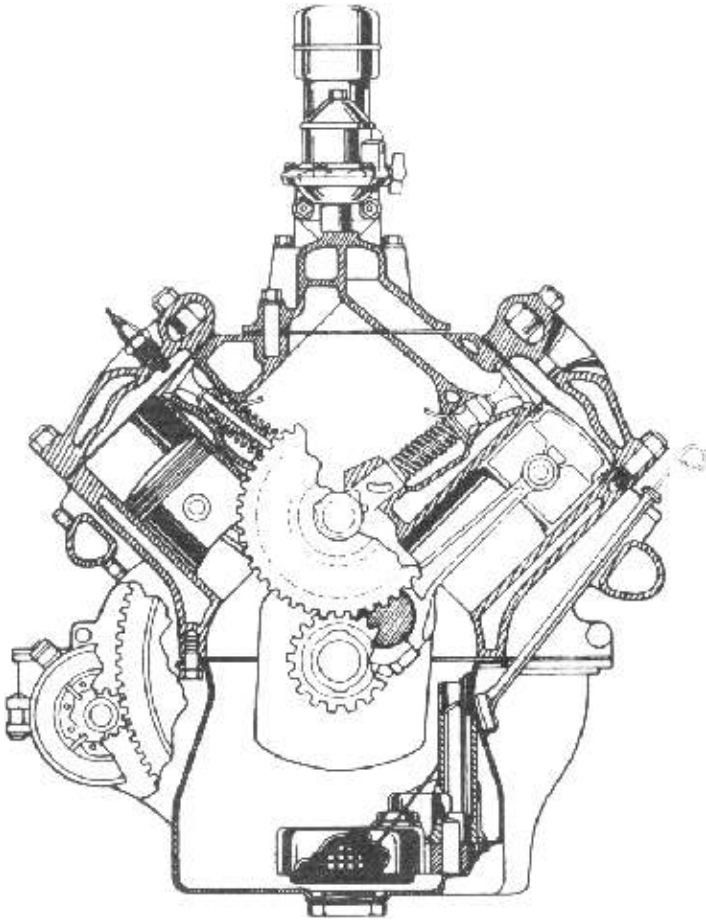

Drive Lines

Chapter #40
Our 47th Year
Visit Our Website
"valleyV8s.org"

June 2018



The Valley V8's
9700 Farralone, Chatsworth, Ca. 91311

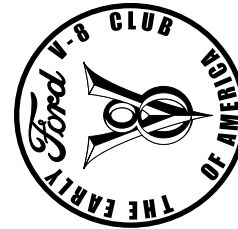

The Valley V8's

2018

President	Vaskin Hagopian	323-661-2044
Past Presidents	Don Durkee	
	Stan Miller	818-360-4812
Vice President	Steve Lehman	818-885-6938
Secretary	Rex Jaramillo	213-706-3854
Treasurer	Joan Sapper	818-249-5686
Tours	Kenney Sapper	818-249-5686
	RichCarter	708-567-2393
Programs	Larry Caplan	818-363-2849
	Joe DiFatta	818-700-1939
Membership	Harry Baker	818-632-9017
	Joan Sapper	818-249-5686
Drive Lines	Robert Glucksman	818-618-1395
	Jim Kelley	310-795-0704
Prize Raffle	Steve Boskovich	818-341-6876
50/50	Ken Sapper	818-380-5686
Ladies / Birthdays / Sunshine	Bobby Searl	818-353-6767
Name Badge	Karen Lehman	818-885-6938
Car of the Month	Jerry Jensen	805-491-3355
Web Master	Scott Dudrick	818-687-9836
Tech. Advisor	John Wolf	818-789-6201

Meeting: 1st Tuesday of the Month, 7:00p
No host Dinner, Starting at 6:00p
Rosie's BBQ & Grill, 8930 Corbin Ave.
Northridge, Ca. 91324

Visit our Web Site: valleyv8s.org

Drive Lines is Published by
The San Fernando V8's Regional Group 40
of the Early Ford V8 Club of America
9700 Farralone, Chatsworth, Ca. 91311

The Valley V8's

Past Presidents

Jim Rowe	1971
Doug Peterson	1972
Don Durkee	1973-1974
Ed Warnock	1975
John Busk	1976
Chip Werstein	1977
Stan Misraje	1978
Bill Culp	1979
Al Spencer	1980
Larry Caplan	1981
Bob Rose	1982
Don Durkee	1983
Paul Kirk	1984
Kent Lowry	1985
Dave Sanborn	1986
John Kemmerer	1987
Dudley Ochsner	1988
Jerry Jensen	1989-1990
Joe DiFatta	1991
Chuck Shubb	1992-1993
George Richards	1994
Jerry Littner	1995
Dick Smith	1996
Chuck Mair	1997
Dennie Keene	1998
Rose Golt	1999
Don Stout	2000
Steve Boskovich	2001-2002
Joe DiFatta	2003
Wendi Potter	2004
Ken Sapper	2005-2006
Stever Batesole	2007
Harry Baker	2008-2009
Dave Bergman	2010
Randy Watson	2011-2012
Steve Boskovich	2013-2014
Stan Miller	2015
Don Durkee	2015
Vasken Hagopian	2016-2018

"Your Ad Here"
For only \$5.00 a month,
YOU

can have your
business card ad
right here

For more details,
Please call or Email Rob at
818-882-2002, / madmodelr@aol.com
Please put "Drivelines" in the subject
Please make all payments to
"Valley V8 Club"



Hello Fellow Members...
We would like to know more about
You, Your Car...

So, What I would like from our
members is a picture of you with your
car, with a small story. (1 Paragraph)
That way, We get to learn more about
our members, & we can put a face to
a name & car

Please make all submissions to ether
"Drivelines" at madmodelr@aol.com, or
"Drivelines" 9700 Farralone Ave.
Chatsworth, Ca. 91311

Thank You
Rob Glucksman, DL Editor



R.H.FACTOR GRAPHICS
Computer Graphics
Desktop Publishing



Robert Glucksman
Chatsworth, Ca. 91311
Office: 818-882-2002
Cell: 818-618-1395
madmodelr@aol.com

For all your Pre-Press needs

"We Fix 'Em"

THE RADIATOR WORKS

Auto Cooling System Services

(818) 701-0504
(818) 701-0536

18255 1/2 Parthenia St.
Northridge, CA 91325



ARBONNE
INDEPENDENT
CONSULTANT

Steven Lehman
Arbonne Independent Consultant
Consultant
23592171

Reset, Restore, Rebalance
Discover Ultimate Health,
C 818.517.1268

ArbonneForever@yahoo.com
www.stevenlehman.arbonne.com

**SPEEDWAY
ENGINEERING**



Ken Sapper
President
ken@1speedway.com
Office: 818.362.5865
Cell: 818.326.1286
Fax: 818.362.5608
13040 Bradley Avenue
Sylmar, CA. 91342
www.1speedway.com

Program: Peterson Automotive Museum: It's a survivor!

Mr. Steve Young was our speaker for the evening. Steve is an attorney, and has been on the Peterson Automotive Museum board of directors for 14 years. The Museum has been through some tumultuous times, and Steve shared with us some interesting insiders information. **Beginnings:** The building was originally built in the early 60's to house a department store which sold high-end Japanese products. It even had a coy pond on the top floor. However there wasn't much of a market for these goods at this time, so eventually the building became an Ohrbach's Department store. Then Orbach's went out of business, which left the building vacant for six years. **The Museum early years:** In 1994, Robert Petersen, owner of Peterson Publications (Hot Rod Magazine, etc.) selected the building to be used for an automotive museum. It was launched initially with funding from private donations combined with local bond measure funding. Over time, the donations slowed, and eventually the bond was retired with a check for \$25 million from Margie Peterson, Robert Peterson's wife. So the funding to keep the museum open was provided mainly by the Peterson's. Robert wrote the checks for maintenance, upkeep, and so forth. **Troubles and the fix:** In 2007, Robert Peterson died before his estate planning was completed. When he died, his donations stopped. A year later, in 2008, the Recession hit, throwing the museum into even deeper financial trouble. The outlook was bleak. About this time, Steve Young (our speaker) stepped in. Now Steve's a car guy, and he had a passion to ensure that Peterson Museum survived. So he agreed to step up and become Chairman of the Board for the Museum. Because of Steve's commitment, Margie Peterson entrusted \$150 million toward the Museum. So for five years afterward, Steve Young served as captain of the survival ship, guiding the museum through some very troubled financial waters. The Museum's survival was due in great part to Margie Peterson's financial backing and Steve's leadership, and he did it for no pay! This guy's amazing. The Peterson Automotive Museum today: The museum presently has over 100 vehicles for public display in its 25 galleries. The remaining part of the collection is kept separate in the basement level of the building. The ground floor focuses on automotive artistry, showcasing an assemblage of high-end exotic automobiles. The second floor focuses on industrial engineering, also the design and performance aspects of the automobile. Special displays on this floor include purpose-built race cars, motorcycles, hot rods and customs. The third floor recounts the history of the automobile with an emphasis on the car culture in .

So who is this guy Steve Young? Well for starters, he's an amazing attorney, as chronicled in the above account of helping save the Museum. And he loves cars. His first high-school car was a '50 Plymouth 4-door, in which he installed a 318 V-8, what a sleeper! Next car was a '56 Chevy with a 265 V-8 that he bought from a high-school teacher. Also during his high school years, he restored two Model A Fords. Over the years many other cars followed, a '65 Pontiac GTO, a '55 Chevy A-gasser, a few vintage early 60's Corvettes, a Roger Penske car, a 427 Cobra SC, and other cars too numerous to mention. Steve presently owns a 55 Chevy Bel Air, very quick, runs a 383 stroker mill. Also in his possession are two '32 Ford roadsters, a '33 Ford 3-window coupe, and a '34 Ford 5-window. We're telling you, he's a car guy through-and-through! Thanks Steve for an excellent presentation, and thanks for all you did to help save the Museum!



Car of the Month: Ernie Bailey is quite the car guy, has had a string of old V-8 Fords. He's also been a member of our Early V-8 Club for over 40 years! And he's got this beautiful black 1955 Dodge Custom Royal Lancer hardtop that's oh so swell, you've all seen it before. Dodge, you say? Yep, there were no old Ford's present at our Club meeting. So by default, the Car of the Month honors went to Ernie and his Dodge. Ernie's first car was a '55 Dodge just like it, and he bought this one almost 30 years ago as a tribute to his first one. It still has the original Dodge Red Ram, 270 cu. in. hemi. It's been rebuilt, bored 30-over, and equipped with a mild Isky cam. It still has the factory small-based four-barrel carburetor. Over the years, he's had the Dodge painted, did research on the interior patterns, and had it reupholstered. He also put in a new wiring loom, rebuilt the transmission, the rear end, the rear suspension, and installed a lowering kit, a very subtle drop, though! In all, this early Mopar is a nice package well done. Congratulations, Ernie, nice car!



*And now for some
"Pressing" News*

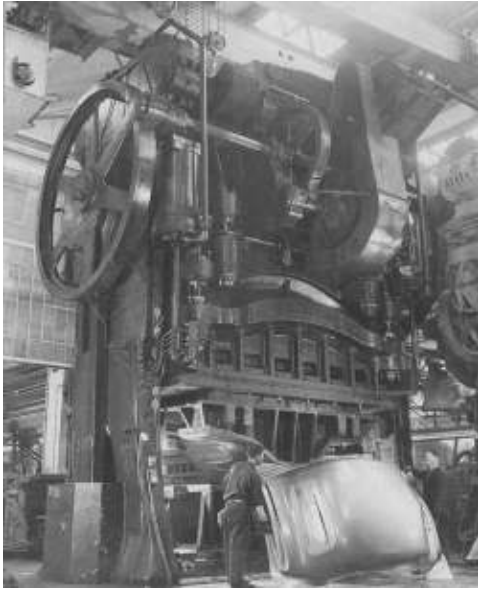

Drive Your Car!:
Steve Boskovich reminded us that
Phil Hall, National President of
The Early Ford V-8 Club of America,
declared June as
'drive your old Ford'
(or 'other old car') month.



June 5th Meeting
Our speaker will be Silvia Duncan & Sharon Kopito
Who will be giving a demonstration on C.P.R.
Bring a Guest, See you on the 5th

NEW MEMBERS

*The May 1st meeting has brought our family 3, yes 3 New
Members*

Walter Hanna, He is the proud owner of a 1947 Ford
Fordor Sedan

And then we have

Oliver Calibet & Sandrine Cutright, They are the
proud owners of a 1953 Ford Sunliner

Welcome to the Club



UPCOMING SHOWS

June 2: LAPD Car Show @ Warner
Center

June 3: All GM Car Show @
Warner Center

June 3: Pomona Swap Meet

June 10: Long Beach High Perf.
Swap Meet.

July 1: Montrose Car Show
(in Memory of Don Zabel)@
2200 Honolulu Ave

July 21: Cruise Night @ Glendale on
Brand Blvd

July 22: Wounded Warrior Car Show

Chapter 40 -- San Fernando Valley V-8's Club

Monthly Meeting Minutes for Tuesday May 1, 2018

7:00 pm: Meeting called to order

President Vasken Hagopian welcomed the group to the Meeting, then led us in the Pledge of Allegiance.

Guest Introductions: Walter Hanna, Oliver Calibet and Sandrine Cutright were our new guests. They also became new members tonight! Welcome aboard, Walter, Oliver and Sandrine.

Opening comments by our President: 1) Memorial Day Beginnings: Vasken gave a background of Memorial Day. It has its roots in the Civil War Days when Americans gathered in late spring to honor the fallen. At that time it was known as 'Decoration Day'. In 1971 it became a federal holiday. 2) Coffee & Kix: It was a great Coffee & Kix put on by Don Stout. There were lines of cars going around the block in all directions, good job, Don, thanks for opening up your place for us and other car nuts! 3) Club name badges: keep wearing 'em! For this meeting, Karen Lehman only collected 25 cents from one person, good work, members, keep wearing them! And let Karen know if you don't have a badge. 4) June meeting: Will feature CPR training, good info for all of us. 5) Next meeting: Tuesday June 5 is our next meeting. 6) Drive your V-8!: Saturday June 16 is still designated 'Drive your V-8 day'. Vasken encouraged us to drive our old cars to the June 5 Club meeting.

Other comments: Drive Your Car!: Steve Boskovich reminded us that Phil Hall, National President of The Early Ford V-8 Club of America, declared June as 'drive your old "Ford" (or 'other old car') month.

Reports from Officers:

Secretary – Rex Jaramillo: Everything OK.

Treasurer -- Joan Sapper: Everything OK. Joan gave a Club financial report.

Drive Lines Editor – Robert Glucksman: Mentioned that we have two business cards in Driveline. He encouraged us to give him pics, information, etc. about our cars to be included in Drivelines Newsletters.

Tours – Ken Sapper: Swell Cruise! Ken is still working on the California Oil Museum visit. It would be a nice cruise up to Santa Paula, afterwards we'd gather at a local restaurant for lunch. At this time it's likely going to be a weekday tour, probably a Friday. NASCAR News: Talladega this past weekend (End of April): 6 out of 7 top winners were Fords.

More Car Events: Vasken reported on a few more Car Activities. May 4-5: Edelbrock Car Show. May 12: Paso Robles Wings & Warbirds. May 13: Long Beach High Performance Swap Meet. June 2: LAPD Car Show. June 3: All GM Car Show. June 3: Pomona Swap Meet. June 10: Long Beach High Perf. Swap Meet.

Membership/Directory – Vasken will follow up on dues paid, etc.

7:30 pm: Break called **7:50 pm: Meeting resumed**

(Monthly Meeting Minutes Continued)

Car of the Month: Ernie Bailey is quite the car guy, has had a string of old V-8 Fords. He's also been a member of our Early V-8 Club for over 40 years! And he's got this beautiful black 1955 Dodge Custom Royal Lancer hardtop. Congratulations, Ernie, nice car!

Ladies raffle: Handled by Bobbie Searl. Nice plant arrangements were won by Judy Shubb, and by one of our new members Sandrine Cutright.

Mother's Day: The ladies present at the Meeting were honored with roses prepared by Evelyn Hagopian. Thank you Evelyn, great work!

Birthdays for May: Bobbie Searl recognized the following ecstatic individuals: May 1 – Leslie Nuccitelli May 2 – Patty Schneider May 3 – Bobbie Searl May 9 – Jean Knapp May 13 – Brandon Jacobson May 15 – John Fredricks May 17 – Rich Carter May 19 -- Sue Boskovich and Paul Kirk May 27 – Helen Baker and Diane Baily May 28 – Zita Goeschl May 31 -- Judy Shubb.

Gerard Buck announced the upcoming Marina Del Rey Yacht Club Car Show activity: July 29, 2018.

Name Badge: Handled by Karen Lehman, won by a prosperous Pam Buck.

50/50 Drawing: Handled by Ken Sapper, won by a pleased Phil Goeschl.

Program: Peterson Automotive Museum: It's a survivor!

Mr. Steve Young was our speaker for the evening. Steve is an attorney, and has been on the Peterson Automotive Museum board of directors for 14 years.

Raffle: Handled by Steve Boskovich. Many winners took home some nice prizes. Thanks, Steve for handling the Raffle, welcome back!

Vasken: Announced next Club meeting date, June 5.

8:35 pm: Meeting adjourned.

Minutes submitted by Rex Jaramillo



FROM THE PRESIDENT.

HAPPY FATHERS DAY, HAPPY FLAG DAY, AND SUMMER BEGINS ON THE 21ST.

We had another full house of members, but no classic cars, due to rain.

Our guest speaker was Mr. Steve Young (not the 49ers qtr. back). He gave us the insides of the Peterson Museum.

By being the president for Peterson, he informed us very well, how Peterson started from the corner where Ohrback Dept. Store was.

Mr. young has a collection of beautiful classic cars, he could have gone another 3 hours talking about his classic cars.

I remember in the early 60's when I was going to Hollywood High School, I dated these two Italian sisters (one at a time). They worked for Peterson publishing.

They were my class mates, and both retired about 4-5 years ago from Peterson. Yes we are still in contact, we talk about the good old days, the kids and grand kids.

June is the month to drive your classic Ford to the meeting, this is a national event. Imagine all the beautiful classic Fords across the United States.

Fathers Day: Why is it on Mothers Day you see all the advertisements for diamonds, shoes, clothing, flowers, etc. but on Fathers Day, Home Depot, tools, work boots, screw drivers, etc. Women cry for equality, what about us men?

Looking forward for our guest speaker/demonstrator, nurse for our C.P.R. class. no live person to demonstrate on, only a Mannequin, (no mouth to mouth).

Evelyn and I are going to Cancun for our anniversary, birthday, etc. This is our fourth trip to Mexico. We will be visiting the Mayan Temples, ruins, old sites.

Let us not forget the Cantinas, do you remember the song by Pat Boon, Speedy Gonzales?

Please bring a friend to our meeting, let us increase our membership, new ideas.

Happy Fathers Day.

Vasken Hagopian

