



Drive Lines

Chapter #40

June 22

Our 51st Year

Visit Our Website

"ValleyV8s.org"

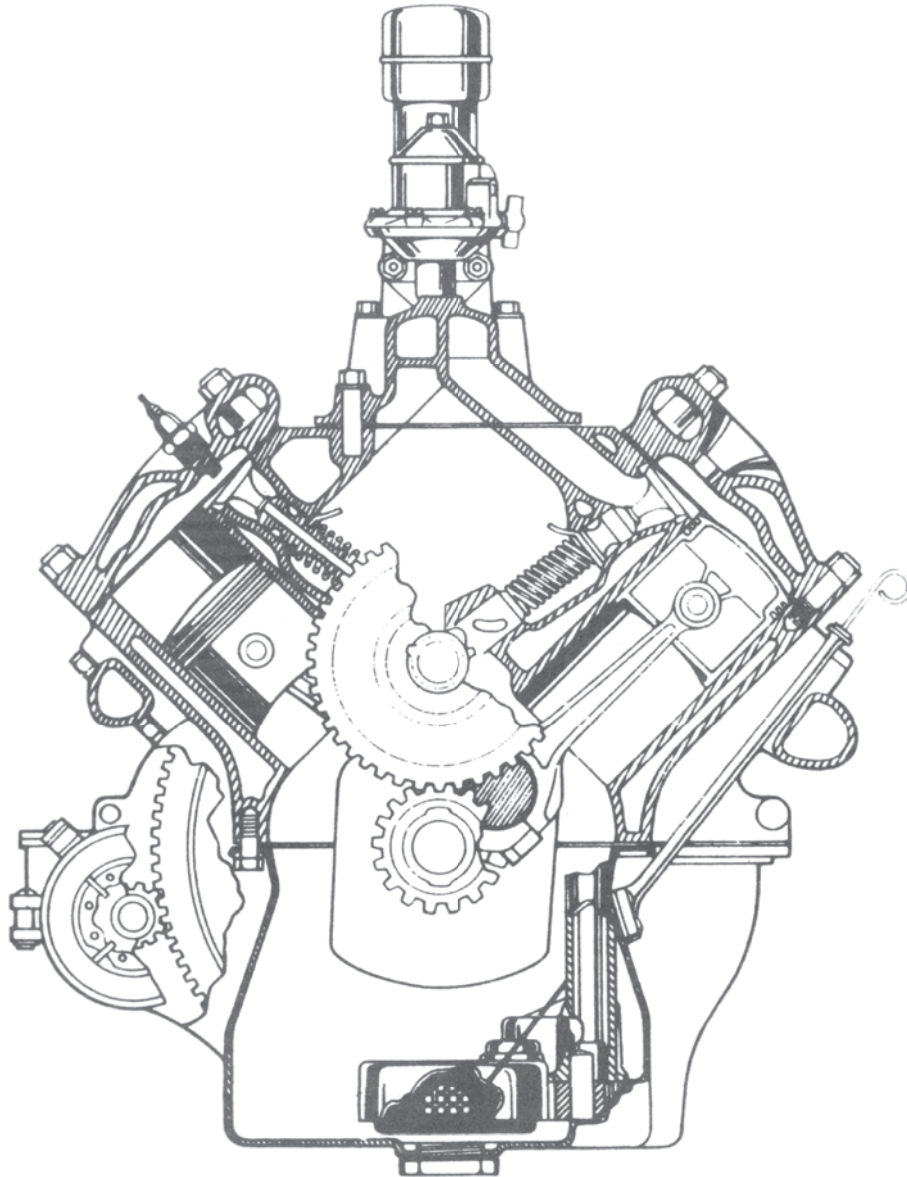

The Valley V8's
9700 Farralone, Chatsworth, Ca. 91311

The Valley V's

2022

President	Ernie Baily	805-433-5540
Past Presidents	Vaskin Hagopian	323-661-2044
Vice President	Jim Ellerbrock	818-437-0412
Secretary	Rex Jaramillo	213-706-3854
Treasurer	Joan Sapper	818-326-9685
Tours	Ernie Baily	805-433-5540
Programs	Larry Caplan	818-363-2849
	Joe DiFatta	818-700-1939
Membership	Howard Brown	818-606-0267
	Joan Sapper	818-326-9685
Drive Lines	Robert Glucksman	818-618-1395
Prize Raffle	Steve Lehman	818-885-6938
50/50	Ken Sapper	818-326-1286
Ladies / Birthdays / Sunshine	Bobby Searl	818-353-6767
Name Badge	Karen Lehman	818-885-6938
Car of the Month	Jim Ellerbrock	818-437-0412
Web Master	Scott Dudrick	818-687-9836

Meeting: 1st Tuesday of the Month, 6:00p

Visit our Web Site: [valley V8s.org](http://valleyV8s.org)

Facebook: **Valley V8s**

(<https://www.facebook.com/groups/579123315803014>)

Drive Lines is Published by

The San Fernando V8's Regional Group 40

of the Early Ford V8 Club of America

9700 Farralone, Chatsworth, Ca. 91311

**For more photos of Club Events,
Please check out Web & Facebook sites**

**Looks like we have a new
"HOME" at Mimi's Cafe**

Past Presidents

Jim Rowe	1971
Doug Peterson	1972
Don Durkee	1973-1974
Ed Warnock	1975
John Busk	1976
Chip Werstein	1977
Stan Misraje	1978
Bill Culp	1979
Al Spencer	1980
Larry Caplan	1981
Bob Rose	1982
Don Durkee	1983
Paul Kirk	1984
Kent Lowry	1985
Dave Sanborn	1986
John Kemmerer	1987
Dudley Ochsner	1988
Jerry Jensen	1989-1990
Joe DiFatta	1991
Chuck Shubb	1992-1993
George Richards	1994
Jerry Littner	1995
Dick Smith	1996
Chuck Mair	1997
Dennis Keene	1998
Rose Golt	1999
Don Stout	2000
Steve Boskovich	2001-2002
Joe DiFatta	2003
Wendi Potter	2004
Ken Sapper	2005-2006
Steven Batesole	2007
Harry Baker	2008-2009
Dave Bergman	2010
Randy Watson	2011-2012
Steve Boskovich	2013-2014
Stan Miller	2015
Don Durkee	2015
Vasken Hagopian	2016-2018
Ernie Baily	2019-????

Mimi's Cafe
19710 Nordoff Pl.
Chatsworth, Ca. 91311

Our Next Meeting
7 JUNE 22

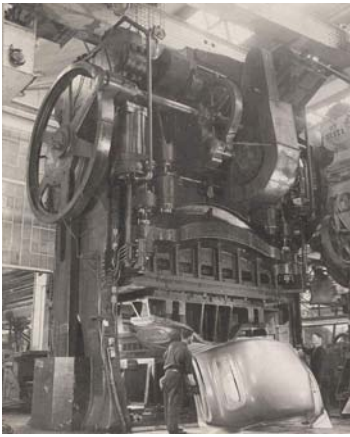

And now for some
"Pressing" News

What are you doing to stay Sane
Write Me something

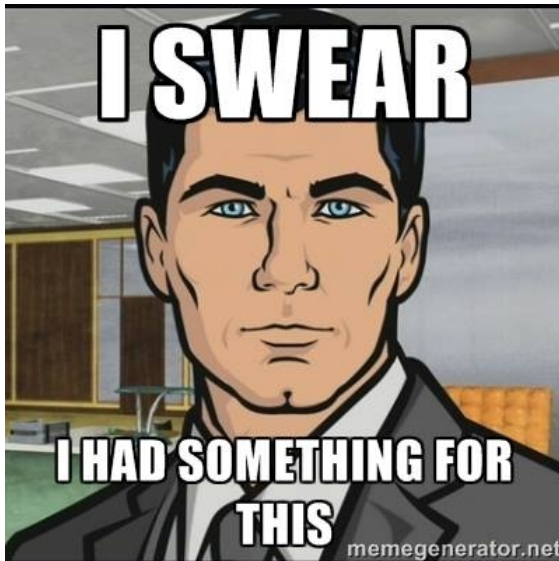

"Your Ad Here"
For only \$5.00 a month,
YOU
can have your
business card ad
right here

For more details,
Please call or Email Rob at
818-882-2002, / madmodelr@aol.com
Please put "Drivelines" in the subject
Please make all payments to
"Valley V8 Club"

HELLO FELLOW MEMBERS

We would like to know more about You, Your Car...
So, What I would like from our members is a picture of you
with your car, with a small story. (1 Paragraph)
That way, We get to learn more about our members, & we
can put a face to a name & car

Please make all submissions to ether
"Drivelines" at madmodelr@aol.com, or
"Drivelines" 9700 Farralone Ave. Chatsworth, Ca. 91311

Thank You

Rob Glucksman, DL Editor



SOLUTIONS IN PACKAGING AND GRAPHIC DESIGN

Steve Boskovich

Office (818) 341-2291
Cell (818) 903-6620
Fax (818) 341-1050

P.O. Box 4074
Chatsworth CA 91313



8744 REMMET AVE.
CANOGA PARK, CA 91304
(818) 998-0199
FAX (818) 341-2073

AL MOONEY
C.F.O.

al@mooneyindustries.com

**SPEEDWAY
ENGINEERING**



Ken Sapper
President

ken@1speedway.com
Office: 818.362.5865
Cell: 818.326.1286
Fax: 818.362.5608
13040 Bradley Avenue
Sylmar, CA. 91342
www.1speedway.com

MIKE QUIROGA
President/CEO
O: 818.780.8820
F: 818.780.1713

16046 Blythe St.
Van Nuys, CA 91406



ANNIVERSARY 1972-2012

MIKE'S GOT YOU COVERED

www.mikesbuilding.com

From The ~~President~~ Editor

So, My Friends, We are going into June, (WOW, Time moves too fast), & we are looking at our 3rd meeting at Mimi's & it looks like we are here to stay, so long Rosie's We had 33 members, & 9 Fords. Parking, Not a Problem

I'm taking this spot, since Prez Ernie is on holiday, & VP had nothing to write, not that I have so much to say. I've been somewhat land locked being swamped with work. That means I also havent had much time to drive



Chapter 40 -- San Fernando Valley V-8's Club Monthly Meeting Minutes for Tuesday May 3, 2022

7:00 pm Meeting called to order

President Ernie Baily was away, so Vice President Jim Ellerbrock launched the meeting, opened with Pledge of Allegiance.

Jim Ellerbrock: 1) Announced that Jerry Littner would be handing out the new Club rosters this evening. As always, Jerry did an amazing job, well done, Jerry, thanks for all the work. 2). Jim announced date for our club's most excellent Christmas party: That be Sunday December 11 at the Woodland Hills Country Club.

Officer's Reports: All OK

Joan Sapper: Gave treasurer's report, all good.

Steve Boskovich: Announced that there would be a summer barbecue in August at his home. Now that's some good news, we've had some swell times there, thanks, Steve and Sue!

Stan Miller: Shared information about a car collection owned by a friend of his who passed away. Extensive collection of at least 12 cars including a '32 Ford 4-door, many Ford Fairlanes, Thunderbirds, etc. Steve Bosovich bought his '57 Fairlane from the same collection. Contact Stan if interested.

7:25 pm: Break called

7:35 pm: Meeting resumed

Speaker for the Evening: Larry Caplan introduced our guest speaker for the evening: Our very own Ralph Hubbard. Ralph has extensive leadership involvement at the Early Ford V8 Club of America National level, including the office of President. So he is very qualified on all things early V-8 Ford.

Well done, Ralph, thank you for this 2nd series, and sharing this valuable information with us.

Car of the month: The Award for the month of May was handled by Rob Glucksman and went to Dick Colarossi and his yellow '32 Ford roadster with multiple carbs and a supercharger. Man, did you see it, the car was a beast! Thanks Dick for bringing it.

Ladies raffle: Handled by Bobby 'till those crops' Searl. Beautiful plants were won by Reen Jaramillo and Joan Sapper.

Name badge: Handled by Steve Lehman, won by Bill Greene.

50/50 Raffle: Handled by Ken Sapper, plush pot was won by Chris 'well-heeled' Haynes.

8:35pm: Meeting adjourned.

The Next Speaker

Our speaker for the June 7th program will be Al Mooney.... He will discuss how he got into collecting older Fords AND how is into singing!!!! Bring a friend and remember we are now at Mimi's !!!

SPEAKER

Speaker for the Evening: Larry Caplan introduced our guest speaker for the evening: Our very own Ralph Hubbard. Ralph has extensive leadership involvement at the Early Ford V8 Club of America National level, including the office of President. So he is very qualified on all things early V-8 Ford.

Ralph's talk was a continuation of his presentation a few months' prior about hammer prices for early V-8's sold at an auction in Scottsdale, AZ. This auction Ralph attended was hosted by Worldwide Auctioneers, yep, no typo, 'Auctioneers' vs. 'Auctions'.

Quick background Kruse International, then Worldwide Auctioneers: The well-known 'Kruse International' was founded in 1952 by Russell Kruse as a property auction company. They were based in Auburn, Indiana, and eventually they 'branched out': In 1971 on Labor Day, they held their first auction for collectible cars. Over time they became the largest auto auction company in the world. They were noted for conducting the William Harrah's 1,000 car collection sale, also the first to sell a car for \$1 million, a 1934 Duesenberg. They were even asked by Tom Barrett to conduct an auction in Scottsdale, Arizona, ring a bell? Regrettably, over time, they started losing money, stopped paying their customers, and eventually lost their auction license. As a result, Worldwide Auctioneers stepped in to fill the gap.

For the second part of his presentation, Ralph shared the 'hammer' price for numerous Ford's and Mercury's, some nice, some so-so, but all yielding some good pricing, all things considered.

Well done, Ralph, thank you for this 2nd series, and sharing this valuable information with us.



Car of the Month

Car of the month: The Award for the month of May was handled by Rob Glucksman and went to Dick Colarossi and his yellow '32 Ford roadster with multiple carbs and a supercharger. Man, did you see it, the car was a beast! Thanks Dick for bringing it.



There are some numbers from Ron Hubbard

Vehicle	Condition	Sold
1936 Ford Three-Window Coupe	Nice #2 condition.	\$45,000
1940 Ford Deluxe Convertible	Nice #2 condition, excellent fit and finish.	\$43,000
1940 Mercury Club Convertible	#3 condition, mismatch painted dash vs. tan interior.	\$37,500
1951 Mercury Monterey Coupe	Very nice #1 condition.	\$42,500
1948 Mercury Club Convertible	Excellent #1 condition (NOTE: Ralph knew of this car from 1966.	\$45,000
1932 Ford V-8 Five-Window Coupe	Nice #2 condition, older paint & interior.	\$45,000
1937 Ford Club Cabriolet	Nice #2 condition, 40-year old restortation. Prior Dearborn winner.	\$37,000
1937 Ford Cabriolet	Nice #2 condition.	\$57,500
1939 Mercury Sport Convertible	#2 condition. 20-year old restoration.	\$35,000
1940 Ford Deluxe Coupe	Excellent #1 condition. Well equipped: Radio, bumper guards, etc.	\$45,000
1938 Ford Deluxe Convertible Coupe	Nice #2 condition: Upgraded to hydraulic brakes.	\$41,000

1950 Mercury Convertible	Nice 2+ condition. Standard power windows, dual pipes, overdrive.	\$50,000
1939 Ford Deluxe Convertible Coupe	Older restoration, nicely equipped: Radio, fog lights, chrome spyder wheels.	\$45,000
1941 Ford Super Deluxe Convertible	Best buy of all: Owned by a series of renowned collectors.	\$25,000
1950 Mercury Club Coupe	#3+ condition. Stock 255 cu. In. engine with overdrive.	\$27,500
1953 Ford Crestline Victoria Hardtop	Nice #1 condition. Venerable 110 hp 239 cu. in. mill. Numerous options and accessories including overdrive, wire wheels and deluxe steering wheels.	\$30,000
1937 Ford Coupe	Carefully preserved original, including paint.	\$21,000

Our New "Home"

MIMI'S CAFE
19710 Nordhoff Pl.
Chatsworth, Ca. 91311

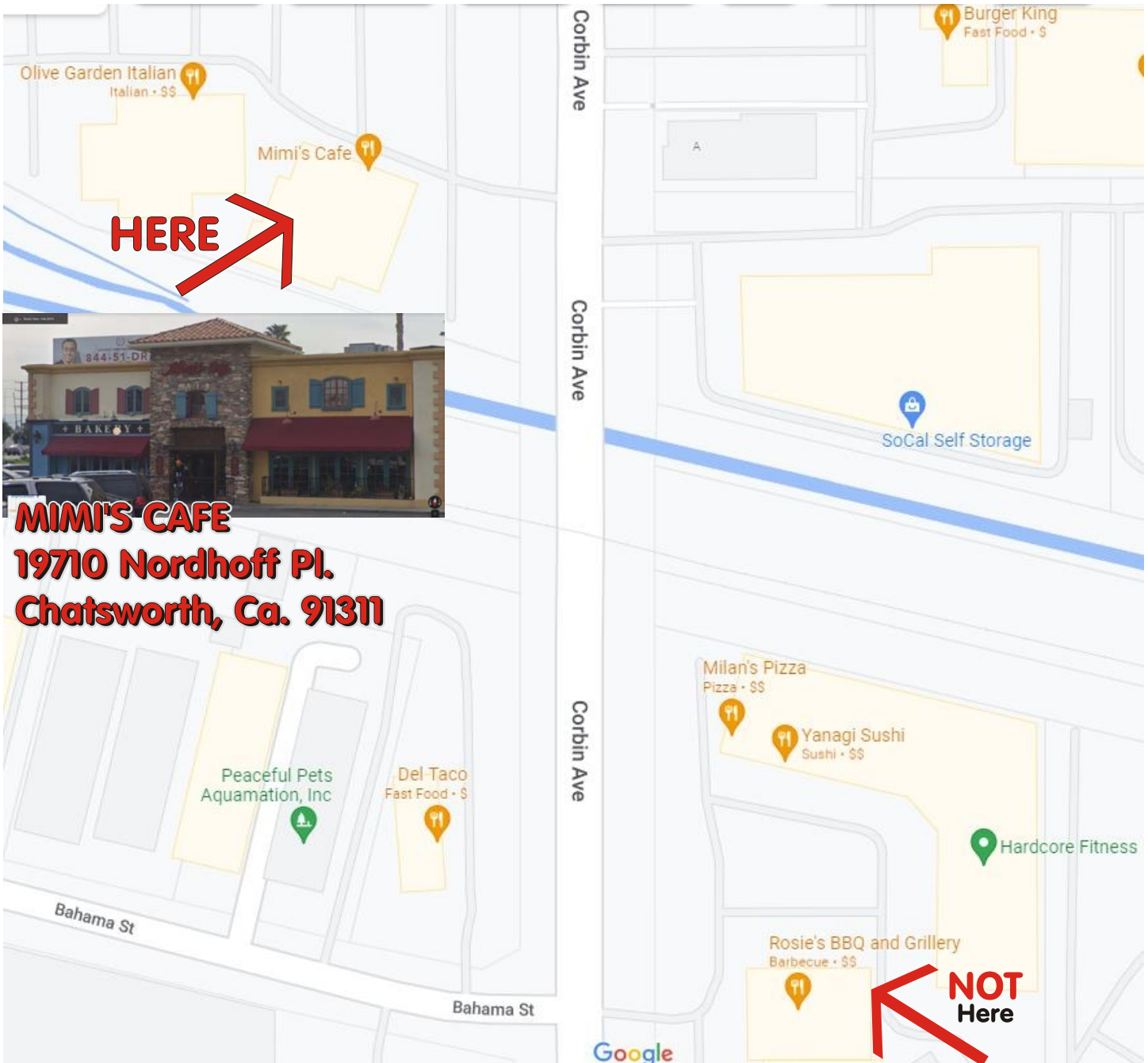

MIMI'S CAFE
19710 Nordhoff Pl.
Chatsworth, Ca. 91311

**NOT
Here**

LATE Breaking Prez Notes

Well Hello everyone,

I heard the May meeting went pretty well in the new area at Mimis. So I'll get to see it in person for the June meeting. I had a nice vacation/visit at my Sons home in Citrus Heights Ca just slightly north of Sacramento. I found a nice 1/43 scale 1932 Model B sedan car for my Xmas train layout(I like to add something to the Xmas layout every year.(my Xmas play time). When I got back I had to select the proper Red color for the 1933 Wards Hawthorne bicycle I 'm slowly restoring. This bike was handed down through my moms family which was my Moms oldest brothers bike bought new in 1933. After my uncle rode it a number of years it was handed over to my Mom who rode it thru her school years then handed off to my Moms younger brother, He rode it a number of years then it got put up in the barn. After number of years my uncle brought in down and restored it for me. He shipped it out from Cedar Rapids, Iowa to me and I rode thru elementary school and Jr High School. I stopped riding it just before getting my first car(my first 55 Dodge), Well the bike sat behind my Moms house for many years and then one day while at Moms house I went around back of the house and there it was. I realized the history of the bike and took it home and tore it down. It sat for another 10+ years in a box in my garage until about a year before I retired. I have been slowly redoing all the parts and the last thing to do was to get the frame repainted. Well, I took it to the shop to get the repaint before my vacation. I plan to pick it up in a week or so. Then all I have to do is to reassemble and go riding(before I forget how). I plan to make a vintage style bike rack for my 48 Plymouth and take with me to Car Shows. It should be Fun!

As far as my old car projects go, Rob is helping me with the repaint and Lettering of the Packard valve covers, He showed me the covers prior to the final clear coat and WOW! They look Great!. Rob is very detailed orientated and they look too good to put on the car. The other thing, I went with My brother to pick up the 56 Golden Hawk from trans shop after a complete rebuild of the transmission(What a differance!) I'm starting the tear down of my Plymouth, pulling the head to find out if it has a blown head gasket and/or valves problem. My Dodge is running fine but it lost all the Freon just a month after the warranty ran out. It never ends!

As far as tours go, Jim is close to getting a date for our Valley Relics Museum tour, Scott was looking into a Lunch/Brunch tour to Paradise Cove tour as well! also hope to have a board meeting to set up other future events too!

Well with all that being said I'll see you at the meeting!

Prez Ernie

