

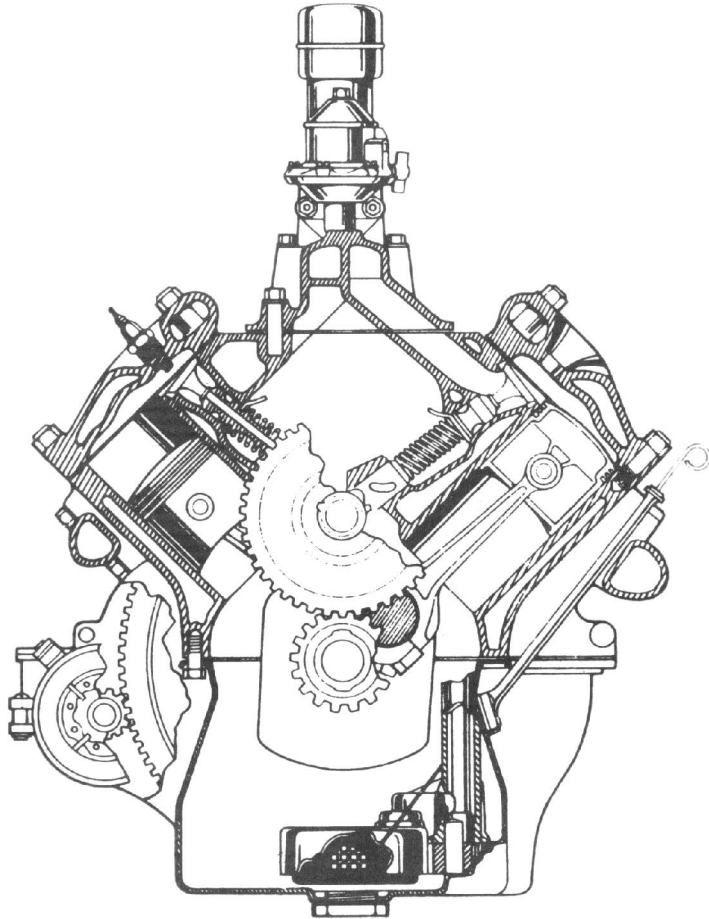

Drive Lines

Chapter #40
Our 47th Year
Visit Our Website
"valleyV8s.org"

February 2018



The Valley V8's
9700 Farralone, Chatsworth, Ca. 91311



The Valley V's

2018

President	Vaskin Hagopian	323-661-2044
Past Presidents	Don Durkee	
	Stan Miller	818-360-4812
Vice President	Steve Lehman	818-885-6938
Secretary	Rex Jaramillo	818-254-8452
Treasurer	Joan Sapper	818-249-5686
Tours	Kenney Sapper	818-249-5686
	RichCarter	708-567-2393
Programs	Larry Caplan	818-363-2849
	Joe DiFatta	818-700-1939
Membership	Jerry Littner	818-632-9017
	Joan Sapper	818-249-5686
Drive Lines	Robert Glucksman	818-618-1395
	Jim Kelley	310-795-0704
Prize Raffle	Steve Boskovich	818-341-6876
50/50	Ken Sapper	818-380-5686
Ladies / Birthdays / Sunshine	Bobby Searl	818-353-6767
Name Badge	Karen Lehman	818-885-6938
Car of the Month	Jerry Jensen	805-491-3355
Web Master	Scott Dudrick	818-687-9836
Tech. Advisor	John Wolf	818-789-6201

Meeting: 1st Tuesday of the Month, 7:00p
No host Dinner, Starting at 6:00p
Rosie's BBQ & Grill, 8930 Corbin Ave.
Northridge, Ca. 91324

Visit our Web Site: valleyv8s.org

Drive Lines is Published by
The San Fernando V8's Regional Group 40
of the Early Ford V8 Club of America
9700 Farralone, Chatsworth, Ca. 91311

The Valley V's

Past Presidents

Jim Rowe	1971
Doug Peterson	1972
Don Durkee	1973-1974
Ed Warnock	1975
John Busk	1976
Chip Werstein	1977
Stan Misraje	1978
Bill Culp	1979
Al Spencer	1980
Larry Caplan	1981
Bob Rose	1982
Don Durkee	1983
Paul Kirk	1984
Kent Lowry	1985
Dave Sanborn	1986
John Kemmerer	1987
Dudley Ochsner	1988
Jerry Jensen	1989-1990
Joe DiFatta	1991
Chuck Shubb	1992-1993
George Richards	1994
Jerry Linner	1995
Dick Smith	1996
Chuck Mair	1997
Dennie Keene	1998
Rose Golt	1999
Don Stout	2000
Steve Boskovich	2001-2002
Joe DiFatta	2003
Wendi Potter	2004
Ken Sapper	2005-2006
Stever Batesole	2007
Harry Baker	2008-2009
Dave Bergman	2010
Randy Watson	2011-2012
Steve Boskovich	2013-2014
Stan Miller	2015
Don Durkee	2015
Vasken Hagopian	2016-2018

Hello Fellow Members...

We would like to know more about You, Your Car...

So, What I would like from our members is a picture of you with your car, with a small story. (1 Paragraph)

That way, We get to learn more about our members, & we can put a face to a name & car

Please make all submissions to ether

"Drivelines" at madmodelr@aol.com, or

"Drivelines" 9700 Farralone Ave. Chatsworth, Ca. 91311

Thank You

Rob Glucksman, DL Editor



Car of the Month: Handled by Jerry Jensen, won by Jerry Case and his swell '47 Ford Sedan

Delivery. You don't see many of these! This car has some interesting history. 30 years ago, it belonged to Dick Scritchfield, a well-known name in hot rodding, the founding father of the LA Roadsters, and owner of Scritch's Auto Restoration. Like many of us, Jerry bought the '47, drove it a while, then parked it, and, it sat....and sat. Now we all know what sitting does to a car. It gets 'em a little run down and balky. But that's all changed, Jerry resurrected this fine '47, yep, he has her back on the road again. He says it's a 'work in progress', however she looks mighty fine to us, Jerry! Running the venerable 59AB flathead, it's got plenty of suds to get the job done. Congratulations, Jerry, good job of keeping the fire alive with a nice example of a mighty fine '47 Ford!

Jerry Case's 1947 Ford Sedan Delivery

March 6th Meeting

Our speaker will be Tony DeFrank, Co-Owner of California Car Cover.

Cal. Car Cov. has been a family run buisness since 1989, & is located on Desoto at Plummer

There has been many car events & swap meets held there

Bring a Guest, See you on the 6th





San Antonio Winery
737 Lamar Street
Los Angeles, CA 90031

San Antonio Winery Tour Friday, March 30, 2018
11AM @ San Antonio Wine Taste / Gift Shop
11:45 Lunch
Winery Tour Following lunch



You requested it & it's happening for the Valley Early Ford V-8 Club!
Please plan to meet at the San Antonio Winery (737 Lamar Street, Los Angeles) @ 11AM on Friday, March 30, 2018 for wine tasting, gift shopping, winery tour, and an early lunch / fellowship. We will depart the wine tasting / gift shop at approximately 11:45 to begin our dining experience at the winery café.

A personalized tour of San Antonio Winery will be provided for us by a docent following lunch. We have confirmed with administration for 15 preferred parking spots for our Early Fords near the front of the winery! The only expense we will incur is for our meal. There is a \$5.00 charge for wine tasting if so desired. We can stay as long or as little as we desire to tour the winery.

We encourage you to drive a vintage vehicle, but as always all modes of transportation are warmly welcomed! Put the date, time, & details on your calendar. A sign-up sheet will be available at the February and March meetings & info will be in the Drive Lines.

Also, you can RSVP to Rich Carter at 708-567-2393 or with e-mail at rrcarter@earthlink.net
Questions? Please feel free to ask.



R.H.FACTOR GRAPHICS
*Computer Graphics
Desktop Publishing*

Robert Glucksman
Chatsworth, Ca. 91311
office: 818-882-2002
cell: 818-618-1395
madmodelr@aol.com

For all your Pre-Press needs

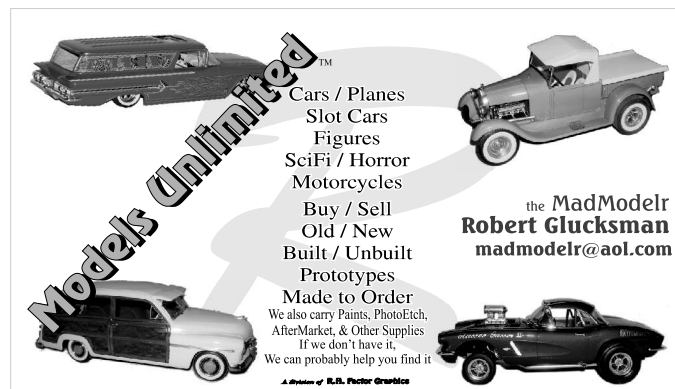

Models Unlimited™

- Cars / Planes
- Slot Cars
- Figures
- SciFi / Horror
- Motorcycles
- Buy / Sell
- Old / New
- Built / Unbuilt
- Prototypes
- Made to Order

We also carry Paints, PhotoEtch, AfterMarket, & Other Supplies
If we don't have it, We can probably help you find it

the MadModelr
Robert Glucksman
madmodelr@aol.com

A Division of R.H. Factor Graphics

"Your Ad Here"
For only \$5.00 a month,
YOU
can have your
business card ad
right here



For more details,
Please call or Email Rob at
818-882-2002, / madmodelr@aol.com
Please put "Drivelines" in the subject
Please make all payments to
"Valley V8 Club"

Chapter 40 -- San Fernando Valley V-8's Club

Monthly Meeting Minutes for Tuesday Feb. 6, 2018

7:00 pm: Meeting called to order.

President Vasken Hagopian welcomed the group to the second Club meeting of this year. He then led us in the Pledge of Allegiance.

Guest Introductions: Cliff Mickool our guest speaker and his wife Maureen were with us. Our friend Bill Katz was also present, he's becoming a very welcome regular at our Meetings!

In Valentines honor of our sweet ladies: Vasken handed out Valentines candy packages for the ladies. Very generous, there, Vasken, thanks!

Board of Directors for 2018: Vasken introduced our Club Board of Directors. He led them in the Henry Ford-based Board of Director's pledge. A big thanks to the individuals on the Board who have volunteered to serve.

Opening Comments by our President: Club business: Vasken led a discussion about increasing our Club membership. He also announced the change of our Christmas dinner to a brunch. He then mentioned the possibility of CPR training for our Club. It's a gas! Vasken showed us the gas gauge for his 'new' '34 Ford Sedan. The car has a brand new gas tank, but the sending unit doesn't work. So Vasken uses that stick to check the fuel level.

Reports from Officers:

Secretary's report - Rex Jaramillo - Everything OK.

Treasurer's report - Joan Sapper - Everything OK. Joan gave a Club financial report for year-to-date.

Editor's report - New Editor - Robert Glucksman -- Everything OK. Nice job on your first Driveline, Robert!

Tours report: - Rich Carter gave a report of the upcoming San Antonio Winery tour scheduled for Friday March 30. Rich and Lynn are doing a great job setting it up. There will be designated parking for our cars. Plans call for arriving at 11 am. There's a gift shop to browse, and a wine tasting room. At 11:45 we'll get in line for lunch. The prices are pretty reasonable: It'll cost \$10 to \$20 for a lunch meal plus tax & tip. We'll all be sitting together for lunch. Then at 1 pm we'll be offered a guided tour of the winery. It's an amazing experience, well worth the time to observe the technology and processes involved. On a side note, it's also the 100th anniversary of this winery, so they're doing some special things this year. Rich then passed a sign-up sheet around.

7:40 pm: Break called

8:00 pm: Meeting resumed

Car of the Month: Handled by Jerry Jensen, won by Jerry Case and his swell '47 Ford Sedan Delivery.

Robert Glucksman: Our new Drivelines Newsletter Editor shared an idea about the Newsletter: Include business cards in the Newsletter. There would be a small charge to have a business card added to our monthly Newsletter. However it's great advertising for business-owner members, good way to connect them with club members, in many ways, makes for a better Newsletter. Good idea, Robert!

THE EARLY FORD V-8 CLUB OF AMERICA

APPLICATION FOR MEMBERSHIP



CLUB MEMBERS - SAVE THIS FORM AND PASS IT ON TO A PROSPECTIVE CLUB MEMBER. SEE YOUR CURRENT V-8 TIMES FOR DUES INFORMATION.
www.efv8.org

U.S. MEMBERSHIP: Regular \$35; Joint \$38
Send check, money order or credit card to:
EARLY FORD V-8 CLUB
c/o Cornerstone Registration LTD
P.O. Box 1715
Maple Grove, MN 55311-6715

Visit our Website:
www.earlyfordv8.org

Please update my Membership with NEW information below. (Include only changes)

Opt-Out Option:

Keep Address Private. NOTE: Checking this box will EXCLUDE you from the published Membership Directory.
 Keep Phone Private. NOTE: Checking this box will EXCLUDE you from the published Membership Directory.

Card Number: _____ / _____ / _____ / _____ Expiration: _____ / _____ Security: _____

★ The following information will be used for your listing in the Annual Membership Roster ★

Name: _____ Spouse: _____

Address: _____

City: _____ State: _____ Zip: _____

Telephone: (_____) _____ - _____

E-mail: _____ @ _____

Early Ford V-8s owned

Year	Model	Body Style	Engine Type	Condition

EXPANDED VEHICLE LEGEND	
NOTE: Model codes evolved and changed throughout the V-8 era. Ours is a composite code system. All body types are here. Your model may share its name or code with that of another year.	
YEAR	FORD ¹
1932	18
1933	40
1934	40A
1935	48
1936	68
1937	78
1938	81A
1939	91A
1940	01A
1941	11A
1942	21A
1943	39A
1944	49A
1945	59A
1946	69A / C69
1947	79A / C79
1948	89A / C89
1949	9A / C9A
1950	0A / C0A
1951	1A / C1A
1952	BA / CBA
1953	BF / CBF
YEAR	LINCOLN ²
1932	50 / 231
1933	51 / 251
1934	52 / 271
1935	54 / 301
1936	H / 300
1937	HB / K
1938	86H / 86K
1939	96H / 96K
1940	06H
1941	16H
1942	26H
1946	66H
1947	76H
1948	8H
1949	9L / 9H
1950	0L / 0H
1951	1L / 1H
1952	2H
1953	3H
YEAR	MERCURY ³
1939	99A
1940	09A
1941	19A
1942	29A
1946	69M / C6M
1947	79M / C7M
1948	89M / C8M
1949	9M / C9M
1950	0M / C0M
1951	1M / C1M
1952	BC / CBC
1953	BG / CBG
56	-Continental Cabriolet
57	-Continental Coupe
59A	-Mainline Station Wagon
60A	-Hardtop Sport Coupe
60B	-Victoria / Hardtop Coupe-DeLuxe
70A	-Tudor Sedan
70B	-Tudor-DeLuxe
70C	-Tudor Touring / Crestliner / Tudor-Special
70D	-Tudor Touring-DeLuxe
71A	-Roadster
71S	-Sportsman
72A	-3W Coupe / Club Coupe / Sedan Coupe
72B	-3W / Club Coupe / Sedan Coupe-DeLuxe
72C	-Sport Coupe / Business Coupe / Lido
72D	-Business Coupe-DeLuxe
73A	-Fordor Sedan
73B	-Fordor-DeLuxe
73C	-Fordor Touring / Fordor-Special
73D	-Fordor Touring-DeLuxe
74A	-Victoria, 32-34 / Sport Sedan
74B	-Convertible Sedan
74C	-Convertible Touring Sedan
75A	-Phaeton
76A	-Cabriolet / Convertible Coupe
76B	-Club Cabriolet / Convertible
77A	-5W Coupe
77B	-5W Coupe-DeLuxe
77C	-5W Coupe Pickup / Coupe-Special
78A	-Sedan Delivery
78B	-Sedan Delivery-DeLuxe
79A	-Station Wagon
79B	-Station Wagon-DeLuxe
80A	-Pickup
80B	-Pickup Open Cab
80C	-Panel Delivery
80D	-Panel Delivery-DeLuxe
810	-"Jeep", GP / GPW
820	-"Seep", GPA
830	-Other Military
90A	-Ambulance / Hearse
90B	-Limousine / Taxi
90C	-School Bus
90D	-Transit Bus
92A	-Fire Engine
92B	-Paddy Wagon
93A	-Platform / Stake
93B	-COE Platform / Stake
93C	-Dump / Chassis Cab
93D	-COE Dump / Chassis Cab
94A	-Truck Tractor / Wrecker
94B	-COE Truck Tractor / Wrecker
95A	-Other
EXAMPLES:	
34 FORD Victoria = 40A74A / 49 METEOR Custom Tudor = C8A70B	
40 LINCOLN Zephyr Cpe = 06H72A / 53 MERCURY Custom Sp. Cpe = BG60A	
50 FORD Crestliner = 0A70C / 49 LINCOLN Cosmo Trn Sdn = 9H73A	
50 MONARCH Conv. = C0M76B / 47 MERCURY "114" Sdn Cpe = C7972B	
¹ FORD'S Canadian METEOR and MERCURY'S Canadian "114" are listed on the right side of this split column.	
² LINCOLN'S large Series K and large Cosmopolitan are listed on the right side of this split column.	
³ MERCURY'S Canadian MONARCH is listed on the right side of this split column.	

2018 DUES ARE DUE NOW

PLEASE SEND YOUR DUES FOR 2018 BEFORE FEBRUARY 15TH

WE PLAN TO GO TO PRINT ON THE 2015 DIRECTORY IN MARCH

SO THAT YOU WILL HAVE IT BY APRIL

DUES ARE \$35.00

PAYABLE TO: Valley V-8Es

PLEASE FILL OUT THE DUES RENEWAL FORM FOUND IN THIS ISSUE OF

THE DRIVELINES AND SEND IT ALONG WITH YOUR CHECK TO:

HARRY BAKER- 5004 ENFIELD AVENUE- ENCINO, CA. 91316

**MEMBERSHIP CHAIRMAN HARRY SAYS:
PLEASE
DON'T MAKE ME SEND THE FLYING MONKEYS AFTER YOU**

THANK YOU.



FROM THE PRESIDENT.

Happy St. Patrick's Day, Palm Sunday, Good Friday, and Passover.

Don't forget daylight savings time on March 11th. Spring forward.
Our February meeting was a lot of fun, celebrating Valentin's Day, the Board Of Directors received their award certificates for an outstanding job for 2017.

Mr. Cliff Mickool was our guest speaker, he talked about Barrett Jackson classic car auction. It is amazing how much you can learn every time about the auction process.

Starting March, it will cost you .25 cents if you forget your name badge, and Karen is the tax collector!!!!

April 7th is our first coffee and kicks at Don's, and the next one is on October 6th. Two only for the year, thank you Don, looking forward for coffee and kick some tires, maybe???

I talked about CPR demonstration, if any member can help the club by bringing a CPR specialist to demonstrate to our club members. Hands on demonstration, or information, it is very important. In case of an emergency, it great to know what to do.

Thank you Robert for volunteering for the Drive Line, the first issue was great, and I like your new ideas. (4 more years)

Car shows are at full blossom, starting March to November, I will read off from my list of swaps, and car shows at our March meeting.

Looking forward to our club tour to San Antonio Winery on Friday March 30th 11 AM. If you have not signed up, please see Rich and Lynn Carter at our March meeting. Thank you Rich and Lynn for arranging this great tour.

June 5th. is drive your Ford to the meeting month, this is nationally. Imagine all the Fords across the United States driven to the Ford meetings. 'wow"

Happy St. Patrick's Day.

Vasken Hagopian



Chapter 40 -- San Fernando Valley V-8's Club

Monthly Meeting Minutes for Tuesday Feb. 6, 2018

7:00 pm: Meeting called to order.

President Vasken Hagopian welcomed the group to the second Club meeting of this year. He then led us in the Pledge of Allegiance.

Guest Introductions: Cliff Mickool our guest speaker and his wife Maureen were with us. Our friend Bill Katz was also present, he's becoming a very welcome regular at our Meetings!

In Valentines honor of our sweet ladies: Vasken handed out Valentines candy packages for the ladies. Very generous, there, Vasken, thanks!

Board of Directors for 2018: Vasken introduced our Club Board of Directors. He led them in the Henry Ford-based Board of Director's pledge. A big thanks to the individuals on the Board who have volunteered to serve.

Opening Comments by our President: Club business: Vasken led a discussion about increasing our Club membership. He also announced the change of our Christmas dinner to a brunch. He then mentioned the possibility of CPR training for our Club. It's a gas! Vasken showed us the gas gauge for his 'new' '34 Ford Sedan. The car has a brand new gas tank, but the sending unit doesn't work. So Vasken uses that stick to check the fuel level.

Reports from Officers:

Secretary's report - Rex Jaramillo - Everything OK.

Treasurer's report - Joan Sapper - Everything OK. Joan gave a Club financial report for year-to-date.

Editor's report - New Editor - Robert Glucksman -- Everything OK. Nice job on your first Driveline, Robert!

Tours report: - Rich Carter gave a report of the upcoming San Antonio Winery tour scheduled for Friday March 30. Rich and Lynn are doing a great job setting it up. There will be designated parking for our cars. Plans call for arriving at 11 am. There's a gift shop to browse, and a wine tasting room. At 11:45 we'll get in line for lunch. The prices are pretty reasonable: It'll cost \$10 to \$20 for a lunch meal plus tax & tip. We'll all be sitting together for lunch. Then at 1 pm we'll be offered a guided tour of the winery. It's an amazing experience, well worth the time to observe the technology and processes involved. On a side note, it's also the 100th anniversary of this winery, so they're doing some special things this year. Rich then passed a sign-up sheet around.

7:40 pm: Break called

8:00 pm: Meeting resumed

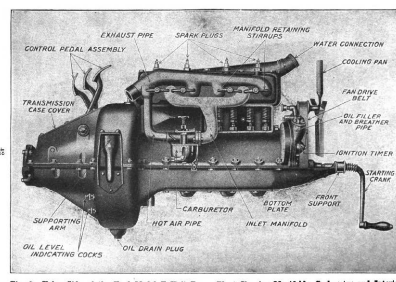
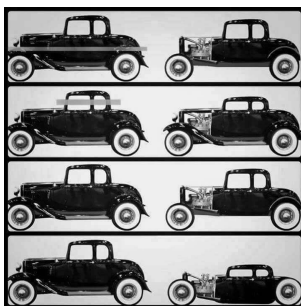

Fig. 8—Valve Side of the Ford Model 8 V8 Power Plant Showing Manifold, Carburetor and Interior of One of the Valve Spring Chambers.

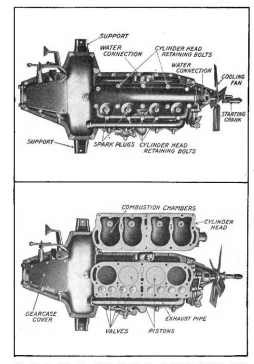

Fig. 10—Showing the Distinctive Design of the Ford Motor which Enables a Removable Cylinder Head to Permit Ready Access to the Combustion Chambers, Valves and Pistons.