

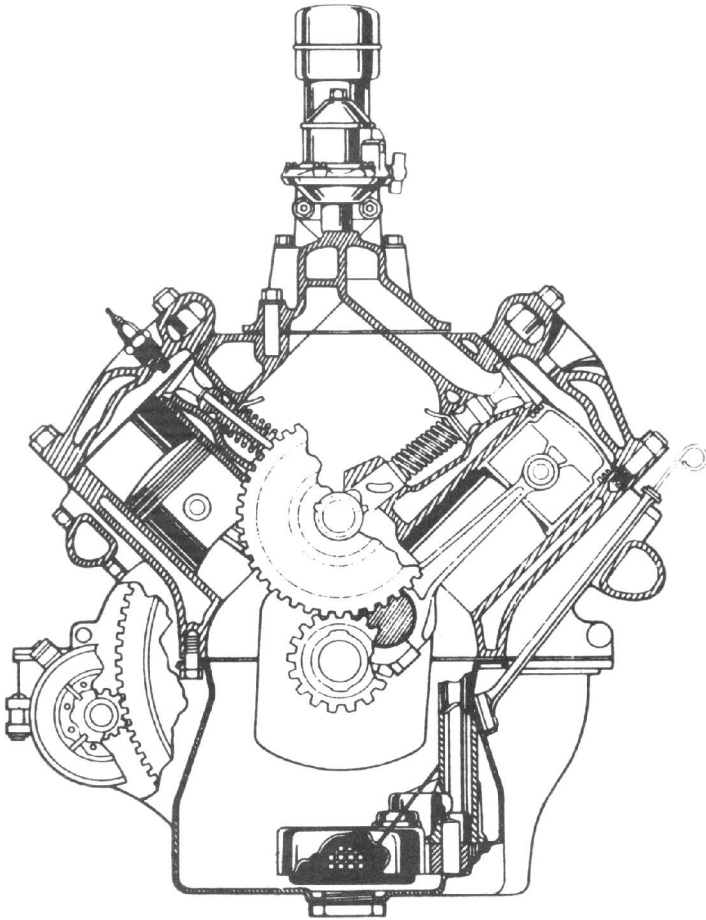

Drive Lines

Chapter #40
Our 47th Year
Visit Our Website
"valleyV8s.org"

May 2018



The Valley V8's
9700 Farralone, Chatsworth, Ca. 91311

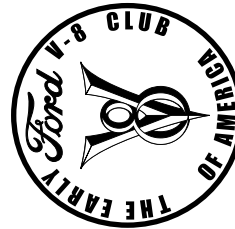

The Valley V8's

2018

President	Vaskin Hagopian	323-661-2044
Past Presidents	Don Durkee	
	Stan Miller	818-360-4812
Vice President	Steve Lehman	818-885-6938
Secretary	Rex Jaramillo	818-254-8452
Treasurer	Joan Sapper	818-249-5686
Tours	Kenney Sapper	818-249-5686
	Rich Carter	708-567-2393
Programs	Larry Caplan	818-363-2849
	Joe DiFatta	818-700-1939
Membership	Harry Baker	818-632-9017
	Joan Sapper	818-249-5686
Drive Lines	Robert Glucksman	818-618-1395
	Jim Kelley	310-795-0704
Prize Raffle	Steve Boskovich	818-341-6876
50/50	Ken Sapper	818-380-5686
Ladies / Birthdays / Sunshine	Bobby Searl	818-353-6767
Name Badge	Karen Lehman	818-885-6938
Car of the Month	Jerry Jensen	805-491-3355
Web Master	Scott Dudrick	818-687-9836
Tech. Advisor	John Wolf	818-789-6201

Meeting: 1st Tuesday of the Month, 7:00p
No host Dinner, Starting at 6:00p
Rosie's BBQ & Grill, 8930 Corbin Ave.
Northridge, Ca. 91324

Visit our Web Site: valleyv8s.org

Drive Lines is Published by
The San Fernando V8's Regional Group 40
of the Early Ford V8 Club of America
9700 Farralone, Chatsworth, Ca. 91311

The Valley V8's

Past Presidents

Jim Rowe	1971
Doug Peterson	1972
Don Durkee	1973-1974
Ed Warnock	1975
John Busk	1976
Chip Werstein	1977
Stan Misraje	1978
Bill Culp	1979
Al Spencer	1980
Larry Caplan	1981
Bob Rose	1982
Don Durkee	1983
Paul Kirk	1984
Kent Lowry	1985
Dave Sanborn	1986
John Kemmerer	1987
Dudley Ochsner	1988
Jerry Jensen	1989-1990
Joe DiFatta	1991
Chuck Shubb	1992-1993
George Richards	1994
Jerry Littner	1995
Dick Smith	1996
Chuck Mair	1997
Dennie Keene	1998
Rose Golt	1999
Don Stout	2000
Steve Boskovich	2001-2002
Joe DiFatta	2003
Wendi Potter	2004
Ken Sapper	2005-2006
Stever Batesole	2007
Harry Baker	2008-2009
Dave Bergman	2010
Randy Watson	2011-2012
Steve Boskovich	2013-2014
Stan Miller	2015
Don Durkee	2015
Vasken Hagopian	2016-2018

Program: Robert Glucksman introduced our guest, Erin Gershik. Her topic: 'The joys of restoring a car'.

Now most of us were expecting to hear an account of a collector car restoration in which everything went 'hunky dory' and the owners drove off into the sunset with a 100-point car, beautifully refurbished. On the contrary, Erin's account was very sobering. You know some of the horror stories we've all heard about the 'other guy' whose old car was captive in a shop for years and years while the bill grew and grew. Well Erin kept us spellbound, sharing about a similar scenario. Starting with her Dad: His first car back in the day was a '57 Chevy, so Erin encouraged him to have a little fun, recapture some of his youth by acquiring another '57 and fixing it up. They located a shop they felt could be trusted. Now Erin and her Dad wanted a '57 convertible, so the shop found a '57 Chevy 2-door 'post' hardtop. Their plan: Chop the top off of to make a convertible. Two years and over \$200K later, the car was still 'under construction', actually it was still a rusted hulk with a top. At this point, Erin and her Dad realized their misjudgement of the shop, so ended up hiring an attorney to salvage what they could from this ordeal. They ended up with a fraction of the money they invested in the Project, and had to spend a full day rounding up parts and towing the car from the shop. It was a grim day in their lives, as you can imagine. Then the sun, moon and stars aligned and good fortune smiled down on them: Chip Foose, noted car customizer and auto artist, heard about their plight, stepped in, and took the Project over. Turns out that the first '57 was too far gone, not to mention that chopping the top off to make a convertible is unusual. So Chip helped them purchase another '57, this one a convertible in better shape for their Project, a fresh start. Good news, they were able to salvage some of the parts for the Foose garage to use. And Chip promised that the car will be completed before the end of this year. So Erin and her Dad are in good hands, not end of story yet, but a good re-start. Wow, what a drama! How can we prevent the same from happening to us? Or for that matter, from getting ripped off in general? Using one's computer (enlisting) the help of a sympathetic grandkid to help is a good start. Type in the name of the business and do a search for 'Reviews' of the Business you're checking out. The Better Business Bureau is also a good source, a 'watchdog' for good or bad businesses. Word of mouth is another good way to locate good repair shops or businesses. And diligent checking of agreed-upon benchmark completion goals while watching expenditures is good practice. If in doubt, enlist the help of a good 'car person', one of our Club members is a good start. Erin, thank you for being straight with us and telling like it is. Not fun to re-live something like that, but it's a good lesson for us and you kept our attention. Now Erin mentioned that this car will be a driver, not a trailer queen, bravo! She also promised to bring the restored '57 Chevy to one of our Club meetings when it's completed. It's not a Ford, but knowing that it was her Dad's first car and knowing what Erin and her Dad went through, we'll welcome them with open arms. Thanks again, Erin, great presentation 'from the heart'!

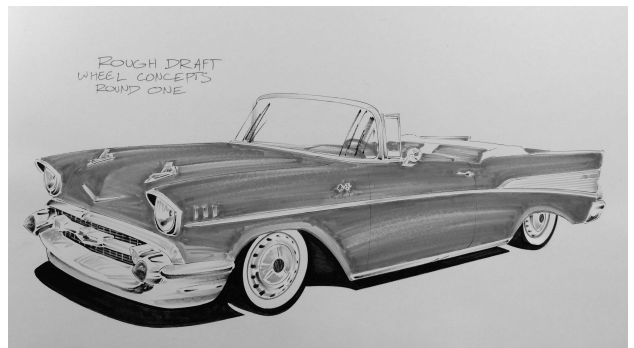

What an awesome adventure 35 Valley V-8 Early Ford members and guests enjoyed at the San Antonio Winery in downtown LA on Friday, March 30! We gathered at this family-owned jewel @ 11 AM in the previously arranged priority parking for our vintage vehicles as we kicked some tires, celebrated friendly fellowship, and connected with our happy hot rodders. Some members went inside for wine tasting and shopping in the lovely gift shop. At 11:30 we gathered at the dining room entrance to go through the line for lunch, libation etc. After selecting our entrees, we were seated together as a group in a reserved area of the spacious dining room and attended to by a very gracious and hospitable staff of servers. How welcome we felt as our lunches were served and each need attended to by superb servers!

After lunch together, we again came together for a terrific tour of the insides of the wine-making market in this family owned and operated labor of love for over 100 years. When the tour was over, some tour participants savored a wine tasting, some bought souvenirs in the gift shop and a few just celebrated this time together taking pics as we prepared to journey on to our next adventure. Thank you to all who participated and especially to those who drove their classic cars! See you down the road! By *Lynn & Rich Carter*

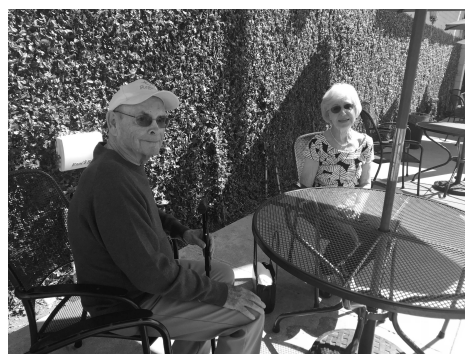



WHO WOULD DO THIS ?

Hello Fellow Members...
We would like to know more about
You, Your Car...

So, What I would like from our
members is a picture of you with your
car, with a small story. (1 Paragraph)
That way, We get to learn more about
our members, & we can put a face to
a name & car

Please make all submissions to ether
"Drivelines" at madmodelr@aol.com, or
"Drivelines" 9700 Farralone Ave.
Chatsworth, Ca. 91311

Thank You
Rob Glucksman, DL Editor

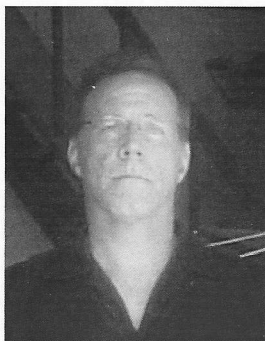

ARBONNE.
INDEPENDENT
CONSULTANT

Steven Lehman
Arbonne Independent Consultant
Consultant
23592171

Reset, Restore, Rebalance
Discover Ultimate Health,
C 818.517.1268

ArbonneForever@yahoo.com
www.stevenlehman.arbonne.com

**SPEEDWAY
ENGINEERING**



Ken Sapper
President
ken@1speedway.com
Office: 818.362.5865
Cell: 818.326.1286
Fax: 818.362.5608
13040 Bradley Avenue
Sylmar, CA. 91342
www.1speedway.com

"Your Ad Here"
For only \$5.00 a month,
YOU
can have your
business card ad
right here



For more details,
Please call or Email Rob at
818-882-2002, / madmodelr@aol.com
Please put "Drivelines" in the subject
Please make all payments to
"Valley V8 Club"



My story begins about three years ago as I began my search for a 1952-1953 Ford "Crestline" Country Squire Wagon. As a prior owner of a 1942 and 1946 Ford Wagon, I realizing that dream would be impossible with the prices in the \$75k - \$125k range. So, I began to research the very rare and obsolete '52-'53 Ford Country Squire wagons. The hybrid of the classic four-door wooden station wagon with the sleek jet age appearance of the "new all steel" 50s "top of the line", wagons began to take on a passion and appeal to me. In addition, this was a wagon that might prove to be affordable and still give me the opportunity to own a "woodie" once again.

After relentless "wanted" advertising in the V8 Times and National Woodie Club's Woodie Times, I turned up fruitless each month. As serendipity would have it, I came in contact with a fellow club member, (via good Ventura V8s friend Elwood Williams) at the 2016 Bakersfield Western National Early Ford V8 meet. "Al" indicated he had previously owned a '53 Country Squire (which he had restored to beautiful original condition) and thought the present owner, residing in Denver, CO, might be willing to part with it. We exchanged information and he said he would contact the owner, "Steve", in Denver. After two weeks I received a call from "Steve" who was very pleasant and informative about the car. Best of all, he said he would consider selling the wagon. He sent photos via email.... I was ecstatic to say the least !!! A week later I was on a plane to Denver, met "Steve" at his house, where the wagon was stored and stood in awe and disbelief at the incredible original condition. We immediately settled on an agreeable price.... I wasn't going to let this one get away. Ten days later, on December 15, 2016, my new 1953 "Crestline" Country Squire Wagon arrived at my door step within an enclosed trailer and has taken permanent residence in Ventura, CA. to be forever loved and cherished by the Cramolini family.

Car of the Month: Handled by Jerry Jensen, won by Al Mooney with his '53 Mercury Convertible. Al presently has quite a car collection, and has owned over 120 cars in his time. Now Al is a true blue oval guy, his first love being early Fords, so he presently has mostly Ford convertibles, including a clean Mustang and an early Thunderbird. Al bought this drop-top '53 Merc in 1989, and he was 53 years old at that time, interesting coincidence. It was located in Chicago, advertised in an Old Car News add. Under the hood is a healthy 255 cubic-inch stock Merc mill, pumping out 125 horsepower and twisting 218 ft/lbs of torque. Now Al wanted to make this car a driver, remember it's no lightweight, tipping the scales at 3,600 pounds. So he retrofitted it with an efficient late model GM-style power steering system and added power brakes. And check out that red paint: It was applied many years ago, and still looks mighty swell with the matching red leather interior. And Al has given parade rides to some noteworthy individuals, one of the most famous being Ronald McDonald. Congratulations, Al, nice car!



May 1st Meeting
Our speaker will be Steven Young, A fellow Car enthusiast
He will be discussing Being part of the Petersen Musuem
Bring a Guest, See you on the 1st

And now for some
"Pressing" News
 Some new laws.....

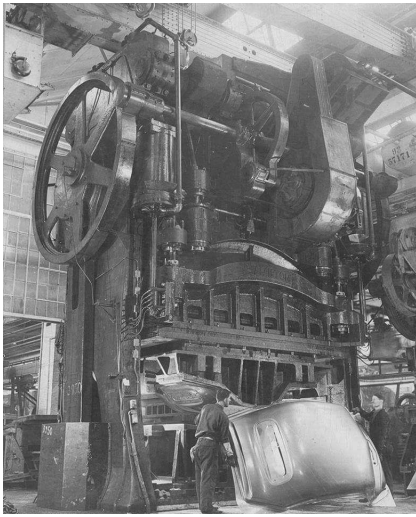

Gil & Dale, Long time friend
 to the Hot Rod & Vintage

Gil's MUFFLER
NOW IN MOORPARK!
 476 #B2 W. Los Angeles Ave. Moorpark, CA 93021
INSIDE CHRIS' AUTO CONNECTION
 Dale Schirmeister (818) 885-8867
CALL FOR AN APPOINTMENT

**5TH ANNUAL
 Rail & Road Event**
SUNDAY, APRIL 29

SAVE THE DATE!

5202 Zoo Drive in Griffith Park • www.lals.org

Vintage and classic cars, trucks, motorcycles, trains, and collectibles will be displayed at the LA Live Steamers Railroad Museum grounds in Griffith Park. Plan to bring your collectible and enjoy a day seeing a variety of other beautifully-restored vehicles from different eras and chat with their owners.

Enjoy a mile-long ride through our scenic grounds on one of our 1 1/2" scale trains. Tour Walt Disney's Carolwood Barn located in our east meadow. Buy a freshly-cooked lunch in our Kountry Kitchen, and sample a dish of "Steam Cream" premium ice cream churned by a member's 1/3-scale steam tractor.



Free to participate. Please contact event coordinator Diana Manchester at (626) 222-7499 or email dm.ad@verizon.net to reserve your space.

2018 Valley V-8 Directory

I would like to thank Mr. Jerry Littner for the
 Fantastic cover.

Also to Harvy Jacobs for the use of his 51 Ford, &
 Ginger the Pup, (No Autographs)

- May 4-5:** Edelbrock Car Show, Torrance.
- May 6:** 36th Annual Boys Town Car Show, Chatsworth.
- May 12:** Wings and War Birds & Swap, Estrella Warbird Museum, Paso Robles.
- May 13** Long Beach Swap Meet
- May 19** Canoga Park Hi. Sch. Car show
- June 2** LAPD Car Show @ Warner Center
- June 3** All GM Car Show @ Warner Center
- June 3** Pomona Swap Meet

Live Steamers and old cars: John Kemmerer made an announcement about another swell event: Sunday **April 29:** The 5th Annual Rail & Road Event, Griffith Park. Live steamers, car show, no cost to enter, no judging for the show cars. Call Diana (626)222-7499 to enter your old Ford or call John for more information.

Chapter 40 -- San Fernando Valley V-8's Club

Monthly Meeting Minutes for Tuesday Apr 3, 2018

7:00 pm: Meeting called to order

President Vasken Hagopian welcomed the group to the Meeting, then led us in the Pledge of Allegiance.

Guest Introductions: Erin Gershik, our guest speaker for the evening, was proudly introduced by her cousin Robert Glucksman.

Opening comments by our President: 2018 Grand National Meet: Is still on for June 11-15 in Dearborn, MI. Drive your V-8 Day: Saturday June 16 is still designated 'Drive your V-8 day'. For those of us who can't make it to the Nationals, Vasken gave us an alternative: He encouraged us to drive our old Fords to the June 5 Club meeting. Coffee & Kix coming up this Saturday April 7 at Don Stout's place in Chatsworth. Another car added to the collection: Vasken talked about his latest acquisition, a '78 Ford Ranchero with a 351 Cleveland mill, it pulls hard. Call Vasken if you need a truck. Fabulous Tour last week: Over 30 attendees had a great time at the San Antonio Winery. Thanks to Rich & Lynn Carter for setting it up and for the Sappers in assisting. Taxes, argh! April 10, property taxes are due. April 17, 'other' taxes are due.

Other comments: CPR education for us: Robert Glucksman announced that he is still working on this activity for our Club. It will be a great opportunity for understanding how to perform this very important task and will be coming up soon for one of our Club meetings Moving on: Vasken concluded this part of the Meeting with a round of entertaining quips and gibes

Reports from Officers:

Secretary – Rex Jaramillo: Everything OK.

Treasurer -- Joan Sapper: Everything OK. Joan gave a Club financial report.

Drive Lines Editor – Robert Glucksman: Robert reminded us of the offer to place business cards into our Club monthly Newsletter, \$5/month, cheap! 2) Remember to provide Robert with info about your old Fords. A short summary and pictures, if available, would be interesting reading for all of us.

Membership/Directory – Jerry Littner: Earlier in the meeting, Jerry handed out the new 2018 Club Directory, then as a follow up, asked if everyone had received one, great work there, Jerry!

Tours – Ken Sapper: Upcoming Car Shows: *April 15* the All-Ford Car Show, Knotts berry Farm. *June 11-15* Grand National Meet, Dearborn, MI. *June 15-16:* L.A. Roadster Show & Swap, Pomona Fairplex. (Note: The date was moved to another weekend, not Father's Day weekend). Upcoming possible tour: Ken is checking on the Oil Field Museum tour in Santa Paula. Afterwards we cruised to 'Jose's' restaurant for lunch. Sounds like a great tour, Ken will keep us posted on this.

(Monthly Meeting Minutes Continued)

Other Upcoming Car Shows: Vasken announced a few additional Car Events: *April 14-15:* Mopar Car & Swap Meet, Woodley Park. *April 21:* Home Town Country Fair, Crescenta Valley Park. *April 29:* Burbank Kiwanis Car Show, Johnny Carson Park. *May 4-5:* Edelbrock Car Show, Torrance. *May 6:* 36th Annual Boys Town Car Show, Chatsworth. *May 12:* Wings & War Birds & Swap, Estrella Warbird Museum, Paso Robles.

Live Steamers and old cars: John Kemmerer made an announcement about another swell event: Sunday *April 29:* The 5th Annual Rail & Road Event, Griffith Park. Live steamers, car show, no cost to enter, no judging for the show cars. Call Diana (626)222-7499 to enter your old Ford or call John for more information.

7:40 pm: Break called

8:00 pm: Meeting resumed

Car of the Month: Handled by Jerry Jensen, won by Al Mooney with his '53 Mercury Convertible. Congratulations, Al, nice car!

Ladies raffle: Handled by Bobby Searle. Nice plant arrangements won by Joan Sapper and Pamela Buck.

Birthdays – For April: *Apr 1-*Terry Reitz. *Apr 4-*Grace Clark. *Apr. 14-*Sharon Glucksman. *Apr. 25* Dianna Schnetlage. *Apr 27-*Steve Lehman. *Apr 28-*Harvey Jacobs.

Name Badge: Handled by Karen Lehman, won by Jerry Littner.

50/50 Drawing: Handled by Ken Sapper, won by Joan Sapper. (Not Fixed)

Program: Robert Glucksman introduced our guest, Erin Gershik. Her topic: 'The joys of restoring a car.

Raffle: Handled by Joe DiFatta. Many winners took home some nice prizes. Thanks, Joe, for handling. Note: One of the raffle prizes was a retro gas station drawing with a '40 Ford pictured, donated by John Fredericks. Thanks, John, very generous, and thanks, Steve Boskovich for acquiring the other raffle items!

Vasken: Announced next Club meeting, May 1.

8:30 pm: Meeting adjourned.

Minutes submitted by Rex Jaramillo

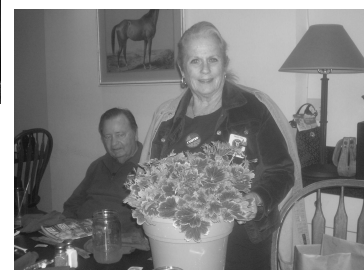

From the President.

Happy Mothers Day.

It seems that each month has numerous holidays to celebrate, and in May we have Mothers Day, Cinco de Mayo, and Memorial Day.

Memorial Day is a day to remember all the men and women that gave up their lives fighting for our freedom, the freedom that we enjoy today.

As an Army SGT. my hat is off for these brave men and women.

Coffee and Kix's at Don's was just great, the amount of people showing up to Don's has increased tremendously, and cars were wrapped around the block.

There were Fords, Chevys, Mopars, Rambler, Studebaker, Packard, etc. I have always said do not knock the other guys car, we are all classic car family, I hope this enthusiasm will not disappear in the future.

Next Coffee and Kix's is on October 6th., and that is the last one for the year. Thank you Don for sharing your treasures with us.

Don't forget your name badge, a reward is given for wearing your badge, and a penalty of .25 cents for not having one. if you lost your badge, please see Karen at next meeting.

By the time you read this letter, I/We have attended many car shows, and I/We will share them at our May meeting.

I have been visiting my 34 Ford at the upholstery shop every week, making sure everything is covered, and mounted properly. I found out that the escutcheons behind the inside handles were the wrong year, out of a 38-39 Ford, one more trip to Early Ford Store in San Dimas, just as I did a few trips when I replaced the gas tank.

Hopefully they will finish it by mid April, and I can drive it to our May meeting.

If you have not paid your membership dues, please, please do so, let us close the books for the membership for this year.

Our next meeting is on May 1st. and following one is on June 5th. Don't forget, June is drive your Ford to the meeting, this is nationally, Imagine all the beautiful Fords across the U.S.

Please bring a friend to our next meeting.

Happy Mothers Day.

Vasken Hagopian

