



Drive Lines

Chapter #40

May 22

Our 51st Year

Visit Our Website

"ValleyV8s.org"

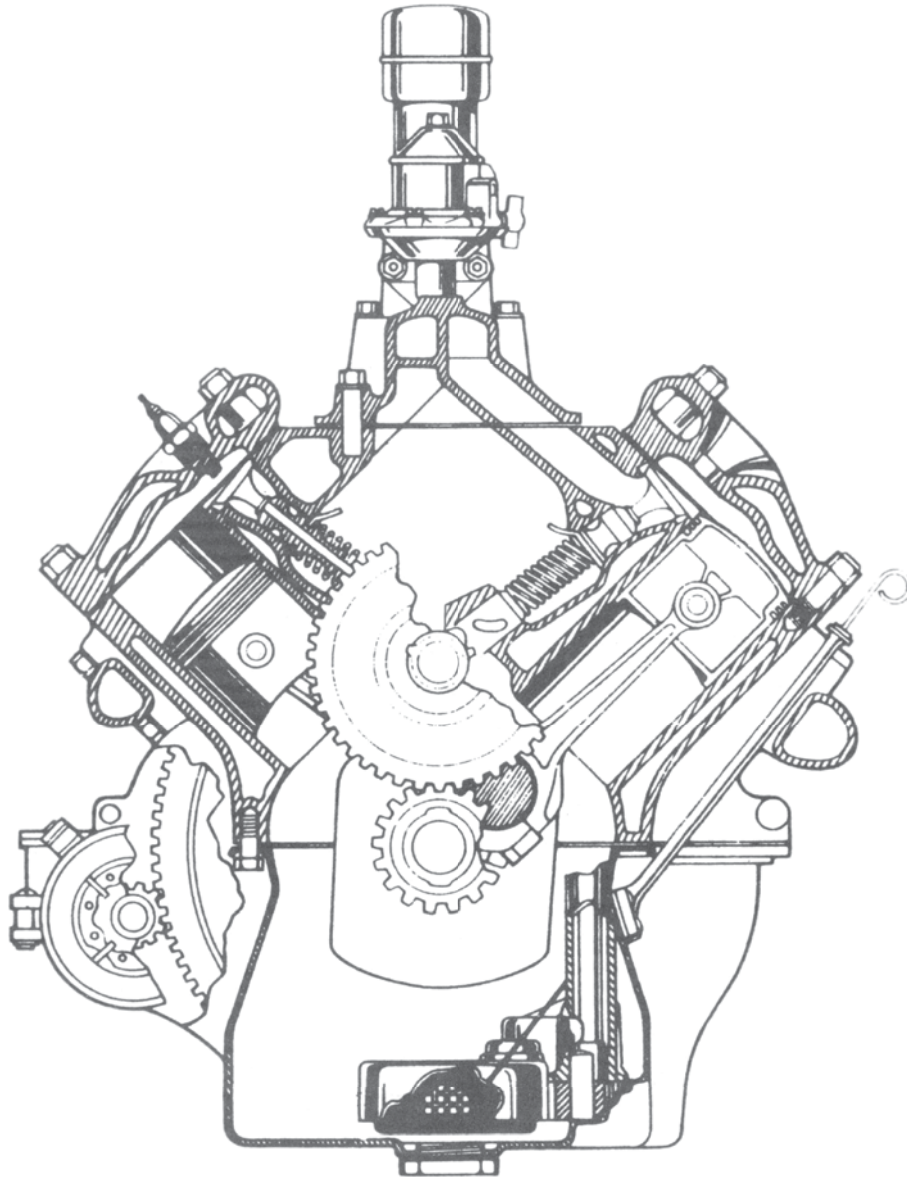

The Valley V8's
9700 Farralone, Chatsworth, Ca. 91311

The Valley V's

2022

President	Ernie Baily	805-433-5540
Past Presidents	Vaskin Hagopian	323-661-2044
Vice President	Jim Ellerbrock	818-437-0412
Secretary	Rex Jaramillo	213-706-3854
Treasurer	Joan Sapper	818-326-9685
Tours	Ernie Baily	805-433-5540
Programs	Larry Caplan	818-363-2849
	Joe DiFatta	818-700-1939
Membership	Howard Brown	818-606-0267
	Joan Sapper	818-326-9685
Drive Lines	Robert Glucksman	818-618-1395
Prize Raffle	Steve Lehman	818-885-6938
50/50	Ken Sapper	818-326-1286
Ladies / Birthdays / Sunshine	Bobby Searl	818-353-6767
Name Badge	Karen Lehman	818-885-6938
Car of the Month	Jim Ellerbrock	818-437-0412
Web Master	Scott Dudrick	818-687-9836

Meeting: 1st Tuesday of the Month, 6:00p

Visit our Web Site: valley V8s.org

Facebook: **Valley V8s**

(<https://www.facebook.com/groups/579123315803014>)

Drive Lines is Published by

The San Fernando V8's Regional Group 40

of the Early Ford V8 Club of America

9700 Farralone, Chatsworth, Ca. 91311

**For more photos of Club Events,
Please check out Web & Facebook sites**

Change of Venue

For the month of 3 MAY 22, We will be trying (take 2)

Mimi's Cafe for our May meeting

CONTINUED...

Mimi's Cafe
19710 Nordoff Pl.
Chatsworth, Ca. 91311

Past Presidents

Jim Rowe	1971
Doug Peterson	1972
Don Durkee	1973-1974
Ed Warnock	1975
John Busk	1976
Chip Werstein	1977
Stan Misraje	1978
Bill Culp	1979
Al Spencer	1980
Larry Caplan	1981
Bob Rose	1982
Don Durkee	1983
Paul Kirk	1984
Kent Lowry	1985
Dave Sanborn	1986
John Kemmerer	1987
Dudley Ochsner	1988
Jerry Jensen	1989-1990
Joe DiFatta	1991
Chuck Shubb	1992-1993
George Richards	1994
Jerry Littner	1995
Dick Smith	1996
Chuck Mair	1997
Dennis Keene	1998
Rose Golt	1999
Don Stout	2000
Steve Boskovich	2001-2002
Joe DiFatta	2003
Wendi Potter	2004
Ken Sapper	2005-2006
Steven Batesole	2007
Harry Baker	2008-2009
Dave Bergman	2010
Randy Watson	2011-2012
Steve Boskovich	2013-2014
Stan Miller	2015
Don Durkee	2015
Vasken Hagopian	2016-2018
Ernie Baily	2019-????

Our Next Meeting
3 May 22

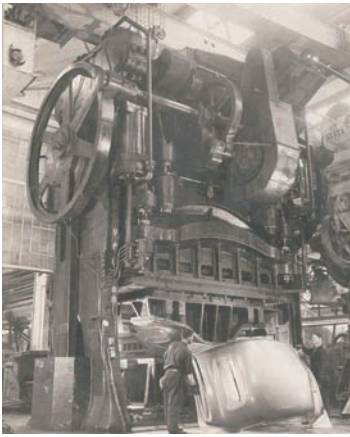

And now for some
"Pressing" News

What are you doing to stay Sane
Write Me something

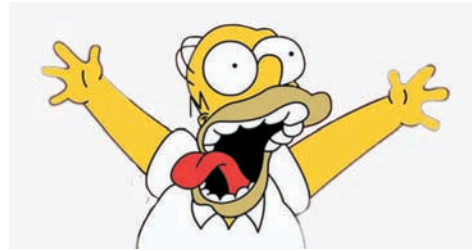

"Your Ad Here"

For only \$5.00 a month,

YOU

can have your
business card ad
right here

For more details,

Please call or Email Rob at
818-882-2002, / madmodelr@aol.com
Please put "Drivelines" in the subject
Please make all payments to
"Valley V8 Club"

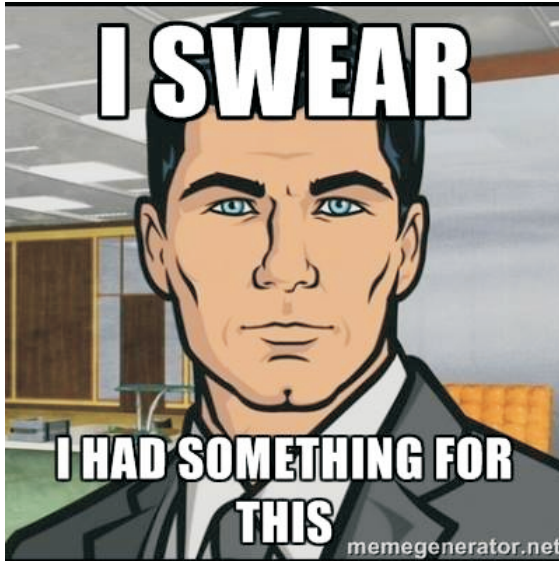

HELLO FELLOW MEMBERS

We would like to know more about You, Your Car...
So, What I would like from our members is a picture of you
with your car, with a small story. (1 Paragraph)
That way, We get to learn more about our members, & we
can put a face to a name & car

Please make all submissions to ether
"Drivelines" at madmodelr@aol.com, or
"Drivelines" 9700 Farralone Ave. Chatsworth, Ca. 91311

Thank You

Rob Glucksman, DL Editor

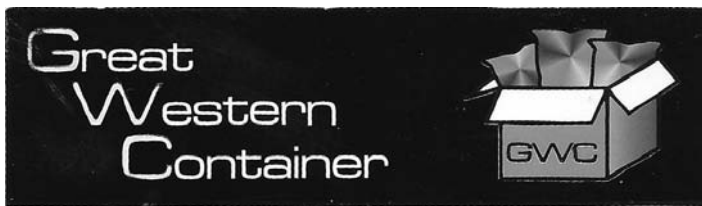

SOLUTIONS IN PACKAGING AND GRAPHIC DESIGN

Steve Boskovich

Office (818) 341-2291
Cell (818) 903-6620
Fax (818) 341-1050

P.O. Box 4074
Chatsworth CA 91313



AL MOONEY
C.F.O.

8744 REMMET AVE.
CANOGA PARK, CA 91304
(818) 998-0199
FAX (818) 341-2073

al@mooneyindustries.com

**SPEEDWAY
ENGINEERING**



Ken Sapper
President

ken@1speedway.com
Office: 818.362.5865
Cell: 818.326.1286
Fax: 818.362.5608
13040 Bradley Avenue
Sylmar, CA. 91342
www.1speedway.com

MIKE QUIROGA
President/CEO
O: 818.780.8820
F: 818.780.1713

16046 Blythe St.
Van Nuys, CA 91406



ANNIVERSARY 1972-2012

MIKE'S GOT YOU COVERED

www.mikesbuilding.com

From The President

Hello Everyone,

Well we had a pretty good meeting at Mimis Cafe, although it started out a little rocky. It turned out that our meeting didn't get on there schedule, luckily the manager for the evening was able to call in another server and they came up with a limited menu and service worked pretty good with only one cook on to handle our group. The back room was a little tight for space. So Jim and I spoke to the manager and our May meeting will be in the larger front room and should allow for better seating. We also made some changes in the Menu to allow for more choices. Also I will not be able to attend the meeting because my Wife and I are going up to the Sacramento area to visit my son in his new home. So our VP Jim Ellerbrock will take over for me. So now that we have better parking, please drive your vintage cars to the meetings. Also Howard has taken in the info in to get the Roster printed. So we will get it out to everyone as soon as it is printed.

As far as my car projects go, My Dodge is running good although the A/C quit working, so I'll have to take it back to shop before the "Hot" weather gets here. My brother and I decided to take the 56 Golden Hawk in to get the transmission rebuilt. And I'm almost done detailing the engine compartment on my brothers 56 Packard. I hope to start detailing the engine on the 58 President soon, And Jim has finished working on the radio for the 64 GT Hawk, so now we get to do the install.

Remember to drive your vintage cars to some of the up coming car events like joining us on Thursday mornings at Earl Donuts in Northridge, And Friday night at Bobs Big Boy in Northridge. And also the big Ford show "Fabulous Fords Forever" being held at Irwindale Speedway on April 24th. Well thats about all for now, so I'll see you at the June Meeting

Prez Ernie

Car of the Month

What a surprise! when the "Member's Car of the Month" was announced. The biggest surprise was that I had driven my 1962 Studebaker Gran Turismo Hawk to the meeting and not my Ford (1955 Fairlane Crown Victoria) and had my Studebaker chosen.

About three years ago, I received an email from a total stranger. This isn't unusual. This one indicated that the writer owned a '62 Studebaker Hawk which hadn't run for about 10 years. It was parked behind a shop & had been sitting there for at least a year. Now the shop owner wanted the car removed and the owner had no place to store it. Since he knew I was involved with the local Studebaker Club chapter, he thought maybe I could help him sell the car. I answered the email and asked where the car was and if I could go see it. The answer was that the car was in Chatsworth, CA (where I happen to live). Further inquiry revealed that it was only 2 miles from me! I went over to look at it and as I walked up to it I almost turned around and left. It had a rust hole about a foot long and 4 inches high near the bottom of the passenger side door, the tires were flat, there were no hub caps and of course it was really dirty. Fortunately, I decided to look in the window. I saw a lever sticking up from the floor with a little white knob (my Studebaker experience told me that lever meant it had a 4 speed manual transmission). Well, something positive! I looked a little more closely thru the filthy window and saw that it was factory equipped with air conditioning (pretty rare on a '62 Hawk). Now, I had some real interest. I walked around to the driver's side and opened the door to a musty smell, but a decent interior. I tested the clutch pedal and it felt 'normal', the brake pedal went to the floor. I went home and thought about it and decided that if I made a LOW offer for the car maybe I could fix it up a little and sell it to make a few bucks to spend on my other cars. I came up with a number (it was REALLY low) and emailed the owner. Since my offer was almost embarrassingly low, I told the owner that I didn't mean to offend or insult him, but that was all I could logically spend for the car. I didn't get a response for about a month, so I concluded that I HAD offended him and that was it. The following week I got an email that said "Your offer is accepted, you can pick up the car anytime"!! That's my story and I'm stickin' to it!!



Thanks, Howard

Chapter 40 -- San Fernando Valley V-8's Club
Monthly Meeting Minutes for
Tuesday April 5, 2022

7:00 pm: Meeting called to order. President Ernie Baily launched the meeting with the pledge of allegiance.

New Location: Tonight we met for the first time at Mimi's Café in Chatsworth, actually pretty close to Rosie's BBQ & Grillery where we used to hold our monthly meetings. Accommodations at our new restaurant were a little cramped because of mis-communication with Mimi's management. However the parking was fantastic, food was good, and the food service was excellent. And Mimi's management is going to provide a larger seating area for upcoming meetings. So in upcoming months, we plan to try Mimi's Café more to determine if it's a good fit for our Club.

Guests: Ernie Baily honored our V-8 Club member friends Rich & Lynn Carter, here to escape the unbearable winter conditions in their beloved state of Michigan.

Recent Cruise: Ernie Bailey talked about the most excellent highway and byway cruise put on by the Club. Thank you Ernie Bailey and Howard Brown for coordinating this most excellent activity. There was a good showing of club members who joined the drive to the Stage Coach Museum in Newberry Park. There was no freeway driving, the Museum car parking was very good, and there were only a few car problems. All in all, a great time was had by Club members who attended.

7:10 pm: Break called.

7:20 pm: Meeting started again.

Officer's Report: All OK

Car Shows and Events: Some new upcoming tours and activities will be discussed at the next Club Board meeting.

Car of the Month: This most prestigious award went to Howard Brown and his amazing '62 Studebaker Gran Turismo. This untouched beauty is all original, unrestored, sporty-looking, and equipped with a factory 289 V-8 engine, air conditioning, and a 4-speed transmission, making this Studebaker a rare one indeed. And Howard says it's mechanically sound, does all it was designed to do: This gem handles well, pulls nicely stoplight-to-stoplight, and stops equally well. And it's oh so swell rowing that 4-speed through the gears. Congratulations, Howard!

Lady's Raffle: Handled by Bobbie 'Grow 'em Green' Searl: Yes, the gorgeous greenery was won by a joy-filled Sandy Norris, and an equally jubilant Helen Baker.

Speaker for the Evening: Our speaker was new Club member Laurel Rosenberg. Now Laurel has the most interesting life in the land: She finds antique and classic cars for production companies that are making movies.

50/50 Raffle: Won by a prosperous Val 'Don't spend it all in one place' Ellerbrock.

Prize raffle: Many overjoyed club members walked away with some pretty amazing raffle prizes this month: Thank you President Ernie Baily for your generosity in bringing many fine items for our Raffle, including some nice power tools.

9:15 pm: Meeting adjourned.

Minutes submitted by Club secretary Rex Jaramillo.

SPEAKER

Speaker for the Evening: Our speaker was new Club member Laurel Rosenberg. Now Laurel has the most interesting life in the land: She finds antique and classic cars for production companies that are making movies. And aside from her 'Cars for the Stars' business, she's no stranger to the entertainment industry. She's played acting roles in some films as well: Love Boat, Simon & Simon, Knight Rider, Back to the Future II, Adam's Family, Get Shorty, LA Confidential to name a few. This lady's been around, see what we mean about interesting life? She also has quite a personal car collection. So what do production companies look for when hiring a car for a film? For starters, it depends, of course, on the theme and time era of the film. And car color is important as well. Average price one can expect for renting a classic car to a Production Company is around \$300 a day. And the food on set is also pretty amazing, no one goes hungry. Finally, an owner can state vehicle driving preferences: Only owner drives the car, all the way to actors and others having the OK to drive it. So if you're interested in renting and possibly seeing your collectible car in the movies, see Laurel. She can add you to her data-base. Renting our cars for this purpose could be a very interesting and entertaining venture that pays us to show off our cars. What more could we ask, a 'Win-Win'! Thank you Laurel for your talk, well done.

"Your car ought to be in the Movie's"

LaurelsPixCars.weebly.com

LaurelRosenberg@currently.com
Laurel Rosenberg

818 970-2180



Tour



WOW.....

1st off, Let Me start with I was busy shooting pics, so some of the stories I missed Sorry, however, with that being said, Lets Go.....

A BIG Thank You, goes out to Prez Ernie, & Mem. Howard

What Fun.... Great Drive..... Stagecoach Inn

Different rooms, Different Historys

As you enter, the parking lot opens to a BlackSmith's shop, & a couple of other building that I didnt check out. Down from there is a Coach house, with "OLD" coaches as well as the Tack room. Behind that room there is a Donna Fargo "Tribute" room

Another room was dedicated to Sounds, Old Wax tube Victrola, & Platers.. I can just imagine the sounds..

All of the people were awesome, knowledgeable, They even opened some other areas that were closed

Sorry, I dont have more words, But.....

Thanks, Rob / DLE



Tour

Continued....

For more pics, Please go to our Web page or our Facebook site



2 Club Donations



CAROL WHEELIS



Director

JANA GOLDSWORTHY



CATHY

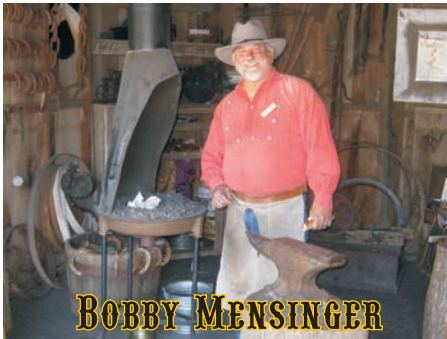

Blacksmith

BOBBY MENSINGER



LYDIJA KAZLAS

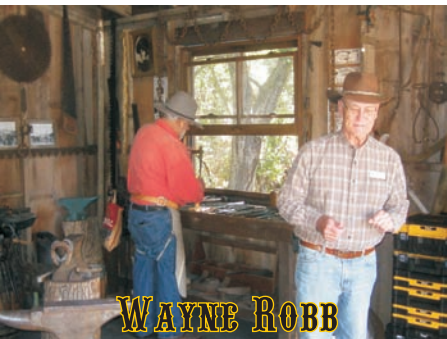

Blacksmith

WAYNE ROBB



Victrolas

PATTY LEBOW



PAT GRANING



Native Americans

IRENE SEDA

Change of Venue

For the month of 5 APR 22, We will be trying Mimi's Cafe for our April meeting

MIMI'S CAFE
19710 Nordhoff Pl.
Chatsworth, Ca. 91311

