

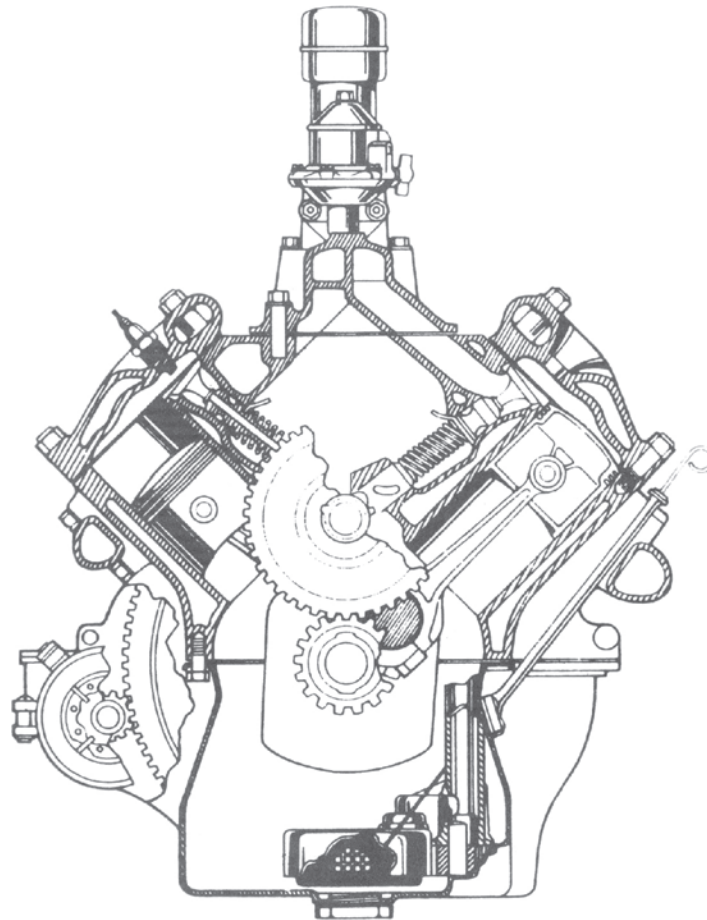

Drive Lines

Chapter #40
Our 49th Year
Visit Our Website
"ValleyV8s.org"

May 2020



The Valley V8's
9700 Farralone, Chatsworth, Ca. 91311

The Valley V's

2020

President	Ernie Baily	805-433-5540
Past Presidents	Vaskin Hagopian	323-661-2044
Vice President	Jim Ellerbrock	818-437-0412
Secretary	Rex Jaramillo	213-706-3854
Treasurer	Joan Sapper	818-249-5686
Tours	Kenney Sapper	818-249-5686
	RichCarter	708-567-2393
Programs	Larry Caplan	818-363-2849
	Joe DiFatta	818-700-1939
Membership	Howard Brown	818-606-0267
	Joan Sapper	818-249-5686
Drive Lines	Robert Glucksman	818-618-1395
Prize Raffle	Steve Lehman	818-885-6938
50/50	Ken Sapper	818-380-5686
Ladies / Birthdays / Sunshine	Bobby Searl	818-353-6767
Name Badge	Karen Lehman	818-885-6938
Car of the Month	Jim Ellerbrock	818-437-0412
Web Master	Scott Dudrick	818-687-9836
Tech. Advisor	John Wolf	818-789-6201

Meeting: 1st Tuesday of the Month, 7:00p
 No host Dinner, Starting at 6:00p
 Rosie's BBQ & Grill, 8930 Corbin Ave.
 Northridge, Ca. 91324

Visit our Web Site: valleyv8s.org
 Facebook: **Valleyv8s**
 (<https://www.facebook.com/groups/579123315803014>)

Drive Lines is Published by
 The San Fernando V8's Regional Group 40
 of the Early Ford V8 Club of America
 9700 Farralone, Chatsworth, Ca. 91311

Past Presidents

Jim Rowe	1971
Doug Peterson	1972
Don Durkee	1973-1974
Ed Warnock	1975
John Busk	1976
Chip Werstein	1977
Stan Misraje	1978
Bill Culp	1979
Al Spencer	1980
Larry Caplan	1981
Bob Rose	1982
Don Durkee	1983
Paul Kirk	1984
Kent Lowry	1985
Dave Sanborn	1986
John Kemmerer	1987
Dudley Ochsner	1988
Jerry Jensen	1989-1990
Joe DiFatta	1991
Chuck Shubb	1992-1993
George Richards	1994
Jerry Littner	1995
Dick Smith	1996
Chuck Mair	1997
Dennis Keene	1998
Rose Golt	1999
Don Stout	2000
Steve Boskovich	2001-2002
Joe DiFatta	2003
Wendi Potter	2004
Ken Sapper	2005-2006
Steven Batesole	2007
Harry Baker	2008-2009
Dave Bergman	2010
Randy Watson	2011-2012
Steve Boskovich	2013-2014
Stan Miller	2015
Don Durkee	2015
Vasken Hagopian	2016-2018
Ernie Baily	2019-????

Our Next Meeting
UNKNOWN 2020

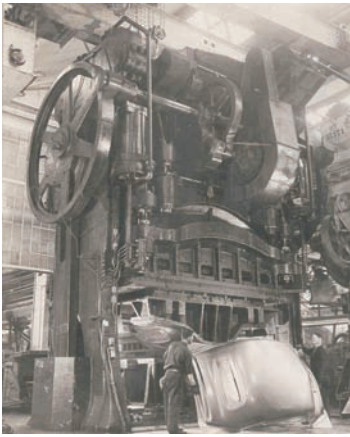

And now for some
"Pressing" News

What are you doing to stay Sane
Write Me something



"Your Ad Here"
For only \$5.00 a month,
YOU
can have your
business card ad
right here

For more details,
Please call or Email Rob at
818-882-2002, / madmodelr@aol.com
Please put "Drivelines" in the subject
Please make all payments to
"Valley V8 Club"



CHAPTER 40 -- SAN FERNANDO VALLEY V-8'S CLUB
MONTHLY MEETING MINUTES FOR
No Meeting, No Minutes.....

HELLO FELLOW MEMBERS

We would like to know more about You, Your Car...
So, What I would like from our members is a picture of you
with your car, with a small story. (1 Paragraph)
That way, We get to learn more about our members, & we
can put a face to a name & car

Please make all submissions to ether
"Drivelines" at madmodelr@aol.com, or
"Drivelines" 9700 Farralone Ave. Chatsworth, Ca. 91311

Thank You
Rob Glucksman, DL Editor

Great Western Container

SOLUTIONS IN PACKAGING AND GRAPHIC DESIGN

Steve Boskovich

Office (818) 341-2291
Cell (818) 903-6620
Fax (818) 341-1050

P.O. Box 4074
Chatsworth CA 91313

MOONEY INDUSTRIES
Precision Machining Inc.

8744 REMMET AVE.
CANOGA PARK, CA 91304
(818) 998-0199
FAX (818) 341-2073

AL MOONEY
C.F.O.
al@mooneyindustries.com

SPEEDWAY ENGINEERING



Ken Sapper
President

ken@1speedway.com
Office: 818.362.5865
Cell: 818.326.1286
Fax: 818.362.5608
13040 Bradley Avenue
Sylmar, CA. 91342
www.1speedway.com

MIKE QUIROGA
President/CEO
O: 818.780.8820
F: 818.780.1713

16046 Blythe St.
Van Nuys, CA 91406

MIKE'Sth
ROOFING & BUILDING
ANNIVERSARY 1972-2012
MIKE'S GOT YOU COVERED

www.mikesbuilding.com

NEXT MEETING???

Please keep checking our site for Updates

Member Spotlight: Jim Ellerbrock

In telling the story of the older cars that we currently own, it has a lot to do with my being a car nut growing up. Below is my car story.

History

I was raised on a farm in West-Central Iowa. Coming from the small town of Auburn of about 350, we knew everyone and they knew us. We also knew as kids, who owned what cars. This is how my interest in cars started at an early age. My Grandfather was Chevrolet man. My Dad started off with a new 1949 Chevrolet Fleetline (slanted back). He was very upset as it had a lot of mechanical issues. He then traded it for a 1951 Ford. He was a Ford man ever since. It also helped that one of his friends became a Ford dealer in the next town of Lake View). I remember our cars growing up very well. The '51 Ford was traded for a '55 Fairlane Club Coupe. That one was traded for a '62 Galaxie, and then a '66 Galaxie. and a '70 LTD. For myself, I started to drive a tractor when I was around 10 years old. I later learned to drive on my Dad's '52 International pickup (no synchronizers). As I became of legal driving age, I drove my Dad's new '66 Galaxie when he would let me. My Grandfather had purchased a new '64 Chevrolet Bel Air back in 1964. His health was declining and he passed in 1966. My Grandmother did not drive and gave me the car when I was a Junior in High School. This was my first car. The Good: a '64 Chevy 283 with 8K miles on it. The Bad: a tan 4-door sedan.

These are the older cars that I currently have:

1955 Ford Customline. (purchased in 1989). Remembering my Dad's '55 Fairlane, I saw this one listed in the paper. It was an older lady's car being sold by her grandson. It is a 2-door sedan, 272 Y-block with a Fordomatic. When I purchased it had 52K miles. It now has 67K miles. It has been repainted and interior replaced. The engine and transmission have only been serviced.

1965 Mercury Colony Park Station Wagon. (purchased in 1998). At this point in time, our kids were growing fast. We were out growing our '86 Mustang convertible. Val suggested that we look for an older Station Wagon. We found this one listed in Hemmings. It was somewhat local in Orange County. Found out that it had been turned into Chevron on their "Gas Guzzler" program. It had been rescued and was close to being sent to the crusher. We originally used it as a kid hauler. It was then used a "Picture Car" in various Movies and TV shows. In 2004 we drove it from Granada Hills (with 2 teenagers) to the Mercury Club's National Convention at the Indianapolis Speedway. We were able to take a lap. (One of the highlights of my car career).

1966 Ford Galaxie Convertible. (purchased in 2013). As I was now seriously thinking about retiring, I was also looking at convertibles. Again, looking at the Hemmings web site, I saw this '66 with 8K documented miles and it was located outside of Philadelphia. (This also reminded me of my Dad's '66). After a few conversations and photos sent by the sellers, (2 retired GM guys with this being their retirement business), I broke the golden rule and bought the car without seeing it and had it shipped. Luckily it was what they described. It even had original tires. It needed a carb rebuild, a new water pump and new tires. We try to get it out once a week or so. I've had it in numerous parades. It currently has 10K miles on it.

1969 Ford Mustang Coupe. (purchased in 1969). Val's parents bought this car new from Galpin Ford. It has always been in her family. She inherited it on the passing of her mother. The car has a 302 V-8 with an automatic. As the car had gone through a period of neglect, we decided to spruce it up by a repaint, new interior including a dash pad and a top of the engine overhaul. It has just reached 100k miles.

Although we do not have a Flathead, we really enjoy being part of the V-8 Club.

Jim and Val Ellerbrock



FROM THE EDITORS DESK

May 20

WELL, Looks like we are all still stuck inside. Now being the work I do, My life has not changed that much, HOWEVER.....I / WE are going Stir Crazy.....

A few Sundays ago, somewhat after the rains, I unwrapped the beast, & went for a drive....
Damn near no other cars on the roads, good gas prices, It could be worse
Oh Yeah,, I needed that, Cool, Fresh air, The wonderful smells mixed with that great car smell.....

I was reading an article. It focused on being "Judgmental"
It focused on how could some people be out buying "Non Essential" Items & not stay at home.

What is "non essential"... As many of you know, I am a professional Model Builder. Is buying paint essential???
What about buying coffee....

The reply was beautiful... Don't judge. What is going on in the world, has NEVER happened. We are "Locked" up. Is someone buying yarn essential, what about paint, gardening supplies, crayons?????

Answer, YES. These things are needed to help keep our sanity, to hold it together
We are not able to just go & visit, have lunches, just hang out with our Normal life

I love this club. I have had members / Friends reach out to Me in My exile just to check on Me. I have reached out & offered to get supplies for who ever needs...

Lets get thru this. Be Well My Friends

Rob, DriveLines, Editor



Please Check with one of the Board Members & Our Online pages for follow up info

More "Spare" time than usual

With our 'normal' world pretty well slowed almost to a stop by the coronavirus situation, I felt the need to get myself in gear and do something, rather than just sit in my favorite chair and read, watch TV (and occasionally fall asleep).

It took a bit of self convincing, but I finally started forcing myself to go outside and check out my 'fleet' and choose at least one car a day to work on. I'll be honest, it hasn't happened every day. Sometimes, I just can't get motivated. Fortunately on those days, I've had other 'stuff' to keep me busy. Jerry Littner and I visited the guy who prints our club directory (before the 'lockdown') and delivered the membership database to him on a memory stick. We've been working with him since, making corrections and improvements and late last week we gave him the go ahead for printing. We should be mailing the 2020 club directory to you sometime prior to April 15th.

When I have gotten outside to work, I have accomplished a few things (some non Ford and some Ford). I replaced a broken heat riser valve and exhaust 'down pipe' on my '62 Studebaker GT Hawk. The car is much quieter now! I also replaced the turn signal flasher on the same car; it wouldn't flash at idle and when it did flash it was too quiet to be heard. Some of you have seen the Studebaker at our meetings and probably noticed the gaping hole in the right side door. Well, I finally replaced that door!

Then I decided it was finally time to work on my '55 Fairlane Ford Crown Victoria. For those who don't know, I acquired the car a couple of years ago. It hadn't run in at least 20 years. After I got it home, I determined that the engine was not stuck, so at least there was a chance it might run. Between the time I got the car and now, I had the starter rebuilt (fun job to remove and replace), replaced the oil pressure sending switch and bulb so I would know if I had oil pressure and replaced the battery and cables. At that point the starter would crank the engine but it wouldn't start. This week, to enable the 6 volt car to crank faster while I tried to resuscitate it, I disconnected the car's electrical system from the battery and temporarily installed a 12 volt battery. That meant I could crank the car faster without impacting (destroying) any of the car's 6 volt components. Then I went on to prove that I had a spark. After removing the distributor (not a lot of fun on a Y-block Ford V8), I cleaned and gapped the points and replaced the broken primary wire to the points. I poured some gas into the carb, cranked the engine and it sputtered a couple of times! Success, it actually tried to run. I quickly determined that the carburetor was not gonna be of much use until I could rebuild it, so I put out a couple of calls to fellow Valley V8s club members looking for a 2 barrel carburetor I could borrow. Don Stout came thru (Thanks Don!) so I quickly went to Don's house and picked up a 2 barrel Stromberg. After undoing a few 'Mickey Mouse' things a previous owner had done, I installed Don's carburetor and poured a little gas into it. I hit the starter and the engine fired and ran a for couple of seconds, but the temporary oil pressure gauge I had installed under the hood for observation, showed no oil pressure, so I quickly shut it off. Next step will be to remove the cover from the oil pump and see if the pump gears turn when the engine is cranked. I think the problem is probably that the pump 'lost its prime' and I'll have to pack it with Vaseline to get it to pump. Stayed tuned for Crown Victoria breaking news!

Howard Brown, / Membership

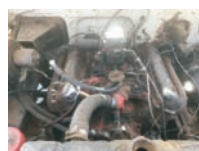

From The President

Hello, Everyone

Well, We are in some unknown times! It looks like our May meeting is canceled and I'm assuming everyone has been staying home and only going out for necessities. Plus we have had the rain too! I can't even go out and do yardwork! I also want to thank our VP Jim Ellerbrock for his "Members Profile" this month. Do we have any volunteers for next month?

Lets see who has birthdays in May:(According to my list) Happy Birthday to all!

May 1st Leslie Nuccitelli
2nd Patty Schneider
3rd Bobbie Searl
5th Margaret Russell
9th Jean Knapp
13th Brandon Jacobson
15th John Fredricks
17th Rich Carter
Sue Boskovich
19th Paul Kirk
27th Helen Baker
28th Zita Goeschi
31st Judy Shubb

I have just received some news that Al Mooney has just been placed in the hospital for pneumonia, not sure if is connected to the Covid19 virus.

I have received a email from the National Club, they are suggesting to the regional clubs to try to do something to raise the sprits of the membership by doing a "Driving Tour". Creating a loop tour the members can get their Early Fords out and do a tour where everyone stays in their car and does a country drive scenic tour. it would bring enjoyment to the members as well as the people who see the tour going bye. Once these tours start they can be called "Mystery Cruises", where we hand out printed directions and follow them to set location and even give descriptions of the historic site as we go by them. I remember talking to Ken & Joanie last year about doing some thing like this (Corvair Clubs Poppy tour). I found a great web site called "Mad Maps" at <http://www.madmaps.com> , check it out! How does this idea sound? Any Ideas where to go? Drop me a email with your Ideas.

Everybody hang in there, and we'll see you at the June meeting!

Prez. Ernie

P.S.

I thought I would include a couple of pictures of my brothers Studebakers that I have been working on and talking about for so long!

