

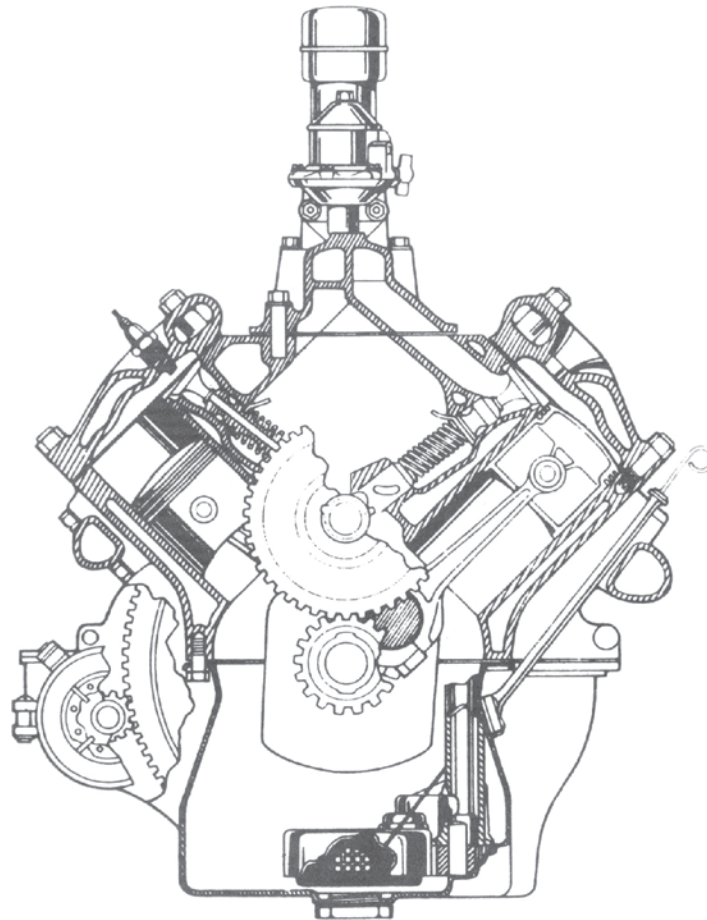

Drive Lines

Chapter #40
Our 49th Year
Visit Our Website
"ValleyV8s.org"

JUNE 2020



The Valley V8's
9700 Farralone, Chatsworth, Ca. 91311

The Valley V's

2020

President	Ernie Baily	805-433-5540
Past Presidents	Vaskin Hagopian	323-661-2044
Vice President	Jim Ellerbrock	818-437-0412
Secretary	Rex Jaramillo	213-706-3854
Treasurer	Joan Sapper	818-249-5686
Tours	Kenney Sapper	818-249-5686
	RichCarter	708-567-2393
Programs	Larry Caplan	818-363-2849
	Joe DiFatta	818-700-1939
Membership	Howard Brown	818-606-0267
	Joan Sapper	818-249-5686
Drive Lines	Robert Glucksman	818-618-1395
Prize Raffle	Steve Lehman	818-885-6938
50/50	Ken Sapper	818-380-5686
Ladies / Birthdays / Sunshine	Bobby Searl	818-353-6767
Name Badge	Karen Lehman	818-885-6938
Car of the Month	Jim Ellerbrock	818-437-0412
Web Master	Scott Dudrick	818-687-9836
Tech. Advisor	John Wolf	818-789-6201

Meeting: 1st Tuesday of the Month, 7:00p
 No host Dinner, Starting at 6:00p
 Rosie's BBQ & Grill, 8930 Corbin Ave.
 Northridge, Ca. 91324

Visit our Web Site: valleyv8s.org
 Facebook: **Valleyv8s**
 (<https://www.facebook.com/groups/579123315803014>)

Drive Lines is Published by
 The San Fernando V8's Regional Group 40
 of the Early Ford V8 Club of America
 9700 Farralone, Chatsworth, Ca. 91311

Past Presidents

Jim Rowe	1971
Doug Peterson	1972
Don Durkee	1973-1974
Ed Warnock	1975
John Busk	1976
Chip Werstein	1977
Stan Misraje	1978
Bill Culp	1979
Al Spencer	1980
Larry Caplan	1981
Bob Rose	1982
Don Durkee	1983
Paul Kirk	1984
Kent Lowry	1985
Dave Sanborn	1986
John Kemmerer	1987
Dudley Ochsner	1988
Jerry Jensen	1989-1990
Joe DiFatta	1991
Chuck Shubb	1992-1993
George Richards	1994
Jerry Littner	1995
Dick Smith	1996
Chuck Mair	1997
Dennis Keene	1998
Rose Golt	1999
Don Stout	2000
Steve Boskovich	2001-2002
Joe DiFatta	2003
Wendi Potter	2004
Ken Sapper	2005-2006
Steven Batesole	2007
Harry Baker	2008-2009
Dave Bergman	2010
Randy Watson	2011-2012
Steve Boskovich	2013-2014
Stan Miller	2015
Don Durkee	2015
Vasken Hagopian	2016-2018
Ernie Baily	2019-????

Our Next Meeting
UNKNOWN 2020

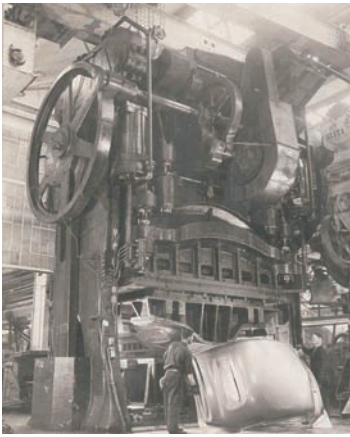

And now for some
"Pressing" News

**What are you doing to stay Sane
Write Me something**



"Your Ad Here"
For only \$5.00 a month,
YOU
can have your
business card ad
right here

For more details,
Please call or Email Rob at
818-882-2002, / madmodelr@aol.com
Please put "Drivelines" in the subject
Please make all payments to
"Valley V8 Club"



**CHAPTER 40 -- SAN FERNANDO VALLEY V-8'S CLUB
MONTHLY MEETING MINUTES FOR
No Meeting, No Minutes.....**

HELLO FELLOW MEMBERS

We would like to know more about You, Your Car...
So, What I would like from our members is a picture of you
with your car, with a small story. (1 Paragraph)
That way, We get to learn more about our members, & we
can put a face to a name & car

Please make all submissions to ether
"Drivelines" at madmodelr@aol.com, or
"Drivelines" 9700 Farralone Ave. Chatsworth, Ca. 91311

Thank You
Rob Glucksman, DL Editor

Great Western Container

SOLUTIONS IN PACKAGING AND GRAPHIC DESIGN

Steve Boskovich

Office (818) 341-2291
Cell (818) 903-6620
Fax (818) 341-1050

P.O. Box 4074
Chatsworth CA 91313



8744 REMMET AVE.
CANOGA PARK, CA 91304
(818) 998-0199
FAX (818) 341-2073

AL MOONEY
C.F.O.

al@mooneyindustries.com

**SPEEDWAY
ENGINEERING**



Ken Sapper
President

ken@1speedway.com
Office: 818.362.5865
Cell: 818.326.1286
Fax: 818.362.5608
13040 Bradley Avenue
Sylmar, CA. 91342
www.1speedway.com

MIKE QUIROGA
President/CEO
O: 818.780.8820
F: 818.780.1713

16046 Blythe St.
Van Nuys, CA 91406



ANNIVERSARY 1972-2012

MIKE'S GOT YOU COVERED

www.mikesbuilding.com



2020 National News

Early Ford V-8 Club of America

May II



Drive Your V-8 Day



San Diego RG #19 on Drive your V-8 Day 2019

Did you take your V-8 out on "Drive Your V-8 Day" 2020?

Did you take a picture?

Don't forget to submit the best ones (not more than four, please!) along with a short description of what you did or what the photo(s) depict to the V-8 TIMES. E-Mail your pictures (put "Drive Your V-8 Day" in the subject line) by July 15 to v8times@cox.net or mail them to P.O. Box 16630, San Diego, CA 92116.

Your photos and captions may appear in the V-8 TIMES. It could be your chance for a cover shot!

Your Membership Info Up To Date?

Was your membership info in the 2020 Membership correct?

If not, you need to contact Cornerstone to update it. You can call (866) 427-7583 or send in changes using the membership form that comes with your V-8 TIMES. Indicate it is an update to your membership info.

If you're a registered user at the club website - www.efv8.org - you can access your membership info and make the changes yourself.

Bottomline - you're responsible for keeping your membership info up to date.

Don't Delay - it today!

**V-8 Club
The Online Store
Books & Accesories**

**The Forum
Restoration Help
www.efv8.org**



*The Good Humor Man delivers cold treats on these hot days in this 1949 Ford truck. EARLY FORD V-8 CLUB ON THE ROAD, St. Louis RG #124
Mary Rogers, Editor*

Harbor Freight Jack Stand Recall



The Harbor Freight jack stands that we've all bought, borrowed or seen in our friends' garages are being recalled due to a risk of collapsing under load. Go check yours immediately.

The recall document says that the problem could affect more than 450,000 6-ton jack stands produced between 2013 and 2019 and nearly 1.3 million 3-ton jack stands produced between 2012 and 2020.

These jack stands were sold

under the Pittsburg brand name, and can be identified by item numbers 56371 or 61196 on 3-ton models, and 61197 on 6-ton models.

Harbor Freight urges anybody in possession of affected jack stands to return them to the store in exchange for a gift card equal to the price of the stands. Any unsold jack stands covered by the recall have been removed from stores.

Check on your buddies and spread the word around—these jack stands are ubiquitous, and a failure like this could be fatal.

Club Books

While you're locked down, this is a good time to check out the Club books to help with your restoration.

If you're having your V-8 judged at a meet, you can challenge a deduction by using the Club book on your car as a reference.

FORD FACT

Henry Ford and Thomas Edison were lifelong friends.

As requested by Ford, Thomas Edison's son captured Edison's last exhale in a test tube and sealed it with a cork. Ford kept the tube as a memorial to Edison's "life and breath."

Presented by the Early Ford V-8 Foundation

**For The Latest News About
The V-8 Club
Visit The Website
www.efv8.org**

NEXT MEETING???

Please keep checking our site for Updates

WALKING

with Val and Jim Ellerbrock

One of the things that Val and I have been doing for exercise is walking around our Granada Hills neighborhood. An advantage of walking as opposed to driving by at 30 miles per hour is that you notice a lot more details. This includes older cars that are on side yards as well as in open garages. We have been walking in different directions from our house and come up with some interesting finds. Here are some of them.

One of our bigger finds is a storage garage near the top of Louise Ave. These buildings have been there for a long time and are part of an old Estate. When we were walking by, a gentleman (Paul) was struggling to unload two heavy pieces of iron from his pickup. I volunteered to help him move them into the garage. He stated that they were to be installed as side rail replacements for his '57 Bentley. After a conversation explaining that we were also car people, he invited us in to look around. He explained that the garage was strictly used for rental storage to multiple people over the years. There had been "movie cars and trucks" stored there and in adjoining buildings. Many old lanterns and license plates were hanging from the ceiling. Paul's Bentley was a beautiful car. Hard to believe that it needed side rail replacement. Also, in that area of the garage was an early 60s Rolls Royce and an older 1940s Packard limousine. The one that caught my eye was a 1940 Ford coupe. It was an original car in light green with an original interior. I thought I saw an "Early Ford V-8 Club" emblem on the rear. I told Paul that I knew of quite a few people that would be interested in the car, but he knew that the car was definitely not for sale.

Note: I was later telling Joe DiFatta about this place. He said that some of the club members had been there on tour a few years ago.

We also were walking in a neighborhood west of us. In one open garage was a '60 Pontiac. A few houses down sitting in the driveway was a '61 Chrysler station wagon, a mid 60s Toyota Land Rover and a '61 Ford Galaxie Starliner. Also on the same street a few blocks down was a '63 Bonneville and a slightly rusted '63 Ford Fairlane Sport Coupe.

I have finally been working on my '55 Ford Fairlane Crown Victoria. I have been using a borrowed carburetor (from Don Stout-Thanks Don!). The car now runs. I just rebuilt the original carburetor and installed it. I just had the gas tank chemically cleaned and a leak repaired. I have had help from our President, Ernie Baily and our Vice-President, Jim Ellerbrock (since they are Ford guys and my recent Ford experience is somewhat limited). I have installed the gas tank and connected everything (fuel sender, vent hose and outgoing fuel line). Now, I'll put a couple of gallons of gas in it, verify the gas gauge works correctly and start the engine to see if the fuel pump will bring gas to the carburetor. I also need to replace the water pump so I can run the car long enough to see if the automatic transmission works (after 'resting' 25 years). If the transmission works, it's on to 'refreshing' the brakes. This is a significant project, but I'm having a good time with it, especially with all the support I'm getting from club members. One of these days (I hope very soon) we'll start having our meetings again and maybe I'll be ready to bring the Crown Vicky to a meeting.

Howard Brown, Membership



From The President

Hello,

Thanks to Jims email I almost forgot to do a June edition of the Presidents message. First of all I want to say that it is great to hear that our own Al Mooney is doing well and continuing to get better. I hope all of the rest of our V8 Club family is doing well. I know I have been doing things like working on brothers two Studebakers which are working just great. I even was able to help our one Howard Brown with his 56 Studebaker Golden Hawk(bleeding the brakes and taking the gas tank for his 55 Ford Crown Victoria to the stripper and then to the repair shop. It shouldn't be to long before we see Howard driving it to our meetings.

I'm starting to plan a driving tour that I would like to do towards the end of the month. More info to Follow! However there are a couple of car shows that might be fun to see. One is the(8th Annual Vintage Trailer Show") at Murphys Auto Museum at 1930 Eastman Ave. Oxnard, Ca. on June 20th. Also there is a Fathers Day Car Show called "Cruisin Brea Classic Car Show" on Sunday June 21st. on Brich St.-Brea Downtown.

As you know we are not sure of when we will be able to hold a actual meeting. So I just find a reason to take my Vintage cars for a drive. About two weeks ago my wife and I took a back roads drive with my 48 Plymouth out to the Underwood Farms open air market for some fresh Fruit and vegetables. It was a nice drive and I got a lot of thumbs Up!

All I can say is Hang In There!

Your Prez, Ernie

FROM THE EDITORS DESK

May 30

WELL, Looks like we are all STILL stuck inside.

Let me first start with an apology to every one. I must admit that this is starting to get to Me, & I have been keeping tom Myself, avoiding everything, getting burnt out...

I have thrown Myself into My work & by the time I should be working on your newsletter, I'm fried.....

I'm sorry, I will do better....

Thank You

Lets get thru this. Be Well My Friends

Rob, DriveLines, Editor



Please Check with one of the Board Members & Our Online pages for follow up info

Member News.....

“Good News, bad News”

Well, to start, Earlier this month, Mr. Rex Jaramillo’s Mother passed away

Sincere Condolences

= = = = =

Many do not know, However, Our own Mr Al Mooney Has been fighting the “corona”.....BUT, He IS recovering, & it sounds like he’s doing well