



Drive Lines

Chapter #40

FEB 22

Our 51st Year

Visit Our Website

"ValleyV8s.org"

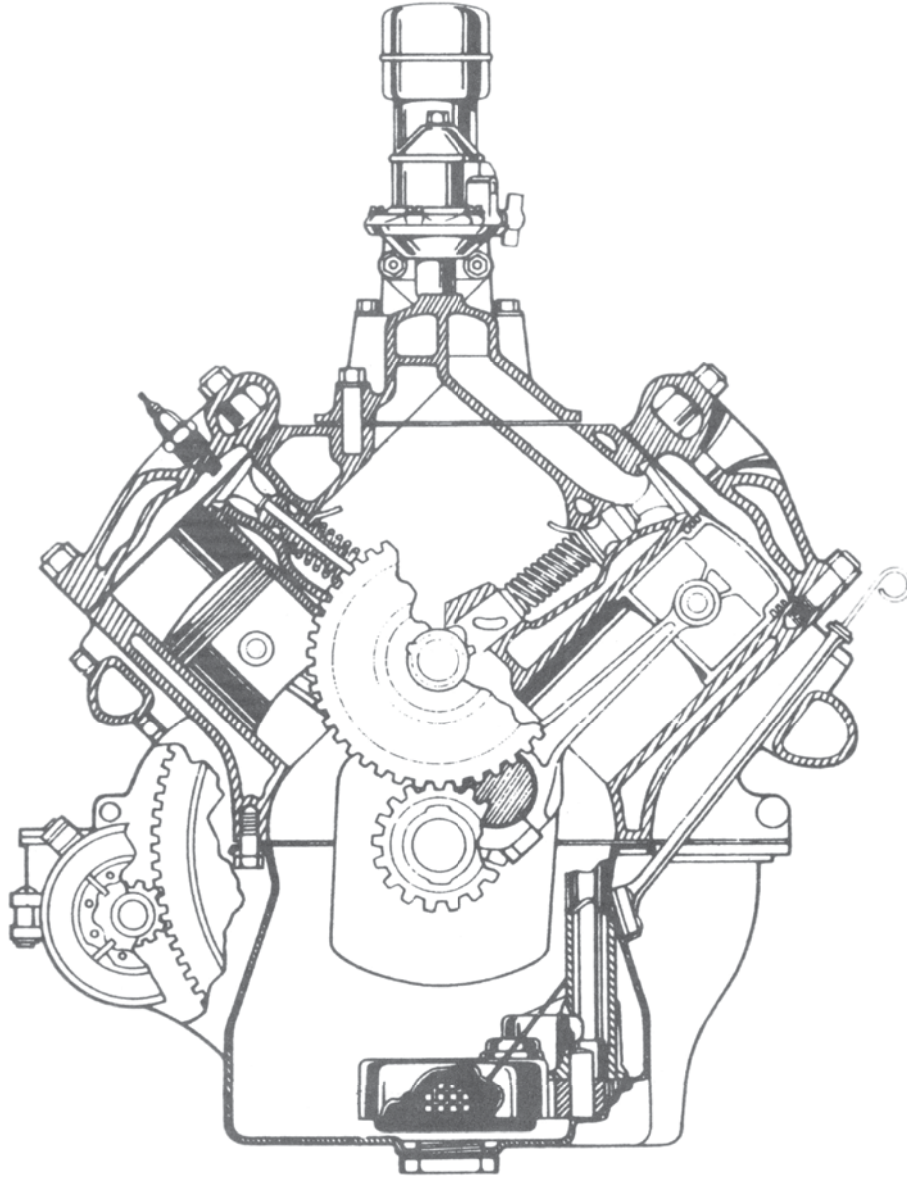

The Valley V8's
9700 Farralone, Chatsworth, Ca. 91311

The Valley V's

2022

President	Ernie Baily	805-433-5540	<i>Past Presidents</i>	
Past Presidents	Vaskin Hagopian	323-661-2044	Jim Rowe	1971
Vice President	Jim Ellerbrock	818-437-0412	Doug Peterson	1972
Secretary	Rex Jaramillo	213-706-3854	Don Durkee	1973-1974
Treasurer	Joan Sapper	818-326-9685	Ed Warnock	1975
Tours	Rich Carter	708-567-2393	John Busk	1976
Programs	Larry Caplan	818-363-2849	Chip Werstein	1977
	Joe DiFatta	818-700-1939	Stan Misraje	1978
Membership	Howard Brown	818-606-0267	Bill Culp	1979
	Joan Sapper	818-326-9685	Al Spencer	1980
Drive Lines	Robert Glucksman	818-618-1395	Larry Caplan	1981
Prize Raffle	Steve Lehman	818-885-6938	Bob Rose	1982
50/50	Ken Sapper	818-326-1286	Don Durkee	1983
Ladies / Birthdays / Sunshine	Bobby Searl	818-353-6767	Paul Kirk	1984
Name Badge	Karen Lehman	818-885-6938	Kent Lowry	1985
Car of the Month	Jim Ellerbrock	818-437-0412	Dave Sanborn	1986
Web Master	Scott Dudrick	818-687-9836	John Kemmerer	1987
			Dudley Ochsner	1988
			Jerry Jensen	1989-1990
			Joe DiFatta	1991
			Chuck Shubb	1992-1993
			George Richards	1994
			Jerry Littner	1995
			Dick Smith	1996
			Chuck Mair	1997
			Dennis Keene	1998
			Rose Golt	1999
			Don Stout	2000
			Steve Boskovich	2001-2002
			Joe DiFatta	2003
			Wendi Potter	2004
			Ken Sapper	2005-2006
			Steven Batesole	2007
			Harry Baker	2008-2009
			Dave Bergman	2010
			Randy Watson	2011-2012
			Steve Boskovich	2013-2014
			Stan Miller	2015
			Don Durkee	2015
			Vasken Hagopian	2016-2018
			Ernie Baily	2019-????

Meeting: 1st Tuesday of the Month, 6:00p

Visit our Web Site: [valley V8s.org](http://valleyV8s.org)

Facebook: **Valley V8s**

(<https://www.facebook.com/groups/579123315803014>)

Drive Lines is Published by

The San Fernando V8's Regional Group 40

of the Early Ford V8 Club of America

9700 Farralone, Chatsworth, Ca. 91311

**For more photos of Club Events,
Please check out Web & Facebook sites**

Meeting at
ROSIES
8930 Corbin Ave,
Northridge, CA 91324

Our Next Meeting
1 Feb 22

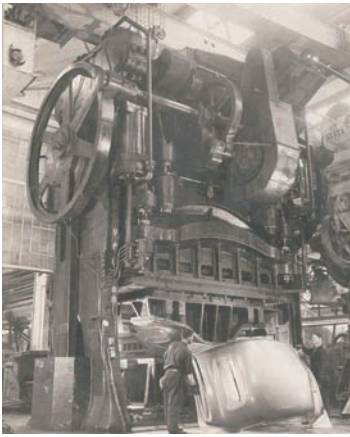

And now for some
"Pressing" News

What are you doing to stay Sane
Write Me something

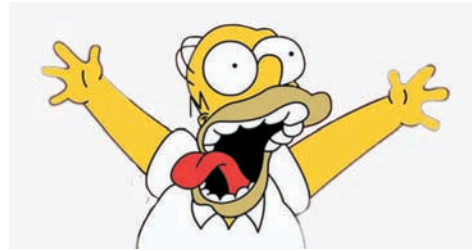

"Your Ad Here"
For only \$5.00 a month,
YOU
can have your
business card ad
right here

For more details,
Please call or Email Rob at
818-882-2002, / madmodelr@aol.com
Please put "Drivelines" in the subject
Please make all payments to
"Valley V8 Club"

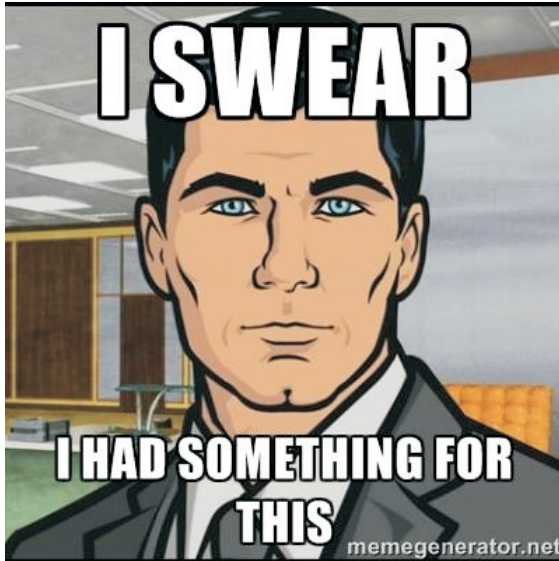

HELLO FELLOW MEMBERS

We would like to know more about You, Your Car...
So, What I would like from our members is a picture of you
with your car, with a small story. (1 Paragraph)
That way, We get to learn more about our members, & we
can put a face to a name & car

Please make all submissions to ether
"Drivelines" at madmodelr@aol.com, or
"Drivelines" 9700 Farralone Ave. Chatsworth, Ca. 91311

Thank You

Rob Glucksman, DL Editor



SOLUTIONS IN PACKAGING AND GRAPHIC DESIGN

Steve Boskovich

Office (818) 341-2291
Cell (818) 903-6620
Fax (818) 341-1050

P.O. Box 4074
Chatsworth CA 91313



AL MOONEY
C.F.O.

8744 REMMET AVE.
CANOGA PARK, CA 91304
(818) 998-0199
FAX (818) 341-2073

al@mooneyindustries.com

SPEEDWAY
ENGINEERING



Ken Sapper
President

ken@1speedway.com
Office: 818.362.5865
Cell: 818.326.1286
Fax: 818.362.5608
13040 Bradley Avenue
Sylmar, CA. 91342
www.1speedway.com

MIKE QUIROGA
President/CEO
O: 818.780.8820
F: 818.780.1713

16046 Blythe St.
Van Nuys, CA 91406



ANNIVERSARY 1972-2012

MIKE'S GOT YOU COVERED

www.mikesbuilding.com

From The President

Well Hello Everyone,

Happy New Year! Hope every one had a Merry Xmas! Mine was pretty good. My Niece and her kids (on my wifes side) were not able to come over and do a Christmas celebration due to the fact that my Great Nephew came down with Covid. So we are going to leave some of the Xmas decorations up for a belated Xmas later. Also on a good note, I had the opportunity to drive Santa to a local neighborhood event supporting the Royal High School Choir. So I dressed up my 48 Plymouth and drove him on Dec 17th Friday evening. I had my Niece Laura and my Great Niece Gabriella ride with us, it was great fun!

Due to the rain I didn't get much time to works on my brothers Studebakers and Packard, but I was able to replace the vent window handle and repair the exhaust tip that had blew off when I was attempting to start it one morning. Opps!

I'm hoping to come up with tour Ideas as well as Speaker ideas. So if you have any ideas please send them to me. I'm still planning on having a board meeting some time in January to kick off the new years planning.

After some considerable debate I have decided that we should cancel the Jan meeting. It seems that the news reports suggest that surge will be short lived. So rather than making a long term decision, I decided to just cancel this month meeting and remain open in regards to next month meeting.

Hope to see you all at our next live meeting!

Prez Ernie

I would like to add to my president message a comment about our clubs Membership renewal. Please send in your renewal for both the National and our Regional membership at your earliest convenience. I'm attaching the new National Club membership form witch includes their new Digital option.

NEEDED FILLER, SO.....JUST FOR FUN



**The Valley V-8's
2022 Membership Application & Renewal Form**

In order to continue to receive the Drivelines and remain in the roster

Or to join our club

Please renew your membership by February 15, 2022

Name: _____ **Birthday Month:** _____ **Day:** _____

Spouse: _____ **Birthday Month:** _____ **Day:** _____

Address: _____ **City:** _____ **State & Zip** _____

Phones - Home _____ **Cell** _____ **Work** _____

Email: _____

Occupation: _____

Year Joined: _____

Early Ford V-8 Vehicle(s) Owned - if same as prior year write "NO CHANGE"

<u>Year</u>	<u>Make</u>	<u>Model</u>	<u>Body</u>	<u>Style</u>

For Regional Membership: Send a \$35.00 check - payable to: Valley V-8's

**Mail check to: Valley V8's C/O Howard Brown, 20036 Tuba St. Chatsworth, Ca.
91311**

If you have any questions please call 818-606-0267 Email: brngarage@gmail.com

NOTE: For us to meet insurance requirements, a Regional Group Member MUST also be a member of the Early Ford V-8 Club of America. Minimum membership is \$35.00 per year. Please contact me for mailing information or <http://www.earlyfordv8.org>



Dear Friend and Early V-8 Ford Enthusiast,

The countdown to our annual Scottsdale Auction is now on, and the Worldwide Auctioneers team is gearing up for another great event in the desert during Arizona Car Week. We are excited to be offering one of the most detailed and correct early Ford V-8 collections to come to market as a highlight of this year's sale, with 35 great cars from The Ron Thorne Collection slated to go under the hammer, completely without reserve.

As fellow enthusiasts, we want to personally invite you to the Scottsdale Auction this January 26th. **We're pleased to waive our standard \$150 fee and offer Early Ford V-8 Club of America members free bidder registration** (use code "FORD22" at checkout) to take full advantage of this rare opportunity to acquire some great curated examples of the marque.

Highlights in the no-reserve Ron Thorne Collection include a very desirable 1932 Ford Deluxe Roadster that completed the Great American Race in 1985, being 1 of 6,893 produced, a two-time Dearborn Award-winning 1948 Mercury Convertible with less than 1,000 miles since its ground-up restoration, and a 1933 Ford Three-Window Coupe, another recipient of a frame-off restoration. Full details on the collection are available at www.WorldwideAuctioneers.com.

Bidding options are available to suit all comfort levels, including live, online, by phone, or absentee. Club members can take advantage of free bidder registration with code "FORD22" at checkout; register to bid by visiting www.WordwideAuctioneers.com or calling us at (260) 925-6789.

The Scottsdale Auction takes place on Wednesday, January 26th at 5 PM at Singh Meadows (1490 E Weber Dr, Tempe, AZ 85281). We look forward to seeing you soon!

John Kruse
Principal and Auctioneer

Rod Egan
Principal and Chief Auctioneer