



# Drive Lines

Chapter #40

MAR 22

*Our 51st Year*

*Visit Our Website*

*"ValleyV8s.org"*

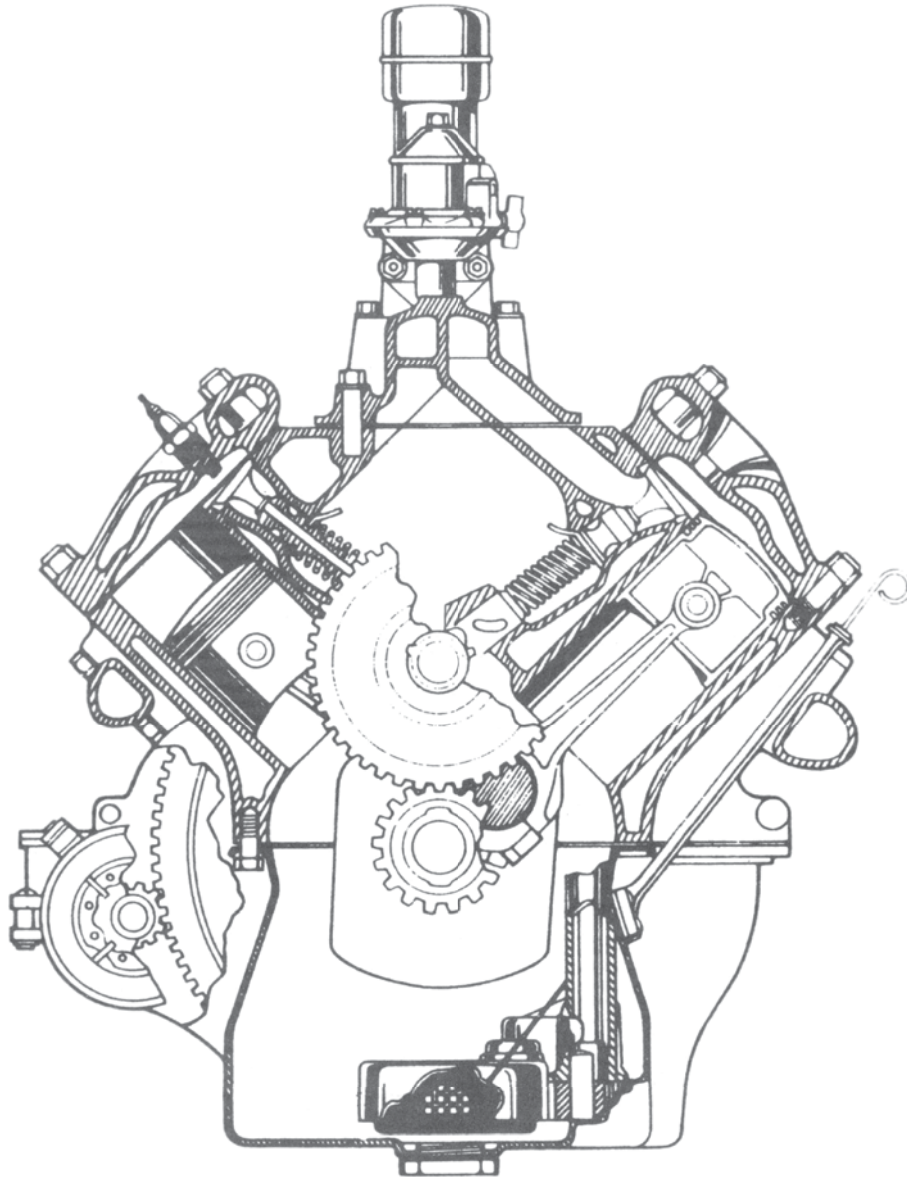

**The Valley V8's**  
**9700 Farralone, Chatsworth, Ca. 91311**

# The Valley V8's

2022

President	Ernie Baily	805-433-5540	<i>Past Presidents</i>	
Past Presidents	Vaskin Hagopian	323-661-2044	Jim Rowe	1971
Vice President	Jim Ellerbrock	818-437-0412	Doug Peterson	1972
Secretary	Rex Jaramillo	213-706-3854	Don Durkee	1973-1974
Treasurer	Joan Sapper	818-326-9685	Ed Warnock	1975
Tours	Ernie Baily	805-433-5540	John Busk	1976
Programs	Larry Caplan	818-363-2849	Chip Werstein	1977
	Joe DiFatta	818-700-1939	Stan Misraje	1978
Membership	Howard Brown	818-606-0267	Bill Culp	1979
	Joan Sapper	818-326-9685	Al Spencer	1980
Drive Lines	Robert Glucksman	818-618-1395	Larry Caplan	1981
Prize Raffle	Steve Lehman	818-885-6938	Bob Rose	1982
50/50	Ken Sapper	818-326-1286	Don Durkee	1983
Ladies / Birthdays / Sunshine	Bobby Searl	818-353-6767	Paul Kirk	1984
Name Badge	Karen Lehman	818-885-6938	Kent Lowry	1985
Car of the Month	Jim Ellerbrock	818-437-0412	Dave Sanborn	1986
Web Master	Scott Dudrick	818-687-9836	John Kemmerer	1987
			Dudley Ochsner	1988
			Jerry Jensen	1989-1990
			Joe DiFatta	1991
			Chuck Shubb	1992-1993
			George Richards	1994
			Jerry Littner	1995
			Dick Smith	1996
			Chuck Mair	1997
			Dennis Keene	1998
			Rose Golt	1999
			Don Stout	2000
			Steve Boskovich	2001-2002
			Joe DiFatta	2003
			Wendi Potter	2004
			Ken Sapper	2005-2006
			Steven Batesole	2007
			Harry Baker	2008-2009
			Dave Bergman	2010
			Randy Watson	2011-2012
			Steve Boskovich	2013-2014
			Stan Miller	2015
			Don Durkee	2015
			Vasken Hagopian	2016-2018
			Ernie Baily	2019-????

Meeting: 1st Tuesday of the Month, 6:00p

Visit our Web Site: [valley V8s.org](http://valleyV8s.org)

Facebook: **Valley V8s**

(<https://www.facebook.com/groups/579123315803014>)

Drive Lines is Published by

The San Fernando V8's Regional Group 40  
of the Early Ford V8 Club of America  
9700 Farralone, Chatsworth, Ca. 91311

**For more photos of Club Events,  
Please check out Web & Facebook sites**

Meeting at  
ROSIES  
8930 Corbin Ave,  
Northridge, CA 91324

**Our Next Meeting**  
**\*1 Mar 22\***

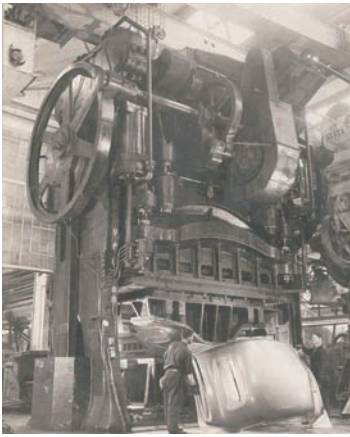

And now for some  
"Pressing" News

**What are you doing to stay Sane**  
**Write Me something**



**"Your Ad Here"**

For only \$5.00 a month,  
**YOU**  
can have your  
business card ad  
right here

For more details,  
Please call or Email Rob at  
818-882-2002, / madmodelr@aol.com  
Please put "Drivelines" in the subject  
Please make all payments to  
"Valley V8 Club"

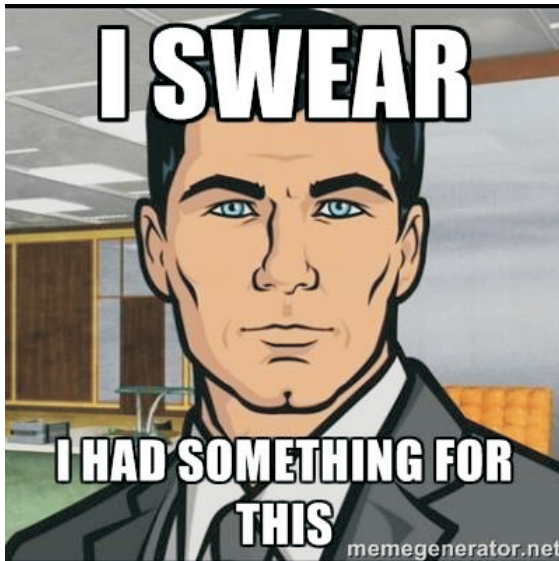

**HELLO FELLOW MEMBERS**

We would like to know more about You, Your Car...  
So, What I would like from our members is a picture of you  
with your car, with a small story. (1 Paragraph)  
That way, We get to learn more about our members, & we  
can put a face to a name & car

Please make all submissions to ether  
"Drivelines" at madmodelr@aol.com, or  
"Drivelines" 9700 Farralone Ave. Chatsworth, Ca. 91311

*Thank You*

Rob Glucksman, DL Editor

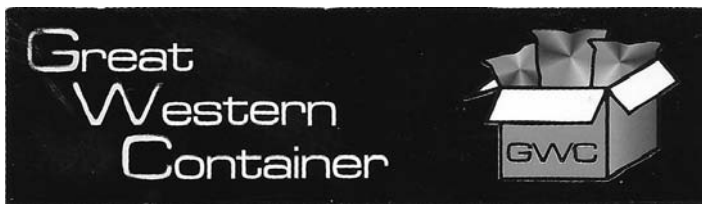

SOLUTIONS IN PACKAGING AND GRAPHIC DESIGN

**Steve Boskovich**

Office (818) 341-2291  
Cell (818) 903-6620  
Fax (818) 341-1050

P.O. Box 4074  
Chatsworth CA 91313



**AL MOONEY**  
C.F.O.

8744 REMMET AVE.  
CANOGA PARK, CA 91304  
(818) 998-0199  
FAX (818) 341-2073

al@mooneyindustries.com

**SPEEDWAY  
ENGINEERING**



**Ken Sapper**  
President

ken@1speedway.com  
Office: 818.362.5865  
Cell: 818.326.1286  
Fax: 818.362.5608  
13040 Bradley Avenue  
Sylmar, CA. 91342  
www.1speedway.com

MIKE QUIROGA  
President/CEO  
O: 818.780.8820  
F: 818.780.1713

16046 Blythe St.  
Van Nuys, CA 91406



ANNIVERSARY 1972-2012  
MIKE'S GOT YOU COVERED

www.mikesbuilding.com

# From The President

Hello Everyone,

We had a very good Feb. meeting! It was nice to see everybody after the holidays.

Well to start with, I would like to remind everyone our annual dues are due, please submit before our March 15th deadline to be included in the 2022 Roster.

I'll give you a progress report on my car projects. The first thing is that I'm still working on my Plymouths broken exhaust stud. I have attempted to do the removal my self and no luck, I have had two mobile mechanics help me and still no luck. I then went out and bought some new left handed drills and a new stud extractor kit along with some titanium drill bits, cobalt drill bits and still no luck. Then I had a conversation with Phil Goechi at our Thursday morning "Donut Run" at Earls Donuts and he has been kind enough to help me, and with his Machinist skills he made a drill guide and we are making some progress. I hope to have this fixed soon.

On the 56 Golden Hawk I repainted the stock wheels and detailed the whitewall tires so it looks real good. I'm just about ready to do the paint detail on the engine compartment of the 56 Packard 400. I'm also working on my brothers 64 GT Hawk, fixing the dash lights and the turn signal switch, plus fixing a ground on the gas tank sending unit. I haven't done anything other than start the 58 Studebaker President once and a while. Also my Dodge seems to working fine. Yea!

Howard and I are planning a joint tour with the the Studebaker club and our club to the Stagecoach Inn Museum in Newberry Park (Bring your collector cars). There is a \$ 7.00 admission/donation, \$5 ages 5 to 12, free for kids under 5. I'll get a flier out once we get it finalized. We are shooting for March 26th, Saturday. We will meet at Bobs Big Boy in Northridge at 9am-9:30am and depart at 10am. We'll do a non-freeway drive out to the Stagecoach Inn museum in Newberry Park arriving just prior to 11am which will allow us to have the limited parking just prior to general opening(11am) for our collector cars. I'm hoping to have only collector cars only in the front parking area. There is overflow parking at the park next to the Museum. I will do a sign up sheet at the meeting.

As always, please join us on Thursday mornings 8am at "Earl Donuts" in Chatsworth at Mason & Devonshire, and Friday evenings at 4pm at "Bobs Big Boy" in Northridge.

I know I have probably forgot something! But I'll see you at the meeting on March 1st.and hopefully I'll remember!

Prez Ernie

---

## From the Editor / Car of the Month



Well, it looks like I, your editor won the COTM, with My 55 Ford Mainline

I found this litl gem about 6 years ago in fellow members (Chuck Shubb) yard. Not much have I done to her, other than maintaining & I did do a front end.

She's bone stock, survivor, & she's in great shape.

I was looking for something I could mess with, But, she's in such

great shape , I dont have it in Me to mess with her, I RESPECT the metal

Thank you for your time

Rob / DLE /  
Ford Fairline



## Chapter 40 -- San Fernando Valley V-8's Club

### Monthly Meeting Minutes for Tuesday February 1, 2022

Meeting was opened at 7:00 pm by President Ernie Baily with the Pledge of Allegiance. He welcomed all. There were no visitors to introduce.

First item of business was a recap of the recent Officers' board meeting. The following was gone over:

**DRIVELINES-** Rob Glucksman has been working on shortening the mailing list. As of now there are only 15 members that prefer their edition sent in the mail. This has reduced our mailing costs. We thank each of you.

**TOURS** The following ideas for tours and trips were discussed, and various members will be working on. Ernie is open to any other suggestions: 1) Stagecoach Inn, Simi Valley Mid or end of March. 2) Overnight trip to Solvang. If interested let Ernie know. 3) Strathearn Historical Park & Museum, Simi Valley.

**HOLIDAY PARTY 2022** Jim Ellerbrock, VP, is looking ahead to December. Most members were happy using the Woodland Hills Country Club facilities and would like to go there again. Jim will meet with the Director and get our reservation in and get pricing. Again, this will be for a brunch. He will report on this at our next meeting. (Event is reserved for December 11<sup>th</sup>)

**NEW CLUB OFFICERS-2023** Please consider being an officer next year. Many of the present officers would like to pass on their duties. This would bring in new ideas and prevent burn-out from officers that have worked hard for numerous years. Just speak up if you are even a little interested. You would get plenty of help and encouragement.

**MEMBERSHIP** Howard Brown reminded us that our dues need to be received by March 30 to have your name in Roster. Our dues are \$35.00. Please call Howard if you are not sure you paid...or you can be sure he will call you! It is important that you ALSO are a member of The Early Ford V8 Club of America. Their dues are also \$35.00. Our local chapter is Regional Group 40, and we are under the National umbrella. The National Club has insurance to cover us in the event there be an accident during any of our club tours. Please find the membership application in this Drivelines and send it in.

**NATIONAL NEWS UPDATE:** Jerry Littner, our West Coast Director, explained the reasoning behind only awarding cars dating from 1932-1953 any of the prestigious classes. Our club's purpose states:  
*"Our club recognizes all Ford Motor Company vehicles made between 1932 and 1953, including Ford, Lincoln, Mercury, commercial vehicles, tractors and other Ford powered vehicles built around the world utilizing the 4, 6, 8, and 12 cylinder engines produced by Ford Motor Company."*

**NEW IDEAS:** A new club pin indicating number of years of membership or "Member since (year)." How about club shirts? A long sleeved and/or polo style. Steve Boskovich offered to research these and let us know at our March meeting.

**CLUB MEETING LOCATION:** Ernie is looking into moving our meeting location. Parking is most difficult here. If you have a new location in mind, please pass this onto Ernie.

**WEB PAGE:** Scott Doudrick thanks those who have submitted car photos for promoting our website. If you want to see your car in there, please send either an email or a hard copy along with any bragging information you would like to say about this car. All hard copy pictures will be returned to you.

**MOTION PICTURE CAR OPPTS:** Jim Ellerbrock has a contact that is occasionally needing older cars for TV or motion picture filming. If you would like to register your classic, let Jim know. Quite a few members have done this and had a fun time, made some side money, and were fed a great meal. Jim may get a future meeting program speaker regarding this.

**MINI-CAR SHOW IDEA** Joe DiFatta suggested meeting at a local senior living home in our classic Fords. The residents really enjoy seeing these beautiful cars. In times past, besides making new friends, they invited everyone to stay for lunch! Joe would be happy to make these arrangements if we are interested. Let him know!

#### **BREAK TIME:**

*Reports of Officers:*

Recording Secretary Rex Jaramillo had to miss tonight and has Joan Sapper filling in.

**Treasurer-**Joan Sapper reported "no report".

Birthdays and Anniversaries for February-Announced by Karen Lehman

**NASCAR REPORT-**Ken Sapper talked about this coming weekend's NASCAR Exhibition Race at the LA Coliseum. This event is the first "Busch Clash" race ever that was not held at Daytona Speedway. They claim between 50-70% of the ticket sales were to first-time race goers! NASCAR wants to appeal to a younger crowd. The asphalt ¼-mile track was built for this one-time use and will be removed right away. This event is a non-points race with a large purse to the winners. (BTW Joey Logano won in his Ford Mustang!)

**LOCAL CAR SHOWS:** Ernie brought numerous flyers covering future local events and cruises. Your best bet is to go online to [www.socalcarrculture.com](http://www.socalcarrculture.com) for the best source for events.

## Monthly Meeting Minutes Continued

**DRIVELINES REPORT** part 2: Rob added that the January edition was small due to the meeting being cancelled. He would love to add an article about you and your car. If he gets too much information, he says he can put it on the digital copies...that is, not the printed copies. See our Facebook page for that.

**PROGRAM** Our own Joe DiFatta gave us a brief background of his life. Thanks for sharing, Joe!

**AWARDS PRESENTED AND RAFFLES WON:**

**Ladies' Raffle** Bobbie Searl presented potted plants to winners Val Ellerbrock and Karen Lehman

**Name Badge** Karen Lehman presented the cash prize to President Ernie

**50/50 Cash Winner** Ken Sapper presented the big winner Harvey Jacobs \$40! (Not to mentioned Harvey picked his own ticket!)

**Car of the Month** Our fantastic Drivelines editor, Rob Glucksman and his cute 1955 Ford Mainline! Rob bought the car from member Chuck Schubbs 6 years ago. He "loves" the car. It's been maintenance free, the price of \$2000 was a steal. He just added a new front end. His neighbor, JoeDiFatta, can always hear him on his way down their neighborhood street. You deserved the award, Rob!

**RAFFLE #2** Steve Lehman's giant Raffle was great fun with many happy winners! Steve, we sure appreciate all your hard work to purchase and set-up our raffle table every month.

Meeting was ended at 8:30 pm by President Ernie See you all next month!

Minutes Submitted by Joan Sapper in Rex's absence

JS

---

### **Tails of the Garage, a Members Story**

The Evolution of my garage (and my car collection)

Over the years, as I have acquired more time (and a little more spendable cash) I have also acquired more collector cars. It started more than 60 years ago with a '49 Ford (I guess it wasn't really a collector car, it was just an old car a 16 year old could afford). Many cars followed, most of them at least somewhat interesting. Then along came marriage, kids and a house, and cars became transportation. As time went by, I decided that I needed (?) interesting cars, not just transportation. I kind of merged the two ideas when I bought my '69 GTO convertible (way back in 1972). It was our daily transportation (and our only vehicle until sometime in the middle 70's when America experienced our first 'gas crisis'). I bought a small, used car to commute to work and back and the GTO became a 'collector/fun' car. We didn't have a vehicle storage issue at that time because we only had one collector car and one 'transportation' car. That didn't last long as I continued to look at and eventually buy more collector cars.

Now, on to the garage portion of this; about 15 years ago, I took a look at what I had and where I could park them and realized I had a problem. After some serious marital discussions, we decided that I could absorb our side yard for 'car stuff' and we'd still have a nice backyard. This evolved from an extension to our driveway for access to the 'new' area, to a 20 x 20 concrete slab behind a pair of 10 foot wide by 6 foot high gates. Hooray! I could now park 2 cars behind the gate and 2 more on the new driveway in front of the gate. As time went by, my collection grew from the '69 GTO (which I still have FIFTY YEARS LATER!) to include (one at a time additions) a '49 Chevy Fleetline 4 door, a '53 Studebaker Commander Starliner, a '56 Studebaker Golden Hawk, a '55 Ford Fairlane Crown Victoria and a '62 Studebaker Gran Turismo Hawk. Where to put all these cars (and to maintain them)? Over a period of a couple years, the 20 x 20 slab became 20 x 50, a 6 foot high vinyl fence surrounded the area, a roof was erected over the rear 30 feet of the area and just recently the roof was extended forward, so that now the entire area is covered. In the last 5 or 6 months, I have run electrical conduit along both sides of the structure (to provide convenient plugs for working with electrical tools as well battery maintainers adjacent to each car) and LED lights strategically placed to illuminate the entire area.

I am writing this article, because I suspect (and in some cases I know) that many of our club members have gone thru similar 'vehicular evolution', and I thought it would be interesting to showcase some of our members' cars/garages. I hope this is somewhat interesting and encourages some of you to write something similar for our newsletter, or invite me to tour YOUR garage and I'll write the articles and take the pictures.

"Pics are posted on our websites"

Howard Brown

**The Valley V-8's  
2022 Membership Application & Renewal Form**

**In order to continue to receive the Drivelines and remain in the roster**

**Or to join our club**

**Please renew your membership by February 15, 2022**

**Name:** \_\_\_\_\_ **Birthday Month:** \_\_\_\_\_ **Day:** \_\_\_\_\_

**Spouse:** \_\_\_\_\_ **Birthday Month:** \_\_\_\_\_ **Day:** \_\_\_\_\_

**Address:** \_\_\_\_\_ **City:** \_\_\_\_\_ **State & Zip** \_\_\_\_\_

**Phones - Home** \_\_\_\_\_ **Cell** \_\_\_\_\_ **Work** \_\_\_\_\_

**Email:** \_\_\_\_\_

**Occupation:** \_\_\_\_\_

**Year Joined:** \_\_\_\_\_

**Early Ford V-8 Vehicle(s) Owned - if same as prior year write "NO CHANGE"**

<u>Year</u>	<u>Make</u>	<u>Model</u>	<u>Body</u>	<u>Style</u>

**For Regional Membership: Send a \$35.00 check - payable to: Valley V-8's**

**Mail check to: Valley V8's C/O Howard Brown, 20036 Tuba St. Chatsworth, Ca.  
91311**



**If you have any questions please call 818-606-0267 Email: brngarage@gmail.com**

**NOTE: For us to meet insurance requirements, a Regional Group Member MUST also be a member of the Early Ford V-8 Club of America. Minimum membership is \$35.00 per year. Please contact me for mailing information or <http://www.earlyfordv8.org>**



# You're invited to Join

Mail In Membership Application Form

	<h2>Early Ford V-8 Club of America</h2> <p><i>An International Organization</i></p>	
<b>MEMBERSHIP APPLICATION</b>		
<input type="checkbox"/> New Membership <i>Check Box as Required</i> <input type="checkbox"/> Renewal Membership		
MEMBER NAME _____		Regional Group: _____
JOINT NAME _____		
ADDRESS _____		
CITY _____	STATE _____	ZIP _____
TELEPHONE _____	COUNTRY _____	
<u>CAR(S) OWNED</u>		
<u>YEAR</u> <i>Sample: 1940</i>	<u>MAKE</u> <i>FORD</i>	<u>TRIM</u> <i>DELUXE</i>
	<u>ENGINE</u> <i>V-8</i>	<u>BODY STYLE</u> <i>TUDOR SEDAN</i>
_____		
_____		
_____		
<p>PLEASE SEND FORM &amp; PAYMENT TO:  <b>THE EARLY FORD V-8 CLUB OF AMERICA</b>          c/o Cornerstone Registration, Ltd.          P.O. Box 1715      Toll Free (866) 427-7583 (in USA)          Maple Grove, MN 55311      (763) 420-7829 / FAX (763) 420-7849          Email: <a href="mailto:registration@cornerstonereg.com">registration@cornerstonereg.com</a></p>		
<p><b>Credit Card:</b>    VISA    MASTERCARD (circle one)          CARD # _____          EXPIRATION DATE: _____          SIGNATURE: _____</p>		
<b>ALL FUNDS ARE US \$</b>		
<p><u>United States</u>  <input type="checkbox"/> Annual-Surface Mail          Regular Membership \$35, Joint Membership \$38  <input type="checkbox"/> Three Year-Surface Mail          Regular Membership \$100, Joint Membership \$109</p>		
<p><u>Mexico, South America, Europe &amp; Pacific Rim</u>  <input type="checkbox"/> Annual-Surface Mail          Regular Membership \$70, Joint Membership \$75  <input type="checkbox"/> Three Year-Surface Mail          Regular Membership \$200, Joint Membership \$210</p>		
<p><u>Canada</u>  <input type="checkbox"/> Annual-Surface Mail          Regular Membership \$55, Joint Membership \$58  <input type="checkbox"/> Three Year-Surface Mail          Regular Membership \$150, Joint Membership \$160</p>		
<p><b>NEW: Digital Format for Both Magazine and Annual Roster</b>          (digital version emailed to you, no magazine or roster mailed)  <input type="checkbox"/> <b>Annual Digital Membership</b>          Regular Digital Membership \$30          Your Email Address: _____</p>		
<p><u>Membership without V8 TIMES Delivery</u>      One-Year      Three-Year</p> <p><input type="checkbox"/> U.S. &amp; All Foreign Countries:      Regular \$15    Joint \$18      Regular \$45    Joint \$54 <i>WITH</i> Membership Roster only.</p> <p><input type="checkbox"/> U.S. &amp; All Foreign Countries:      Regular \$ 5    Joint \$ 5      Regular \$15    Joint \$15 <i>WITHOUT</i> Membership Roster.</p>		
<p><b>Thank you for Joining or Renewing your membership in The Early Ford V-8 Club of America</b></p> <p>How did you find out about us? _____</p>		

### Early Ford V-8 Club of America

*An International Organization*

Established in 1963 We are dedicated to the restoration and preservation of all Ford Motor Company vehicles, 1932 through 1953.