



# Drive Lines

Chapter #40

Apr 22

*Our 51st Year*

*Visit Our Website*

*"ValleyV8s.org"*

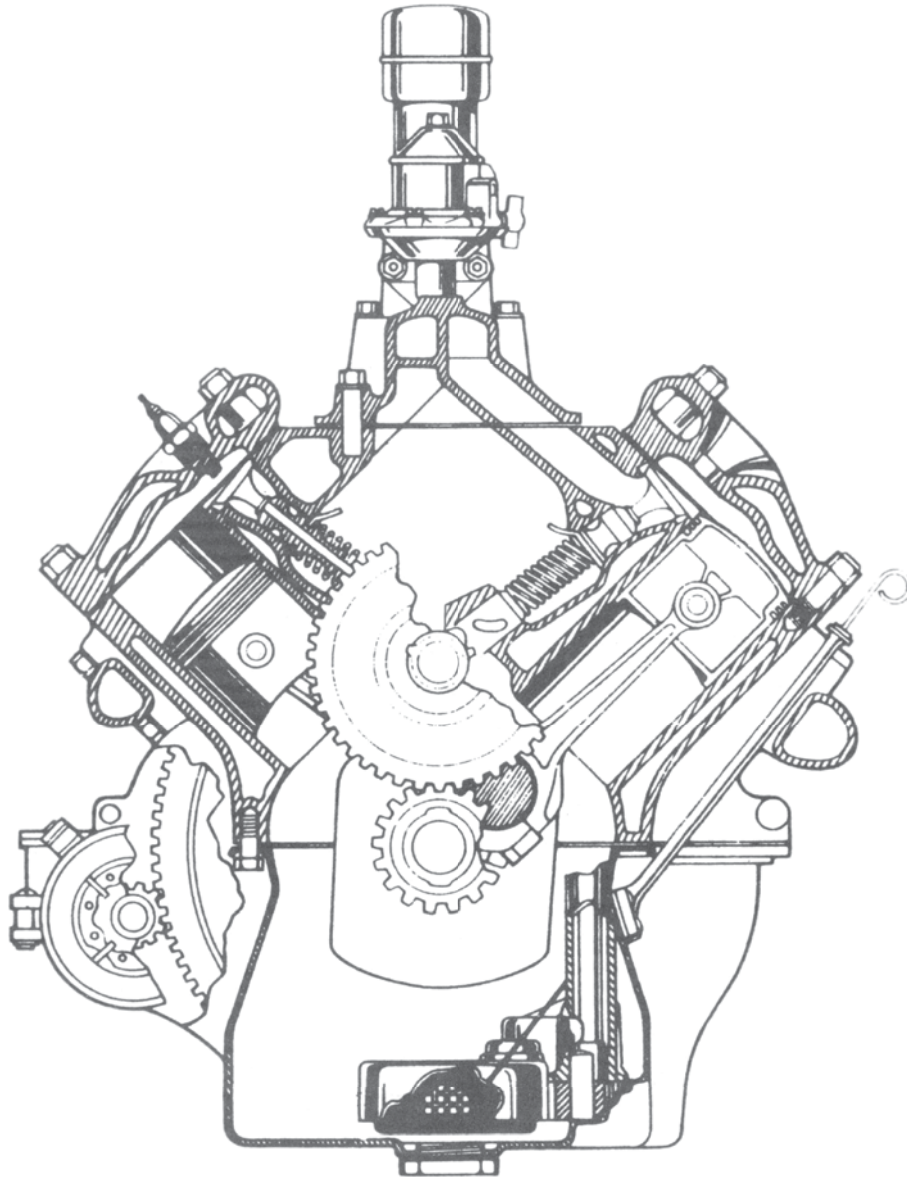

**The Valley V8's**  
**9700 Farralone, Chatsworth, Ca. 91311**

# The Valley V's

2022

President	Ernie Baily	805-433-5540
Past Presidents	Vaskin Hagopian	323-661-2044
Vice President	Jim Ellerbrock	818-437-0412
Secretary	Rex Jaramillo	213-706-3854
Treasurer	Joan Sapper	818-326-9685
Tours	Ernie Baily	805-433-5540
Programs	Larry Caplan	818-363-2849
	Joe DiFatta	818-700-1939
Membership	Howard Brown	818-606-0267
	Joan Sapper	818-326-9685
Drive Lines	Robert Glucksman	818-618-1395
Prize Raffle	Steve Lehman	818-885-6938
50/50	Ken Sapper	818-326-1286
Ladies / Birthdays / Sunshine	Bobby Searl	818-353-6767
Name Badge	Karen Lehman	818-885-6938
Car of the Month	Jim Ellerbrock	818-437-0412
Web Master	Scott Dudrick	818-687-9836

Meeting: 1st Tuesday of the Month, 6:00p

Visit our Web Site: [valley V8s.org](http://valley V8s.org)

Facebook: **Valley V8s**

(<https://www.facebook.com/groups/579123315803014>)

Drive Lines is Published by

The San Fernando V8's Regional Group 40

of the Early Ford V8 Club of America

9700 Farralone, Chatsworth, Ca. 91311

**For more photos of Club Events,  
Please check out Web & Facebook sites**

## Change of Venue

For the month of 5 APR 22, We will be trying  
Mimi's Cafe for our April meeting

**Mimi's Cafe**  
**19710 Nordoff Pl.**  
**Chatsworth, Ca. 91311**

### *Past Presidents*

Jim Rowe	1971
Doug Peterson	1972
Don Durkee	1973-1974
Ed Warnock	1975
John Busk	1976
Chip Werstein	1977
Stan Misraje	1978
Bill Culp	1979
Al Spencer	1980
Larry Caplan	1981
Bob Rose	1982
Don Durkee	1983
Paul Kirk	1984
Kent Lowry	1985
Dave Sanborn	1986
John Kemmerer	1987
Dudley Ochsner	1988
Jerry Jensen	1989-1990
Joe DiFatta	1991
Chuck Shubb	1992-1993
George Richards	1994
Jerry Littner	1995
Dick Smith	1996
Chuck Mair	1997
Dennis Keene	1998
Rose Golt	1999
Don Stout	2000
Steve Boskovich	2001-2002
Joe DiFatta	2003
Wendi Potter	2004
Ken Sapper	2005-2006
Steven Batesole	2007
Harry Baker	2008-2009
Dave Bergman	2010
Randy Watson	2011-2012
Steve Boskovich	2013-2014
Stan Miller	2015
Don Durkee	2015
Vasken Hagopian	2016-2018
Ernie Baily	2019-????

**Our Next Meeting**  
**\*5 Apr 22\***

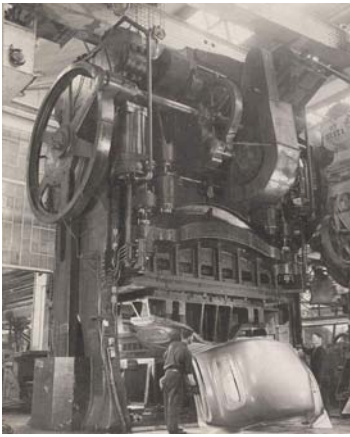

And now for some  
"Pressing" News

**What are you doing to stay Sane**  
**Write Me something**

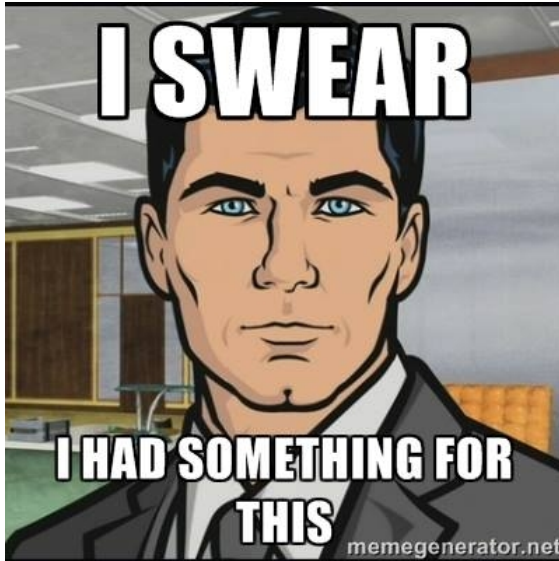
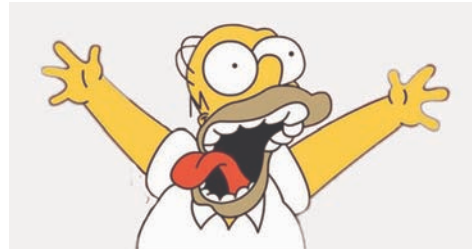

**"Your Ad Here"**  
For only \$5.00 a month,  
**YOU**  
can have your  
business card ad  
right here

For more details,  
Please call or Email Rob at  
818-882-2002, / madmodelr@aol.com  
Please put "Drivelines" in the subject  
Please make all payments to  
"Valley V8 Club"

## HELLO FELLOW MEMBERS

We would like to know more about You, Your Car...  
So, What I would like from our members is a picture of you  
with your car, with a small story. (1 Paragraph)  
That way, We get to learn more about our members, & we  
can put a face to a name & car

Please make all submissions to ether  
"Drivelines" at madmodelr@aol.com, or  
"Drivelines" 9700 Farralone Ave. Chatsworth, Ca. 91311

Thank You

Rob Glucksman, DL Editor



SOLUTIONS IN PACKAGING AND GRAPHIC DESIGN

**Steve Boskovich**

Office (818) 341-2291  
Cell (818) 903-6620  
Fax (818) 341-1050

P.O. Box 4074  
Chatsworth CA 91313



**AL MOONEY**  
C.F.O.

8744 REMMET AVE.  
CANOGA PARK, CA 91304  
(818) 998-0199  
FAX (818) 341-2073

al@mooneyindustries.com

**SPEEDWAY**  
**ENGINEERING**



**Ken Sapper**  
President

ken@1speedway.com  
Office: 818.362.5865  
Cell: 818.326.1286  
Fax: 818.362.5608  
13040 Bradley Avenue  
Sylmar, CA. 91342  
www.1speedway.com

MIKE QUIROGA  
President/CEO  
O: 818.780.8820  
F: 818.780.1713

16046 Blythe St.  
Van Nuys, CA 91406



ANNIVERSARY 1972-2012

MIKE'S GOT YOU COVERED

www.mikesbuilding.com

# From The President

Hello Everyone,

To start with some sad news our friend Don Stout has just passed. {I don't have any details at this time but as soon as we know any information we will pass it on.

Both Jim and I are going to scout a couple locations to consider moving our meeting location. I would like to find a location that has good food & service and good parking for out vintage cars.}

(this was current at time of writing, however is now outdated....Rob/DLE)

As far as my car reports go I have just finished repairing the broken exhaust stud on my 48 Plymouth. Many thanks to Phil Goeschl as a retired machinist he made it look easy. After three visits he had the new stud in and ready to reassemble. Also I'm about mid way through my Painting/detailing of the engine compartment of my brothers 56 Packard 400, which I hope to have complete soon.

As far as Car events go we still go to "Earls Donuts" on Thursday morning (otherwise known as "Steves Donut Run"! I try to go to "Bobs Big Boy" on Friday nights. Also here are a few upcoming Cars Shows that look like they might be good.

# March 26th Studebaker Club/ Valley V8 Club Tour to the "Stagecoach Inn Museum"

# April 2nd The Coachmens Cruise night at the Rock N Roll Cafe in Simi Valley, Ca (April-November) 1st Sat of Month

# April 16th -Classic Studebaker Car Show Bobs Big Boy, Northridge 8am-12noon # April 23 & 24 Spring Fling 34 Mopar Car Show at Woodley Park, Van Nuys

# April 24 Fabulous Fords Forever Car Show at Irwindale Speedway 10am-3pm

# May 1st Classic Chevys Car Show at Rancho San Antonio , Chatsworth # May 28th Ridge Route Run & Car Show Frazier Park, Ca

# June 12th Road Kings Car Show at Bob Hope Park in Burbank

# July 16th Glendale Cruise Night car show

Check on [Socalcarculture.com](http://Socalcarculture.com) for many more car shows and details.

I hope to see you on our up coming Studebaker Club/Valley V8 Club Tour on March 26.

I'm sure I forgot something ! However I hope to see you at the next Club meeting April 5th,

Prez Ernie

---

## Car of the Month

Steve Boskovich and his fine '57 Ford walked away with honors this month. Did you see that beauty? Man, showroom City! And Steve had a '57 when he was 19. He recently located this gorgeous gem in Las Vegas. It was treated to a no-cost-spared restoration, had a perfect interior, paint with slight overspray just like factory. Then it was placed into storage for nine years, awaiting a good-guy to buy, and along came Steve. The deal was closed, and Steve scored: The car even came with a complete factory supercharger kit! Now Steve could have had the fastest '57 Ford in Chatsworth, heck, probably in the whole valley, but alas, would have meant too many changes and modifications to his righteous '57. So he has the supercharger setup for sale. Congratulations, Steve, nice '57!



**Chapter 40 -- San Fernando Valley V-8's Club**  
**Monthly Meeting Minutes for**  
**Tuesday March 1, 2022**

**6:55 pm: Meeting called to order.** President Ernie Baily launched the meeting with the pledge of allegiance.

**Joe Defatta:** Led us in a moment of silence to honor our dear friend, Don Stout.

**Ernie Baily:** Honored our guests for the evening, Laurel and Roger Rosenberg.

Mentioned a reminder to join the Early Ford V-8 Club of America National, which provides insurance for us during some club activities. For more specific information about this, visit the Early Ford V-8 Club of America website. It also entitles members to receive the swell V-8 Times magazine. Secondly, a reminder to pay the dues for our local Club -- San Fernando Valley V-8's.

**Steve Boskovich:** Announced that Phil Hall had a recent heart attack. Thankfully he survived and is feeling better.

**Ernie Baily:** Update on car-fix activities Broken studs on his engine: Two 'mole' mechanics had tried before but were not successful in removing the studs. Phil Gorsch to the rescue: He went to Ernie's pad and, success, the broken studs are now removed! Ernie also mentioned doing some work on other Baily family collectibles: a '64 Studebaker Hawk GT and a '56 Packard. 'A little at a time.'

**Blake Wilcox:** Sandy Norris's well-known '49 Ford Tudor semi-custom 'Lil' Darlin', had clutch failure. So Blake rolled up his sleeves and jumped right in. He discovered that Sandy's swell shoebox was equipped with some high-performance drivetrain pieces: a light-weight aluminum flywheel and a heavy-duty Merc clutch. However there were different sized splines, etc. going on. It took some research and discovery work on Blake's part to match everything up. But success, new clutch is in, and Sandy can get second-gear scratch again. Well done, Blake!

**Ken Sapper:** Talked about NASCAR, Daytona Beach where Fords won big time. However the big 'local' NASCAR news was the 'Busch Clash' Coliseum race held last month at the L.A. Coliseum. A record-setting 54,000 people showed up for the main event, a 300-lap race. And the next week was a NASCAR event in Las Vegas.

**7:15 pm:** Break called

**7:30 pm:** Meeting resumed

**Report from Officer's:** All A-OK.

**Rob Glucksman:** Rob talked about his son's late-model car catalytic converter theft.

**Membership:** Dues are still trickling in. Badges are being offered to new members.

**Car of the Month:** Steve Boskovich and his fine '57 Ford walked away with honors this month.

**Ladies Raffle:** Handled by Bobby 'green-thumb' Searl. The first beautiful flower arrangement was won by new member Laurel Rosenberg. The second flower arrangement was won by Helen Baker.

## Monthly Meeting Minutes Continued

**Ernie Bailly:** Upcoming events. 1) March 20 -- Glendale Elks Car Show. 2) March 26 -- Studebaker Club Tour to the Stage Coach Museum in Newberry Park. This most excellent event is being arranged by Howard Brown and Ernie Bailly. There's no freeway driving, excellent parking available, and lunch afterwards, TBD. 3) April 24 -- Fabulous Fords Car Show, Irwindale Speedway. 4). May 28 -- The Ridge Route Car Show. This is a fun Tour on a road cleared by private parties.

**Name Badge drawing:** Won by a prosperous Kieran 'Cash' Doudrick.

**Speaker for the evening:** Larry Caplan introduced our own Ralph Hubbard, who is the expert of experts on early Ford V-8's and what they're worth.

**50/50 raffle:** Won by Rex 'Luckout' Jaramillo.

**Prize raffle:** Handled this month by Steve Boskovich.

**8:30 pm:** Meeting adjourned.

Minutes submitted by Club secretary Rex Jaramillo.

---

## From the Secretary & Editor

**Rob Glucksman:** Rob talked about his son's late-model car catalytic converter theft. Reseda Muffler to the rescue: They replaced the catalytic converter and welded in some anti-theft cables. This will help prevent a recurring theft. Reseda Muffler also offers anti-theft kits for other cars. Thanks for the tip, Rob.

Actually, This was the 2nd time this happened to My Sons car...

Only this time, they cut the converter, but couldnt cut the safty cable that the muffler shop added, + the crook got caught. So.. back to Reseda Muffler for welding the unit, & 1 more cable added that is visable. (Rob / DLE)

**(Secretary's Note:** Catalytic converters help clean up the exhaust gases leaving the engine. They also muffle exhaust sound. If you hear a vehicle that looks otherwise stock but has a loud exhaust note, it may be the result of catalytic converter theft, which is on the increase. Precious metals used in the converters make them valuable on the black market: \$200-plus each.)

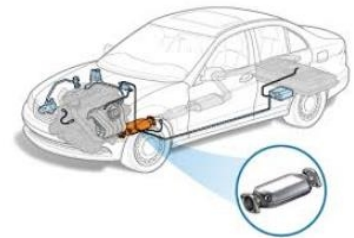

# Upcoming Tour

Hi Everyone:

Attached is information about Our Driving Tour our Club is doing with the local region of the Studebaker Club on ***Saturday March 26th***. Please check out the info and let me know if you will be joining the tour, so when we meet for the start we can be sure nobody gets left behind. If you have any questions about the tour, please contact Prez Ernie so He can get answers for you. Hopefully we'll have a good turnout and a great time.

Valley V8 Club / Studebaker club

Non-Freeway Joint tour

March 26, 2022

Destination: Stagecoach Inn Museum

51 S. Ventu Park Road

Newbury Park, California

Admission: \$7 adult, \$5 5yrs-12,

Free for kids under 5

Open 1pm to 4pm, Saturdays and Wednesdays

805-498-9441

[www.StagecoachInnMuseum.com](http://www.StagecoachInnMuseum.com)

Meeting Place: Bobs Big Boy Restaurant

8876 Corbin Ave, Northridge, CA 91324

Meeting time: 10am-10:30am

Depart Time: 11am

Arrival at Museum: Arrive at 12noon for preferred parking prior to regular opening time  
(only Vintage Cars if possible in the front parking)

Route: North on Corbin to Devonshire, turn left on Devonshire, West on Devonshire to Topanga Blvd.

Turn right and head north to the Santa Susana Pass Rd.

Turn left on Santa Susana Pass Rd. and head over to Simi Valley. Santa Susana Pass Rd. turns into Kuehner Ave. Stay on Kuehner Dr. to Los Angeles Ave. Turn Left on Los Angeles Ave. heading west to Tapo Cyn Road turn Left, go to Royal Ave turn right, proceed on Royal Ave to Madera Rd. turn left on Madera Rd.

Continue onto E Olson Rd. 3.9miles

Continue onto Lynn Rd. 2.9miles

Continue straight to stay on Lynn Rd. 1.5miles

Turn right onto Susan Dr. Destination will be on the right

51 S. Ventu Park Rd.

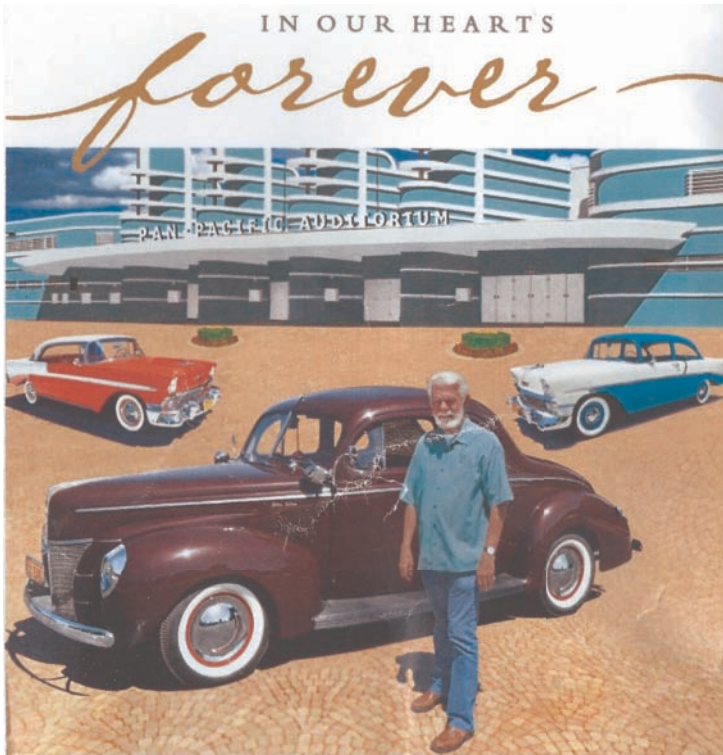

*DON ALLEN STOUT*

JUNE 6, 1939 - MARCH 13, 2022  
HEADED TO HOT ROD HEAVEN...

*A Loving & Caring Grandfather,  
Father, Husband, Uncle, Cousin and  
Friend to so many.*

LIFE'S LIKE A ROAD THAT YOU TRAVEL ON.  
WHEN THERE'S ONE DAY HERE AND THE NEXT DAY  
GONE.  
SOMETIMES YOU BEND, SOMETIMES YOU STAND.  
SOMETIMES YOU TURN YOUR RACK TO THE WIND.  
THERE'S A WORLD OUTSIDE EV'RY DARKENED DOOR...  
WHERE BLUES WON'T HAUNT YOU ANYMORE.  
WHERE BRAVE ARE FREE AND LOVERS SOAR...  
COME RIDE WITH ME TO THE DISTANT SHORE.  
WE WON'T HESITATE...  
TO BREAK DOWN THE GARDEN GATE.  
THERE'S NOT MUCH TIME LEFT TODAY.  
LIFE IS A HIGHWAY:  
I WANNA RIDE IT ALL NIGHT LONG.  
IF YOU'RE GOING MY WAY...  
I WANNA DRIVE IT ALL NIGHT LONG.

*Please check Our web site for more pic's of Don's KOOL Stuff*



HEADED TO HOT ROD HEAVEN...

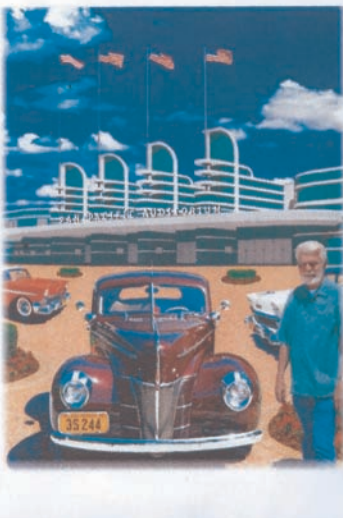



### ***Speaker for the evening:***

Larry Caplan introduced our own Ralph Hubbard, who is the expert of experts on early Ford V-8's and what they're worth. Ralph has quite the background in our hobby. He bought his first FoMoCo car in 1955, a '39 Merc convertible with a rebuilt engine and new brakes, only paid \$85, and could pull 65 mph-plus in second gear. Ralph was hooked. In 1968 he joined the Early Ford V-8 Club of America. Over the years he's held many leadership positions including Chief Judge at several National Meets. He was even National President in 1981! So this guy's got credentials and experience in early Fords like few others.

For our program Ralph discussed early Ford dollar values a subject that we're always interested in. The basis of his up-to-date information was a recent auction in Arizona that Ralph attended for cars from the Ron Thorne early Ford V-8 car collection. Ralph highlighted and discussed the value of many Ford V-8's from that collection. Here are five examples: 1) '32 Ford roadster, nicely restored, participated in the Great American Race in 1985: Sold for \$85,000. 2) '33 Ford Cabriolet convertible, mostly stock-look with beefier tires, dropped front axle and a hopped flathead: Sold for \$65,000. 3) 1932 Ford 3-window Coupe. Only two owners since 1948. Not perfect, #3 condition, but has provenance. Sold for \$50,000. 4) 1933 Ford 3-window coupe. Nice, equipped with a radio, good fit and finish, #2 condition. Sold for \$67,500. 5) 1934 Ford 3-window Coupe. #2 condition, equipped with a radio. Sold for \$49,500. It's not cheap buying a car at an auction. The above prices did not include the 12% fee charged by the Auction company 'World Wide Auctioneers' and the 8% Arizona state tax. So the final out-the-door prices for the above examples were 20% more than the prices shown above. Poorhouse here we come!

Ralph kept us spellbound as he presented the above very pertinent information to our group with a slideshow backdrop. Because of the restaurant modified hours/earlier closing time, Ralph wasn't able to finish his presentation. So he'll be back to another Club meeting soon to summarize and bring us more information about early Ford V-8 pricing. Thanks, Ralph, it's always fascinating and worthwhile to hear your most excellent information about our cars and their values. Looking forward to next time.



# Change of Venue

For the month of 5 APR 22, We will be trying Mimi's Cafe for our April meeting

**MIMI'S CAFE**  
**19710 Nordhoff Pl.**  
**Chatsworth, Ca. 91311**

