



Drive Lines

Chapter #40

Aug 22

Our 51st Year

Visit Our Website

"ValleyV8s.org"

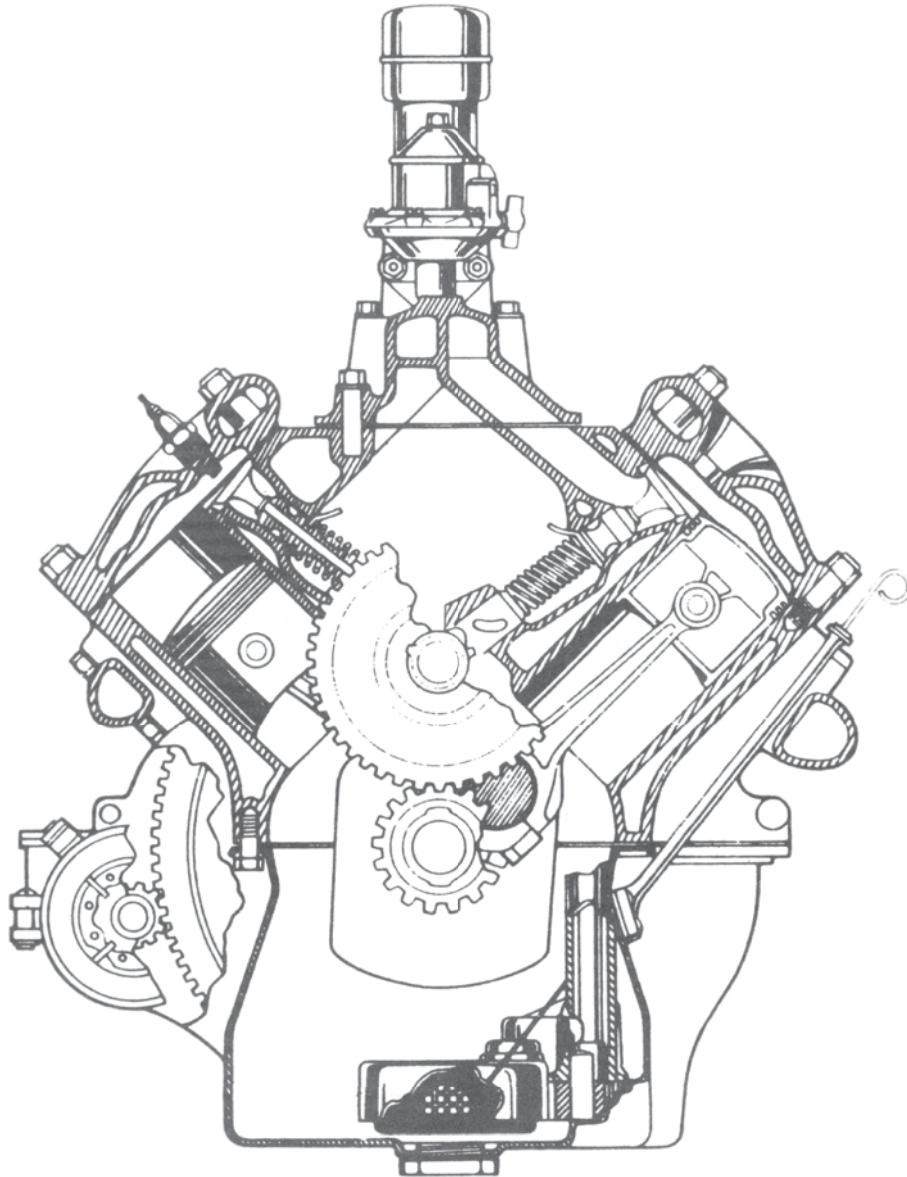

The Valley V8's
9700 Farralone, Chatsworth, Ca. 91311

The Valley V's

2022

President	Ernie Baily	805-433-5540
Past Presidents	Vaskin Hagopian	323-661-2044
Vice President	Jim Ellerbrock	818-437-0412
Secretary	Rex Jaramillo	213-706-3854
Treasurer	Joan Sapper	818-326-9685
Tours	Ernie Baily	805-433-5540
Programs	Larry Caplan	818-363-2849
	Joe DiFatta	818-700-1939
Membership	Howard Brown	818-606-0267
	Joan Sapper	818-326-9685
Drive Lines	Robert Glucksman	818-618-1395
Prize Raffle	Steve Lehman	818-885-6938
50/50	Ken Sapper	818-326-1286
Ladies / Birthdays / Sunshine	Bobby Searl	818-353-6767
Name Badge	Karen Lehman	818-885-6938
Car of the Month	Jim Ellerbrock	818-437-0412
Web Master	Scott Dudrick	818-687-9836

Meeting: 1st Tuesday of the Month, 6:00p

Visit our Web Site: [valley V8s.org](http://valleyV8s.org)

Facebook: **Valley V8s**

(<https://www.facebook.com/groups/579123315803014>)

Drive Lines is Published by

The San Fernando V8's Regional Group 40

of the Early Ford V8 Club of America

9700 Farralone, Chatsworth, Ca. 91311

**For more photos of Club Events,
Please check out Web & Facebook sites**

**Looks like we on the
move again**

Past Presidents

Jim Rowe	1971
Doug Peterson	1972
Don Durkee	1973-1974
Ed Warnock	1975
John Busk	1976
Chip Werstein	1977
Stan Misraje	1978
Bill Culp	1979
Al Spencer	1980
Larry Caplan	1981
Bob Rose	1982
Don Durkee	1983
Paul Kirk	1984
Kent Lowry	1985
Dave Sanborn	1986
John Kemmerer	1987
Dudley Ochsner	1988
Jerry Jensen	1989-1990
Joe DiFatta	1991
Chuck Shubb	1992-1993
George Richards	1994
Jerry Littner	1995
Dick Smith	1996
Chuck Mair	1997
Dennis Keene	1998
Rose Golt	1999
Don Stout	2000
Steve Boskovich	2001-2002
Joe DiFatta	2003
Wendi Potter	2004
Ken Sapper	2005-2006
Steven Batesole	2007
Harry Baker	2008-2009
Dave Bergman	2010
Randy Watson	2011-2012
Steve Boskovich	2013-2014
Stan Miller	2015
Don Durkee	2015
Vasken Hagopian	2016-2018
Ernie Baily	2019-????

**Lulu's Restaurant
& Sports Bar
16900 Roscoe Blvd,
Van Nuys, CA 91406**

**Our Next Meeting
*9 Aug 22***

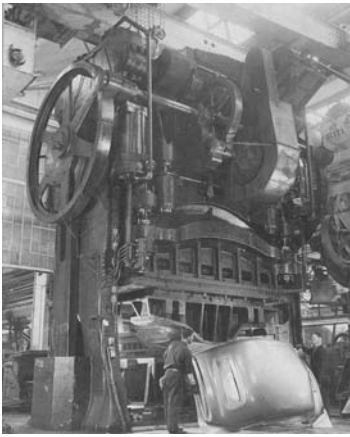

And now for some
"Pressing" News

What are you doing to stay Sane
Write Me something



"Your Ad Here"
For only \$5.00 a month,
YOU
can have your
business card ad
right here

For more details,
Please call or Email Rob at
818-882-2002, / madmodelr@aol.com
Please put "Drivelines" in the subject
Please make all payments to
"Valley V8 Club"



HELLO FELLOW MEMBERS

We would like to know more about You, Your Car...
So, What I would like from our members is a picture of you
with your car, with a small story. (1 Paragraph)
That way, We get to learn more about our members, & we
can put a face to a name & car

Please make all submissions to ether
"Drivelines" at madmodelr@aol.com, or
"Drivelines" 9700 Farralone Ave. Chatsworth, Ca. 91311

Thank You
Rob Glucksman, DL Editor

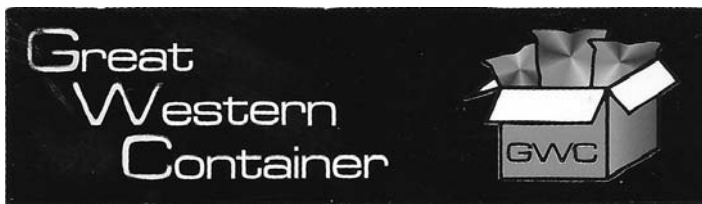

SOLUTIONS IN PACKAGING AND GRAPHIC DESIGN

Steve Boskovich

Office (818) 341-2291
Cell (818) 903-6620
Fax (818) 341-1050

P.O. Box 4074
Chatsworth CA 91313



8744 REMMET AVE.
CANOGA PARK, CA 91304
(818) 998-0199
FAX (818) 341-2073

AL MOONEY
C.F.O.

al@mooneyindustries.com

**SPEEDWAY
ENGINEERING**



Ken Sapper
President
ken@1speedway.com
Office: 818.362.5865
Cell: 818.326.1286
Fax: 818.362.5608
13040 Bradley Avenue
Sylmar, CA. 91342
www.1speedway.com

MIKE QUIROGA
President/CEO
O: 818.780.8820
F: 818.780.1713

16046 Blythe St.
Van Nuys, CA 91406

MIKE'Sth
ROOFING & BUILDING

ANNIVERSARY 1972-2012

MIKE'S GOT YOU COVERED

www.mikesbuilding.com

From The President

Hello Everyone,

First, I would like to thank all that attended our July 9th tour to the Valley Relics Museum, although it was "Hot" it seems that all enjoyed the tour. After a number of us went over to LuLu's Restaurant close by and had lunch in their meeting room. It was large enough to seat approx. 65 People. We decided that we would have the Aug meeting there. We were not able to book the first Tuesday so we booked the 2nd Tuesday, Aug 9th. unfortunately Mimi's Restaurant moved us back to the smaller back room, which they rearranged the room to seat 35 the most that would fit and it was very tight. The arrangement made it very crowded, and did not allow for additional people very well, so we went back to the list of other locations that would work for us and the next one was LuLu's Restaurant 16900 Roscoe Blvd. (Balboa & Roscoe)

Our next tour is the "Old Fashioned Day in the Park" in Marina Del Rey. So send in your entry form right away so they know how many are coming from our club. We will meet you all there the morning of July 24th.

The August tour is going to be a "Driving "tour to the "Wings over Camarillo" Air Show & Car Show on Sunday Aug. 21st. I'm still looking for a starting point to do the driving tour there.

Also you may already know, Steve Boskovich is planning to do his BBQ event on Aug. 27th. I'm sure he will have flyers and a signup list at the meeting. It should be a lots of Fun! Now, not much to report on my old car projects, but I did get the new radiator installed and fixed some minor wiring issues, and the 56 Golden Hawk seems to working OK. As far as the other cars goes, Rob is helping me with the Packard valve covers and I did take some time to run the 58 Studebaker President the other day. My Plymouth is working great now that the head gasket is repaired and I still need to address the A/C on my 55 Dodge.

Well, Thats about all for now, I'll see you at our next meeting Tuesday Aug. 9th.

Prez Ernie

Chapter 40 San Fernando Valley V-8's Monthly Meeting for Tuesday, July 5, 2022

7:00 pm Meeting called to order by President Ernie Baily and led the Pledge of Allegiance.

Ernie is seriously considering moving our meeting place again, so be on the lookout for another change.

No guests were present. Current flyers were available for local car events. Ernie announced he is not running for the President position for 2023. He would like to see more members be involved with our club. Please step up and volunteer. He welcomes your help...just call Ernie 805-428-0558.

Jim Ellerbrock, VP: Reminding us of our Holiday Party, Sunday, December 11. Party is booked with Woodland Hills Country Club. Mark your calendars!

Ernie's Car Report: His Plymouth is here tonight. With the head gasket replaced, he has more power. His brother's car got a new radiator. He then found some wires got crossed and broke, that was fixed, and it works again. He also updated us on his Studebaker and Packard, always needing his attention.

Steve Boskovich Plans are made for our Annual BBQ, date is Saturday, August 27! Let's celebrate our Club's 50th (+1) Anniversary! Event and hosts with be at the home of Steve and Sue Boskovich. Special entertainment is planned, THE SUGAR SISTERS! They are a charming vintage-style duo (or trio), bringing classic tunes and dancing. Steve passed around sign-up sheets and will bring to our August meeting as well. If can't attend meeting, please call Steve or Sue to RSVP 818-341-6876.

Chapter 40 San Fernando Valley V-8's
Monthly Meeting for
Tuesday, July 5, 2022
Continued

7:10 7:30 pm Break

Reports of Officers:

Secretary Rex Jaramillo MIA, Joanie Sapper filling in.

Treasurer Joanie reported all good.

Tours-Ernie's Events: 1) **July 29th**, Old Fashioned Day in the Park @ Burton Chace Park, Marina del Rey. Join members Gerard and Pam Buck's vintage yacht club for open tours. Breakfast included and food trucks there for lunch. Call to reserve your classic car's place 310-429-3028. 2) **August 21**, Wings Over Camarillo. See a premier air show of vintage planes. Ernie will have more information at our August meeting. Cruise on over with our club!

Editor's Report: Rob Glucksman is looking for help writing a short review of our upcoming tour to see the Valley Relics Museum, this Saturday, July 9th. Just let him know if you're willing to help!

Membership: Howard Brown has a newly revised edition of our 2022 Roster. Please pick one up or call him for your copy. Ernie has an idea for our cover art for future editions. If you would like to design this, submit idea to Ernie!

Car of the Month: July's COM went to the Firecracker Red and White '57 Fairlane owned by Steve Boskovich.

Name Badge Awarded to Rob Glucksman by Karen Lehman.

Ladies Raffle Beautiful flowerpots awarded to Joanie Sapper and Valerie Ellerbrock by Bobbie Searl.

Program- Ernie introduced club member Kenny Sapper to talk about his recent induction into the West Coast Stock Car Hall of Fame.

50/50: Winner of \$50 went to new member Larry Pearson! Thanks to all that contributed!

Raffles: Steve Lehman had another huge raffle for us! Thanks Steve!

8:30 pm: Meeting adjourned.

Minutes recorded by Joanie Sapper.

Car of the Month

July's COM went to the Firecracker Red and White '57 Fairlane owned by Steve Boskovich. He recently purchased the car from its previous owner in Lake San Marcos. It had been totally restored 9 years ago then parked in his garage. So, Steve has spent his time making it drivable. He loves everything about it!



Speaker

Program- Ernie introduced club member Kenny Sapper to talk about his recent induction into the West Coast Stock Car Hall of Fame. Ernie shared a few memories of attending Saugus Speedway in the '60s and '70s with his own Dad.

Ken began by talking about his earliest days (1950's) going to the Glendale's Grand Central Airport with his father to watch the road races held on the runway. In his teens he drove to Riverside Raceway with a close friend to attend the NASCAR event. He knew he wanted to pursue car racing, just didn't know how he could do it. The most influential person was Frank Deiny, Sr. Frank raced competitively at Saugus and ran a business, Speedway Engineering, selling race car components on Fletcher Drive. Frank was also a past member of the V8 club. They became good friends, a future boss and mentor on and off the track. Frank advised Ken to concentrate on racing in the premier division rather than lower divisions. Thereby learning from "experts". His racing career took off in the years to come. Between 1975-1986 the Speedway Engineering Chassis was the one of the best available cars in the nation. Many NASCAR champion's drove them. Frank offered Ken the company's shop car to race at Saugus Speedway. He won 3 Championships in a row between 1984-1986. He was voted Most Popular Driver at Saugus in 1982.

It was in 1986 that Ken's role at Speedway Engineering changed. Frank passed away from cancer and Ken became President at Speedway Engineering. Ken continued racing and running the business from a different standpoint. His competition became his customers. He also was very interested in growing the business by traveling East to gain a stronger position in the NASCAR market, selling chassis components.

This is a brief background of how Ken's name came up for the West Coast Hall of Fame. Owen Kern called Ken last Fall and asked him for a biography about his involvement in the race car industry. Ken had always considered it "just a hobby." The Hall of Fame board consists of notable people in the industry. And so, Ken was included in the Class of 2022 along with 11 others. The ceremony was held this last June at the Sonoma Raceway. Ken shared many photos from the event as well as pictures from the past and present good friends from our club. Congratulations Kenny!



Tours

valley relics
museum

Valley V8 Tour of the Valley Relics Museum, July 9, 2022
valleyrelicsmuseum.org

We gathered 18 of us to go back in time and remember our Valley as it was in the earlier days. This amazing collection was started by Tommy Gelinias. He has made a home for a unique collection of LA pop culture memorabilia, just what many of us lived through and will never forget thanks to Tommy. Two of his docents, Julia and Bob Ream shared a wealth of information about the two key industries that shaped our valley over 100 years ago: that is the Entertainment and Aerospace worlds that have deep roots right here!

Julia's grandparents, parents, and she herself lived and worked in the movie industry, heavily involved in the great old Westerns that were filmed here. They worked along side such great actors as John Wayne and Tex Ritter. I couldn't keep up with her long list of famous cowboys. Julia said they only have room in this converted hangar for a quarter of the complete collection. There were some beautiful cars on display...a 1964 Pontiac Bonneville Safari Station Wagon with Indian fabric and saddle bags. License plate reads, "Nudie". This car is her favorite! Julia told us the movie industry still borrows from their collection to make movies dated in past times...an old Van de Kamp's sign was used in movie "Once Upon a Time in Hollywood." Also noteworthy, is that Julia is the niece of Glen Strange. Glen was Butch Cavendish, & the Frankenstein Monster.

Then there was Bob's recollections. He retired from Lockheed after 45 years of service. He began there in 1972, working on both the U-2 project (which was the Gary Powers spy plane) and the SR71. They would use a "start cart" under the plane which had a shaft to the SR71 engine. The start cart was powered by two Buick Wildcat V8 motors, built by a racing engine company in Bakersfield. The engineers would stand under the plane and redline the engine. When the engine fired up it shook your insides so bad! These planes were designed in the '60s with a slide ruler...no computers! And they are still the highest flying and fastest plane ever built to this day...faster than a bullet! It's world record between New York to London or Los Angeles to New York is 1 hour 2 minutes still is a record today!

Bob and Julie shared so much information! All the many studios that were built. RKO was on the corner of Roscoe and Balboa. "It's a Wonderful Life" was filmed there. Lockheed started up in 1912 building seaplane...the Curtis planes. The current Van Nuys Airport is the busiest jet business terminal in the world.

If any of these displays are of interest to you, please stop by to see and to hear more! They are open Saturdays and Sundays only, 11 am to 4 pm. Admission is \$15 per person.

We finished our day meeting at Lulu's Restaurant for lunch. It was a very fun tour. Thank you, VP Jim, for planning this for us!

Written by Joanie Sapper

Another point of interest, A long past Valley V8 member , Terry Smith donated his Name badge, a fan & an old Car Plaque

Thanks for doing the writing so I could shoot pics. R/DLE

For more pics, Please go to one of our web sites

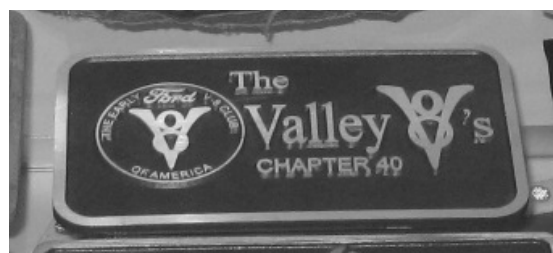

**‘Bad boy’ owners of cool cars feel almost like teens again at donut shop meetup in Chatsworth
Friendships forged over old cars, nostalgia and how times have changed**



Friends and classic car enthusiasts gather at Earl's Doughnuts in Chatsworth every Thursday morning.

(Photo by Andy Holzman, Contributing Photographer)

By DENNIS MCCARTHY |

PUBLISHED: July 14, 2022 at 2:15 p.m. | UPDATED: July 14, 2022 at 2:21 p.m.

If you remember when Earl Scheib was painting cars for \$29.95 — “any car, any color, no ups, no extras” — and gas was 31 cents a gallon, you remember these bad boys from high school.

They had black combs stuck in the back pockets of their tight jeans, a few dabs of Brylcreem in their thick heads of hair, and the coolest cars to ever cruise Van Nuys Boulevard in the 1950s and '60s.

Their combs and Brylcreem vanished with their hair in the '80s, but their cars never left them. Those bad boys from high school are still driving the coolest cars in the San Fernando Valley 65 years later.

“My '57 Ford sold for \$2,300 new, now it's worth \$45,000 fully restored,” says Steve Boskovich, who graduated from Canoga Park High School in 1958, and organized the cruise stop held every Thursday morning at Earl's Donuts in Chatsworth.

It started slow with just three or four cars six years ago, but took off by word of mouth. Now, an average Thursday morning has 15 to 20 cars showing up from 7:30 a.m. to 9 a.m. — bad boys from high school talking carburetors and generators just like they did in auto shop and morning recess.

They're all in their 70s and 80s now, so recess is all day long. They park their Fords and Chevys, Studebakers and Dodges outside Earl's, and walk in for a donut and cup of coffee. None of them as teenagers ever thought they'd be hanging out together with their cars as senior citizens.

“I'll be 83 in two weeks,” Boskovich says to Ernie Bailey, who graduated from Canoga Park High in 1968, 10 years after Boskovich. At 65, he's one of the young guys in the group. He's president of the local Ford club, but he drove a black '55 Dodge to Earl's last Thursday.

“It's cool, really cool, and a big part of my life now, hanging out with these guys for a few hours every week,” Bailey says. “I've come full circle. I almost feel like a teenager again in high school.”

Their cars aren't novelties that they take out of the garage once a week for a spin. Not an expensive toy to show off. They're working cars, out there everyday when the weather's right, says Joe Di Fatta.

“If it is 102 degrees, though, forget it,” he says. Many of the cars in the '50s didn't have air conditioners. They're all their own mechanics. They get their own hands dirty changing the spark plugs and oil. Nothing on their cars is computerized, so they don't have to take a second mortgage out on their house to get a tail light fixed.

Their wives put up with them and know if it's Thursday, come hell or high water, their bad boys will be at Earl's talking cars. Unlike their husbands, they're driving Toyotas and Teslas.

Truth is nobody's blowing their horn and giving the thumbs up sign to a Toyota, but a '57 turquoise and white Chevy? C'mon, that's timeless.

“We get the ‘hi sign’ all the time,” Boskovich says. “People appreciate that these old cars are still on the road and how we're restoring and taking care of them.”

Reminding the rest of us about America back in the '50s and '60s when anything was possible, and we were leading the way for the rest of the world. When Earl Scheib was painting cars for \$29.95 and gas was 31 cents a gallon.

If you own a classic car or just like talking about them, an invitation is open to drop by Earl's any Thursday morning and meet these old bad boys from high school. Earl's is located at 20429 Devonshire St. in Chatsworth.

Dennis McCarthy's column runs on Sunday. He can be reached at dmccarthynews@gmail.com.

The V-8 Ford Summer BBQ

at the home of Steve and Sue Boskovich

Saturday, August 27th. at 3pm.

**This year we will be celebrating the club's
50th Anniversary, with a "Pot Luck" BBQ & Live
Entertainment**

**The Sugar Sisters, A vintage style trio, will be
singing classic tunes from the 40's**

**Please sign up to bring a side dish or appetizer. Help
will also be needed to set up & clean up**

**The "V-8" club will be providing Hamburgers & a
cake for the event**

**Sign up sheets will be available at the July & August
meetings, or you can call Steve at
818-903-6620**

Change of Venue

For the month of 9 AUG 22, We will be trying
Lulu's Restaurant and Sports Bar for our August meeting

