



Drive Lines

Chapter #40

Oct 22

Our 51st Year

Visit Our Website

"ValleyV8s.org"

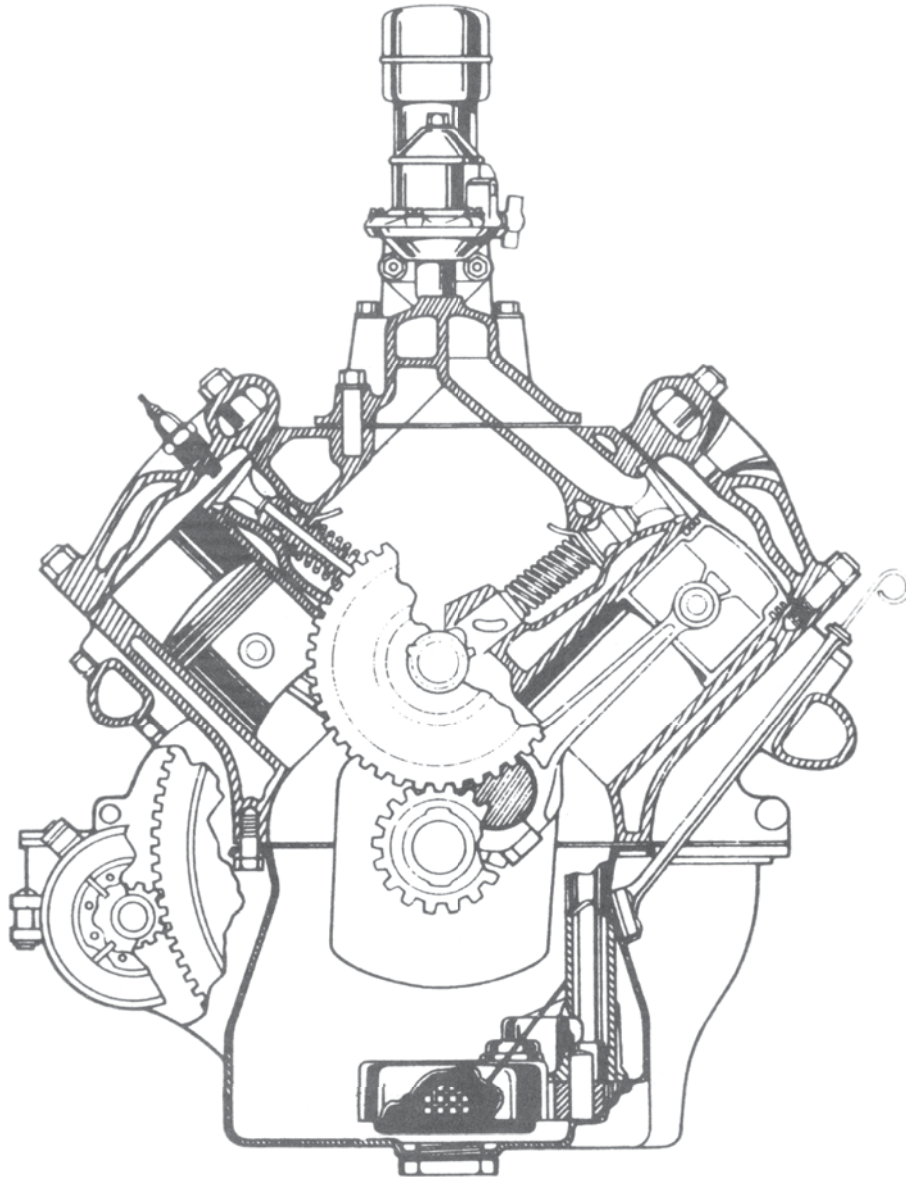

The Valley V8's
9700 Farralone, Chatsworth, Ca. 91311

The Valley V's

2022

President	Ernie Baily	805-433-5540
Past Presidents	Vaskin Hagopian	323-661-2044
Vice President	Jim Ellerbrock	818-437-0412
Secretary	Rex Jaramillo	213-706-3854
Treasurer	Joan Sapper	818-326-9685
Tours	Ernie Baily	805-433-5540
Programs	Larry Caplan	818-363-2849
	Joe DiFatta	818-700-1939
Membership	Howard Brown	818-606-0267
	Joan Sapper	818-326-9685
Drive Lines	Robert Glucksman	818-618-1395
Prize Raffle	Steve Lehman	818-885-6938
50/50	Ken Sapper	818-326-1286
Ladies / Birthdays / Sunshine	Bobby Searl	818-353-6767
Name Badge	Karen Lehman	818-885-6938
Car of the Month	Jim Ellerbrock	818-437-0412
Web Master	Scott Dudrick	818-687-9836

Meeting: 1st Tuesday of the Month, 6:00p

Visit our Web Site: valley V8s.org

Facebook: **Valley V8s**

(<https://www.facebook.com/groups/579123315803014>)

Drive Lines is Published by

The San Fernando V8's Regional Group 40

of the Early Ford V8 Club of America

9700 Farralone, Chatsworth, Ca. 91311

**For more photos of Club Events,
Please check out Web & Facebook sites**

**Lulu's Restaurant
& Sports Bar
16900 Roscoe Blvd,
Van Nuys, CA 91406**

Past Presidents

Jim Rowe	1971
Doug Peterson	1972
Don Durkee	1973-1974
Ed Warnock	1975
John Busk	1976
Chip Werstein	1977
Stan Misraje	1978
Bill Culp	1979
Al Spencer	1980
Larry Caplan	1981
Bob Rose	1982
Don Durkee	1983
Paul Kirk	1984
Kent Lowry	1985
Dave Sanborn	1986
John Kemmerer	1987
Dudley Ochsner	1988
Jerry Jensen	1989-1990
Joe DiFatta	1991
Chuck Shubb	1992-1993
George Richards	1994
Jerry Littner	1995
Dick Smith	1996
Chuck Mair	1997
Dennis Keene	1998
Rose Golt	1999
Don Stout	2000
Steve Boskovich	2001-2002
Joe DiFatta	2003
Wendi Potter	2004
Ken Sapper	2005-2006
Steven Batesole	2007
Harry Baker	2008-2009
Dave Bergman	2010
Randy Watson	2011-2012
Steve Boskovich	2013-2014
Stan Miller	2015
Don Durkee	2015
Vasken Hagopian	2016-2018
Ernie Baily	2019-????

Our Next Meeting
4 Oct 22

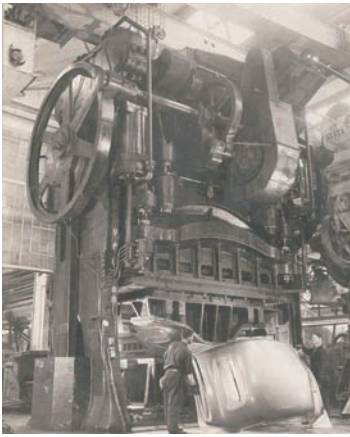

And now for some
"Pressing" News

What are you doing to stay Sane
Write Me something

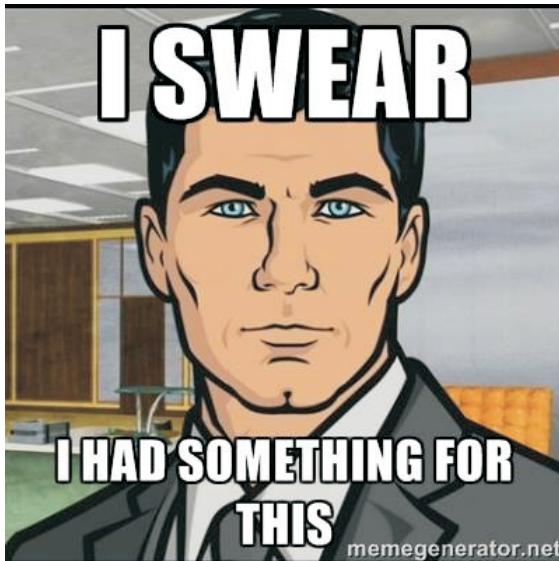

"Your Ad Here"
For only \$5.00 a month,
YOU
can have your
business card ad
right here

For more details,
Please call or Email Rob at
818-882-2002, / madmodelr@aol.com
Please put "Drivelines" in the subject
Please make all payments to
"Valley V8 Club"

HELLO FELLOW MEMBERS

We would like to know more about You, Your Car...
So, What I would like from our members is a picture of you
with your car, with a small story. (1 Paragraph)
That way, We get to learn more about our members, & we
can put a face to a name & car

Please make all submissions to ether
"Drivelines" at madmodelr@aol.com, or
"Drivelines" 9700 Farralone Ave. Chatsworth, Ca. 91311

Thank You

Rob Glucksman, DL Editor

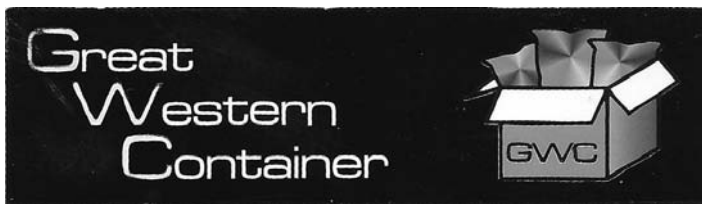

SOLUTIONS IN PACKAGING AND GRAPHIC DESIGN

Steve Boskovich

Office (818) 341-2291
Cell (818) 903-6620
Fax (818) 341-1050

P.O. Box 4074
Chatsworth CA 91313



AL MOONEY
C.F.O.

8744 REMMET AVE.
CANOGA PARK, CA 91304
(818) 998-0199
FAX (818) 341-2073

al@mooneyindustries.com

SPEEDWAY
ENGINEERING



Ken Sapper
President

ken@1speedway.com
Office: 818.362.5865
Cell: 818.326.1286
Fax: 818.362.5608
13040 Bradley Avenue
Sylmar, CA. 91342
www.1speedway.com

MIKE QUIROGA
President/CEO
O: 818.780.8820
F: 818.780.1713

16046 Blythe St.
Van Nuys, CA 91406



ANNIVERSARY 1972-2012

MIKE'S GOT YOU COVERED

www.mikesbuilding.com

From The President

Hello, Everyone,

Well, I'll start with a reminder that our **Oct. meeting is our annual Auction**. So if possible please bring any auto related items in which we can auction off to make money for the club. This is always a fun event, so don't miss it!

Again not a lot to report, However I saw a few of the club members at the Simi Valley "Cops n Cruisers" car show. They had a good turnout, with a nice selection of original type cars. Another thing to think about is the selection of next years officers. A number of us would like to step down and allow other members to participate. It would allow some of our newer members to guide the club and offer fresh ideas. As you all know a lot of our members have held a lot of positions in the past and have always been very active in the club. As members it takes all of us to make a good club and have a great core group.

As far as my old car projects, I have my brothers cars to always run, and I am at a point that I only have one more to go to get to a "Turn Key" state and that is my brothers 1958 President Starlite hardtop which Studebaker produced just over 1000 cars. I have my Plymouth working great now, and my Dodge is working good with some minor wiring issues with the A/C system to contend with. And I'm just about done with the restoration of my 1933 Wards-Hawthorne bicycle too! Now I just have to remember how to ride it!

I'm hoping to put together another board meeting to plan out the rest of the year, I let you know as soon as I can put a date together. I want to remind everybody, if you have a chance to come by and joins us at Earls Donuts every Thursday morning 8am-9:30am and also at Bobs Big Boy in Northridge on Friday nights for a Car Show/Cruise In. And also check out the website "SoCalCarCulture.com" for many Car related events.

Well that is about all I have at this time! I'll see you all at the meeting

Prez Ernie

From the Editor

So, it looks like we all "survived" the Sept heat wave, next comes the elect bill for surviving it. Suffice to say, no one drove their cars without A/C, & rightfully so. We did not have a Car of the Month It looks like Oct will be a better driving month

October Auction

Yep, it's that time, time to bring "SOME" of the stuff your
"Going to Finish some day"
to our upcoming
Oct. Meeting
This is always a big financial boost for the club

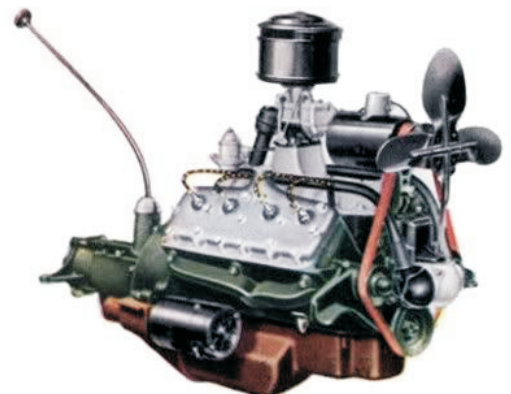

Chapter 40 – San Fernando Valley V-8's Club
Monthly Meeting Minutes for
Tuesday Sept. 6, 2022

7:00 pm Meeting called to order

President Ernie Baily launched the Meeting by leading us in the flag salute.

Opening Comments:

Ernie is back after a bout with heat exhaustion. His projects have been on hold because of the heat. **Vintage Bicycle:** Ernie has a swell old bicycle he's working on. It's a 1933 Montgomery Ward 'Hawthorne' bicycle. The bicycle was originally purchased new by his family. After a time, it was relegated to the barn. So at some point in time, Ernie's Uncle 'restored' the bicycle and Ernie rode it through his early school years. Time marched on and Ernie recently re-inherited the old bicycle and is buying parts online for a major refurbish. He plans to bring it out for a show-and-tell. **Swell V-8 Club barbecue:** Ernie thanked Steve and Sue Boskovich for hosting the barbecue at their home last Saturday. It was a great time had by all, and the Sugar Sisters entertainment was fantastic.

Club Cruise: The cruise to the Camarillo airport car show was outstanding.

Club Auction: Reminder: bring parts and goodies for our annual Club auction in October.

Visitor to our Meeting: Jim Alberts was our visitor. Fred Albrecht brought him. Jim was a member of our Club 8 or 9 years ago. Welcome back!

7:10 pm: Break called

7:25: Meeting Resumed

Reports from Officers:

Secretary: Rex Jaramillo All is OK.

Treasurer: Joan Sapper Reported on beginning and ending balances, all is ok.

Drive Lines Editor: Rob Glucksman -- all OK.

Membership: Howard Brown -- all OK. Howard has Club rosters, available after the meeting.

New Officers needed: Ernie mentioned the opportunities for some of our Club members to consider becoming a club officer.

Upcoming events: Ernie shared information on a few events: 1) Every Friday night: Bob's Big Boy in Northridge, 2) Saturday September 10, Simi Valley: Cops for Cruisers, 3) Sunday November 6, Rancho San Antonio, Chatsworth: Boys Town Car Show, 4) Sunday November 6, Chatsworth: 56th Annual Swap Meet sponsored by San Fernando Valley Model A Club.

NASCAR: Ernie called on Ken Sapper to talk about what's going on with NASCAR: Ken shared that during mishaps on the track, more drivers are getting hurt. He mentioned that the barriers are safer, however the new cars are being built with stronger cages, per NASCAR rules, making the cars very 'stiff'. This is much harder on drivers during accidents. Ken will keep us posted on that and all other topics NASCAR.

Upcoming board meeting: Ernie mentioned his intent to schedule a board meeting. This will include planning for additional Club activities including the Holiday party in December.

September birthdays were announced.

Ladies' Raffle: Handled by Bobbie Searl -- Plants won by Reenie Jaramillo & Sandy Norris

Name Badge: Handled by Karen Lehman: Prize money was won by Monty Goff. **Lucky Monty!** As winner of the Name Badge prize, Ernie asked Monty to say a few words about his car. Monty has a '46 Ford Woody he bought in 1977. It had a flathead engine at that time. Interestingly, it's the same car he brought his son home from the hospital in. So he's had it a long time! During that time span, he's gone thru the car a couple of times. The latest engine is a big-block Chevy, making it more of a rocket than a wagon! Some years ago, Monty was on the 405 freeway heading to a Woodie show in Encinitas. Regrettably, he got broadsided on a left turn. This resulted in \$60K damages to the car. It was an unfortunate incident, however, over time, the woody was repaired and is back on the road to this day. Thanks to Monty for a good summary about his most excellent Ford Woody.

Movie-star Car! Next, Ernie asked Whitney Rydbeck to share about his '46 super deluxe 4 door. In 1979, Whitney was cast in the NBC TV series 'Whitney and the Robot'. A robot was sent to earth to learn more about its people and customs. The robot was discovered by Whitney, a cab driver. Whitney, the robot, and Whitney's neighbor Corky went through many adventures while the robot learned about our earth and its people. For the Show, the '46 had the front bench seat removed so the robot could ride as a passenger. After the series had launched, it was discovered that the '46 purchased by the studios had been stolen and the police thought that Whitney was part of a car theft ring! It was cleared up and the show went on for many more seasons. In the late 1980's the show ended and Whitney bought the '46 for \$2500. And he owns it to this day. And our very own Jerry Case still maintains it for Whitney. Good report, Whitney!

Longest term member: Ernie took a poll among all present to discover who was with our Club the longest. And it was none other than Larry Caplan, congratulations, Larry! Larry joined our Club in 1975.

50/50 drawing: Handled by Ken Sapper, won by Steve Boskovich, congratulations, Steve!

Raffle: Handled by Steve Lehman, who had many nice gifts available for many pleased winners.

8:15 pm: Meeting adjourned.

For the month of 4 Oct 22, Our meeting is still at Lulu's Restaurant & Sports Bar



**Lulu's Restaurant
& Sports Bar
16900 Roscoe Blvd,
Van Nuys, CA 91406**