



# Drive Lines

Chapter #40

Dec 22

*Our 51st Year*

*Visit Our Website*

*"ValleyV8s.org"*

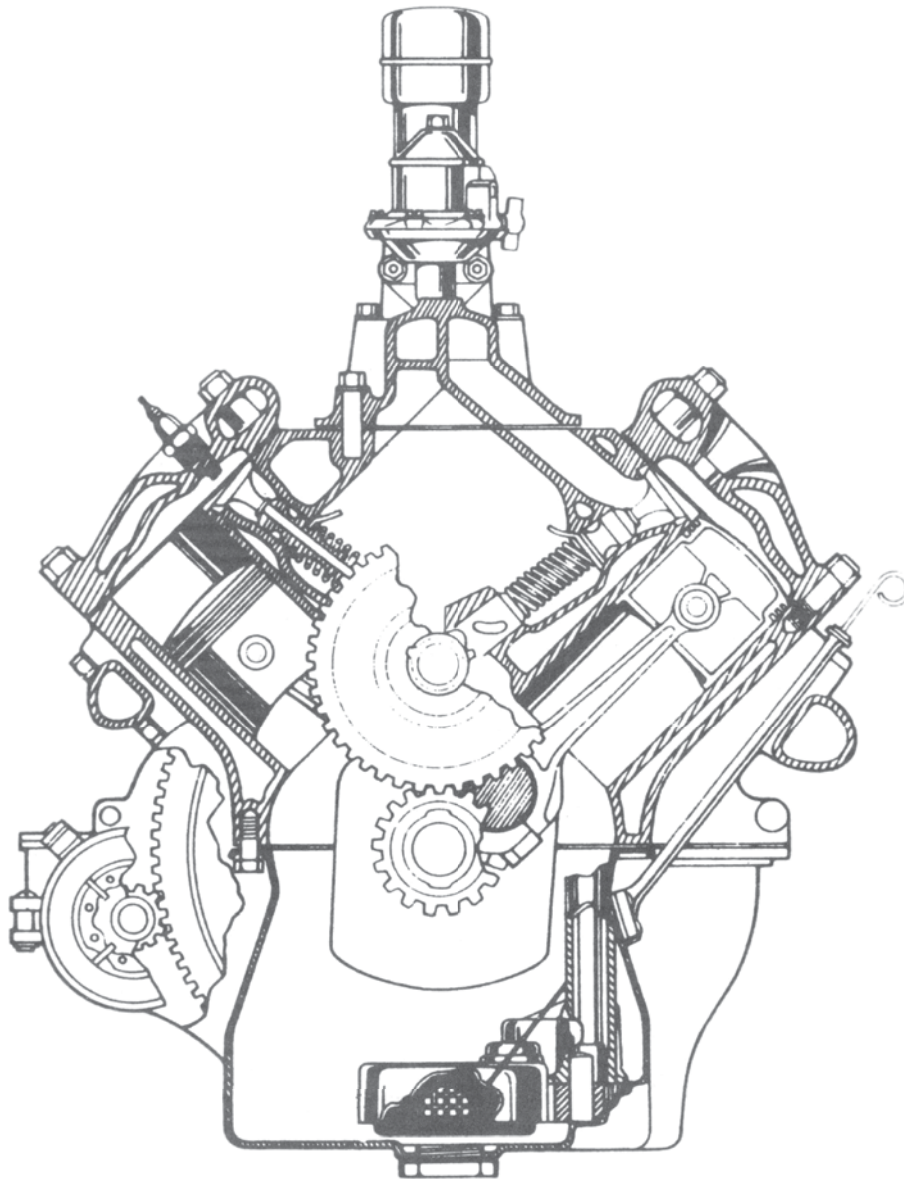

**The Valley V8's**  
**9700 Farralone, Chatsworth, Ca. 91311**

# The Valley V's

2022

President	Ernie Baily	805-433-5540
Past Presidents	Vaskin Hagopian	323-661-2044
Vice President	Jim Ellerbrock	818-437-0412
Secretary	Rex Jaramillo	213-706-3854
Treasurer	Joan Sapper	818-326-9685
Tours	Ernie Baily	805-433-5540
Programs	Larry Caplan	818-363-2849
	Joe DiFatta	818-700-1939
Membership	Howard Brown	818-606-0267
	Joan Sapper	818-326-9685
Drive Lines	Robert Glucksman	818-618-1395
Prize Raffle	Steve Lehman	818-885-6938
50/50	Ken Sapper	818-326-1286
Ladies / Birthdays / Sunshine	Bobby Searl	818-353-6767
Name Badge	Karen Lehman	818-885-6938
Car of the Month	Jim Ellerbrock	818-437-0412
Web Master	Scott Dudrick	818-687-9836

Meeting: 1st Tuesday of the Month, 6:00p

Visit our Web Site: [valley V8s.org](http://valley V8s.org)

Facebook: **Valley V8s**

(<https://www.facebook.com/groups/579123315803014>)

Drive Lines is Published by  
The San Fernando V8's Regional Group 40  
of the Early Ford V8 Club of America  
9700 Farralone, Chatsworth, Ca. 91311

**For more photos of Club Events,  
Please check out Web & Facebook sites**

## *Past Presidents*

Jim Rowe	1971
Doug Peterson	1972
Don Durkee	1973-1974
Ed Warnock	1975
John Busk	1976
Chip Werstein	1977
Stan Misraje	1978
Bill Culp	1979
Al Spencer	1980
Larry Caplan	1981
Bob Rose	1982
Don Durkee	1983
Paul Kirk	1984
Kent Lowry	1985
Dave Sanborn	1986
John Kemmerer	1987
Dudley Ochsner	1988
Jerry Jensen	1989-1990
Joe DiFatta	1991
Chuck Shubb	1992-1993
George Richards	1994
Jerry Littner	1995
Dick Smith	1996
Chuck Mair	1997
Dennis Keene	1998
Rose Golt	1999
Don Stout	2000
Steve Boskovich	2001-2002
Joe DiFatta	2003
Wendi Potter	2004
Ken Sapper	2005-2006
Steven Batesole	2007
Harry Baker	2008-2009
Dave Bergman	2010
Randy Watson	2011-2012
Steve Boskovich	2013-2014
Stan Miller	2015
Don Durkee	2015
Vasken Hagopian	2016-2018
Ernie Baily	2019-????

**Our Next Meeting**  
***Holiday Brunch***

***11 Dec 22***

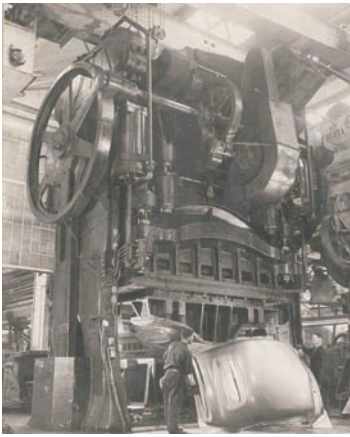

And now for some  
"Pressing" News

**What are you doing to stay Sane**  
**Write Me something**



**"Your Ad Here"**

For only \$5.00 a month,

**YOU**

can have your  
business card ad  
right here

For more details,

Please call or Email Rob at  
818-882-2002, / madmodelr@aol.com  
Please put "Drivelines" in the subject  
Please make all payments to  
"Valley V8 Club"

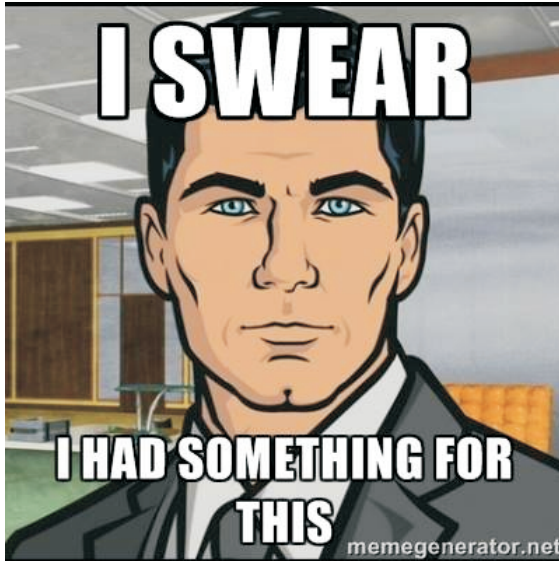

**HELLO FELLOW MEMBERS**

We would like to know more about You, Your Car...  
So, What I would like from our members is a picture of you  
with your car, with a small story. (1 Paragraph)  
That way, We get to learn more about our members, & we  
can put a face to a name & car

Please make all submissions to ether  
"Drivelines" at madmodelr@aol.com, or  
"Drivelines" 9700 Farralone Ave. Chatsworth, Ca. 91311

Thank You

Rob Glucksman, DL Editor



SOLUTIONS IN PACKAGING AND GRAPHIC DESIGN

**Steve Boskovich**

Office (818) 341-2291  
Cell (818) 903-6620  
Fax (818) 341-1050

P.O. Box 4074  
Chatsworth CA 91313



**AL MOONEY**  
C.F.O.

8744 REMMET AVE.  
CANOGA PARK, CA 91304  
(818) 998-0199  
FAX (818) 341-2073

al@mooneyindustries.com

**SPEEDWAY  
ENGINEERING**



**Ken Sapper**  
President

ken@1speedway.com  
Office: 818.362.5865  
Cell: 818.326.1286  
Fax: 818.362.5608  
13040 Bradley Avenue  
Sylmar, CA. 91342  
www.1speedway.com

MIKE QUIROGA  
President/CEO  
O: 818.780.8820  
F: 818.780.1713

16046 Blythe St.  
Van Nuys, CA 91406



ANNIVERSARY 1972-2012

MIKE'S GOT YOU COVERED

www.mikesbuilding.com

# From The President

Hello Everyone,

Well here we are its December were are almost done with another year. We had a great Paradise Cove tour, I wish more of you could have attended. Our next event is our Holiday / Xmas luncheon, so I hope to see you all there.

I know you all have been busy preparing for the holidays. My wife and I are planning a big Thanksgiving! with both side of the family. Our house will be jam packed, I never realized how much Holiday decor I had to set up! I haven't had much time to work on my brothers Packard and Golden Hawk. The only thing was to switch around the cars and put the Packard in the garage and jack it up. We did receive the new oil pump kit for it so now I hope to find some time in the first two weeks of December to work on it. As far as the Golden Hawk goes, I had a problem when I ran out gas when the gauge said half full, so I guess its not fixed yet!

***A reminder to get your 2023 dues in and also to send Jim your request for the Holiday/Xmas ticket too!***

That is all I can think of, So if I don't see you at the Holiday Xmas Luncheon, Have a great Thanksgiving and a Merry Christmas and Happy New Year!

Prez Ernie

---

## Chapter 40 -- San Fernando Valley V-8 Club Monthly Meeting Minutes for Tuesday Nov. 1

### *7:00 pm Meeting called to order*

President Ernie Baily launched the meeting, opened with Pledge of Allegiance.

***Opening Comments:*** Ernie reminded us of the upcoming Veterans's Day, Friday November 11.

**Jim Ellerbrock** shared information about our upcoming Holiday Brunch: It will be held on December 11, same place as last year: **Woodland Hills Country Club**. We'll have the Sugar Sisters there to perform their vintage vocal harmony. Jim is still accepting checks for the Event. Price for members and spouses: \$35 each. Guests: \$40 each. Alcoholic drinks are not available from the restaurant. However you can bring your own drinks if you wish. Just be reminded that there's a 'corking' fee. ***IMPORTANT:*** Remember to bring unwrapped gift toys for kids and gifts for mothers: These gifts will be donated to Haven Hills Center for homeless and at-risk women and children.

### ***Announcements from our President:***

1) Annual Club membership fees are due: For both our local Chapter, San Fernando Valley V-8 Club, and our parent organization, the Early Ford V-8 Club of America. Remember: For insurance reasons, we need to be members of not only our local Chapter club but also members of the Early Ford V-8 Club of America. For convenience, members who would like to renew membership or individuals who would like to join the San Fernando Valley V-8 may use the 2023 Membership Application and Renewal Form. You'll find this in the latest issue of Driveline Newsletter. To renew membership or join our 'parent' organization the 'Early Ford V-8 Club of America', you can go online: <http://www.earlyfordv8.org>

2). Paradise Cove Cruise: This was a most outstanding event: Thank you Scott Doudrick for arranging it: We met at Woodley Park, then cruised as a group down the scenic Las Virgenes highway.

3). November 6: Model A Swap Meet and Car Show 9 am, Rancho San Antonio Boys Town, Chatsworth.

***Program for the Evening Part One:*** Ernie introduced Jerry Case, our first 'impromptu' Speaker for the evening. Jerry and his girlfriend Maxine just returned from a 6,000 mile trip to the Midwest. Jerry grew up in Texas, and Maxine grew up in Indiana. They had a great time visiting family and friend, also neighborhoods where they grew up. One of the highlights was a visit to the Early Ford V-8 Foundation and Museum in Auburn, Indiana. Jerry and Maxine had a 'field day' viewing the vintage Fords and early V-8 displays. They met the fellow in charge of maintaining and moving cars, who provided some very interesting 'insiders' information. One of the most amazing cars on display was the all stainless steel 1936 Ford tudor. A little 'sidenote': The Foundation is separate from the Early Ford V-8 Club of America because of philosophical differences, as explained by Steve Boskovich. Steve also mentioned that our late friend Don Durkee made some Burma Shave signs on display there.

**Chapter 40 -- San Fernando Valley V-8 Club**  
**Monthly Meeting Minutes for**  
**Tuesday Nov. 1**  
**Continued**

**Holidays coming up:** President Ernie announced the upcoming Simi Valley Christmas light tour.

**7:15 pm: Break called**

**7:30: Meeting Resumed**

**Car of the Month:** Three members brought vintage cars, so the Car-of-the-Month money was divided three ways.

**Reports from Officers:**

**Secretary:** Rex Jaramillo All is OK. The Board is still looking for a volunteer to fill the Club Secretary position. We have a most excellent group to work with, a lot of support and it's a fun job taking the Minutes. It's a great opportunity to work with an outstanding Board and get to know new people in the Club.

**Treasurer:** Joan Sapper -- all good.

**Membership:** Howard Brown -- Four past members are renewing their membership, good news, and welcome back!

**Ladies raffle** -- Bobbie Searl beautiful plants won by Joan Sapper & Sandy Norris.

**Name Badge:** Bypassed this month.

**Program for the Evening, Part Two:** President Ernie called on Club members to share what they had going on. **Howard Brown** was first up, describing his new car-toy: A month ago Howard received a phone call from a fellow in Torrance who had a Packard Hawk that he needed to 'get rid of'. The car was located in a driveway under a car cover. It had been painted many years prior, interior re-done, engine rebuilt, then left to sit for nine years. Howard looked it over, offered a price, which wasn't agreed upon, so he told the fellow he'd wait to hear from him. In the mean time, Howard dropped his cell phone, destroyed it, which meant losing the Hawk owner's phone number. Luckily for Howard, the guy called him back to a different phone, and within 30 minutes they had agreed upon a price. So Howard took possession of the Hawk. After getting it home and looking through numerous boxes that came with the car, he discovered that he has most of the parts needed to reassemble the car. After more inspection, Howard feels the car is about  $\frac{3}{4}$  finished. More background: There were only 588 Hawks made with this paint and interior combination, so Howard has a rare one. Fast forward a few days: Howard got the Hawk started, the transmission shifts, however there was a coolant leak: A freeze plug had popped out. And the story continues: Where does this wire go, etc, etc. Good luck Howard, it sounds like you've got a winner. **Second speaker – Ernie Baily:** Ernie took his brother's Studebaker out for a test drive, ran into a fuel problem, had it towed back home. And his brother's '56 Packard appears to have an oil pressure problem. So Ernie bought a 'retro-kit' to hopefully resolve the issue. **Steve Boskovich:** Steve and Sue had an interesting experience on the road: They had a blowout on their 5<sup>th</sup> wheel. Reason: Tire age. Most tire manufacturers recommend replacing aging tires every 6 to 10 years. Reason: The rubber cracks from age, not just on the outside but internally as well. For his '57 Ford, Steve bought new Coker tires, just to play it safe, good move.

**Stan Miller:** Stan hasn't had his '40 Ford out of the garage since 2019. He does start it once a month. The last time, Stan experienced a hard-start condition. He discovered gas coming out of the carburetor. Reason: stuck float. So he tapped the carburetor with a screwdriver handle, and the '40 started just fine. Stan is hoping to get that fine '40 out of the garage one of these days. **Vegas, here we come!** Howard Brown and Jim Ellerbrock will be traveling to Las Vegas to participate in the Mecum Auto Auction as drivers. Keep a lookout for them on TV.

**50/50:** Handled by Vasken Hagopian in Ken Sapper's absence. Ken was at the SEMA show representing his company 'Speedway Engineering'. The 50/50 pot was won by Chris Haynes. Thanks for filling in, Vasken, good job!

**8 pm: Meeting adjourned.**

---

For Pics & story of our Tour to **Paradise Cove**, Please visit our Club site

Visit our Web Site: [valleyV8s.org](http://valleyV8s.org)

Facebook: **Valley V8s**

(<https://www.facebook.com/groups/579123315803014>)



**Valley V8's Board of Directors, Voting Ballot**  
**Please fill out, Yes / Continue, or No, with a Write in**  
**Thank You**

Here are the officer positions:

President: Current President- Ernie Baily / \_\_\_\_\_

Vice President: Current VP- Jim Ellerbrock / \_\_\_\_\_

Secretary: Current Sec- Rex Jamamillo / \_\_\_\_\_

Treasurer: Current Treasurer- Joan Sapper / \_\_\_\_\_

Tours: Current Tours- Kenny Sapper / \_\_\_\_\_

Programs: Current- Larry Caplan & Joe DiFatta / \_\_\_\_\_

Membership: Current- Howard Brown / \_\_\_\_\_

Editor: Current- Rob Glucksman / \_\_\_\_\_

Raffle: Current- Steve Lehman / \_\_\_\_\_

50/50: Current- Kenny Sapper / \_\_\_\_\_

Ladies/Birthdays: Current- Bobby Searl / \_\_\_\_\_

Web Master: Current- Scott Dudrick / \_\_\_\_\_

Name Badge: Current- Karen Lehman / \_\_\_\_\_

Tech Advisor: / \_\_\_\_\_

Write-In / \_\_\_\_\_

***Membership dues notice***

Hello fellow Valley V8 members. It's that time again; time to pay our membership dues for 2023 Please use the form included in this issue of Drivelines; fill it out, enclose a check and mail to the address indicated on the form. Also included is the membership form for the Early Ford V8 Club of America. It IS a rule that we belong to the national club to be permitted to belong to our chapter, so please join if you are not presently a member, or rejoin.



**The Valley V-8's  
Membership Application & Renewal Form  
To renew your membership or  
join our club, please fill out this form  
and follow the instructions at the bottom**

**SAN FERNANDO  
VALLEY V8s  
CHAPTER 40**  
www.ValleyV8s.org  
Https://www.facebook.com/groups/  
579123315803014

**Name:** \_\_\_\_\_ **Birthday Month:** \_\_\_\_\_ **Day:** \_\_\_\_\_

**Spouse:** \_\_\_\_\_ **Birthday Month:** \_\_\_\_\_ **Day:** \_\_\_\_\_

**Address:** \_\_\_\_\_ **City:** \_\_\_\_\_ **State & Zip** \_\_\_\_\_

**Phones - Home** \_\_\_\_\_ **Cell** \_\_\_\_\_ **Work** \_\_\_\_\_

**Email:** \_\_\_\_\_

**Occupation:** \_\_\_\_\_

**Year Joined:** \_\_\_\_\_

**Early Ford V-8 Vehicle(s) Owned - if same as prior year write "NO CHANGE"**

<u>Year</u>	<u>Make</u>	<u>Model</u>	<u>Body</u>	<u>Style</u>
-------------	-------------	--------------	-------------	--------------

**For Regional Membership: Send a \$35.00 check - payable to: Valley V-8's**

**Mail check to: Valley V8's CIO Howard Brown, 20036 Tuba St. Chatsworth, Ca.  
91311**

**If you have any questions please call 818-606-0267 Email: brngarage@gmail.com**

**NOTE: For us to meet insurance requirements, a Regional Group Member MUST also be a member of the Early Ford V-8 Club of America. Minimum membership is \$35.00 per year. Please contact me for mailing information or <http://www.earlyfordv8.org>**



# You're invited to Join

Mail In Membership Application Form



## Early Ford V-8 Club of America



An International Organization

### MEMBERSHIP APPLICATION

New Membership      *Check Box as Required*       Renewal Membership

MEMBER NAME \_\_\_\_\_ Regional Group: \_\_\_\_\_

JOINT NAME \_\_\_\_\_

ADDRESS \_\_\_\_\_

CITY \_\_\_\_\_ STATE \_\_\_\_\_ ZIP \_\_\_\_\_

TELEPHONE \_\_\_\_\_ COUNTRY \_\_\_\_\_

#### CAR(S) OWNED

<u>YEAR</u>	<u>MAKE</u>	<u>TRIM</u>	<u>ENGINE</u>	<u>BODY STYLE</u>
Sample: 1940	FORD	DELUXE	V-8	TUDOR SEDAN
_____	_____	_____	_____	_____
_____	_____	_____	_____	_____

PLEASE SEND FORM & PAYMENT TO:  
**THE EARLY FORD V-8 CLUB OF AMERICA**  
 c/o Cornerstone Registration, Ltd.  
 P.O. Box 1715      Toll Free (866) 427-7583 (in USA)  
 Maple Grove, MN 55311      (763) 420-7829 / FAX (763) 420-7849  
 Email: registration@cornerstonereg.com

**Credit Card: VISA MASTERCARD (circle one)**  
 CARD # \_\_\_\_\_ - \_\_\_\_\_ - \_\_\_\_\_  
 EXPIRATION DATE: \_\_\_\_\_  
 SIGNATURE: \_\_\_\_\_

#### ALL FUNDS ARE US \$

##### United States

Annual-Surface Mail  
 Regular Membership \$35, Joint Membership \$38  
 Three Year-Surface Mail  
 Regular Membership \$100, Joint Membership \$109

##### Canada

Annual-Surface Mail  
 Regular Membership \$55, Joint Membership \$58  
 Three Year-Surface Mail  
 Regular Membership \$150, Joint Membership \$160

##### Mexico, South America, Europe & Pacific Rim

Annual-Surface Mail  
 Regular Membership \$70, Joint Membership \$75  
 Three Year-Surface Mail  
 Regular Membership \$200, Joint Membership \$210

**NEW: Digital Format for Both Magazine and Annual Roster**  
 (digital version emailed to you, no magazine or roster mailed)  
 Annual Digital Membership  
 Regular Digital Membership \$30  
 Your Email Address: \_\_\_\_\_

Membership without V8 TIMES Delivery	One-Year	Three-Year
<input type="checkbox"/> U.S. & All Foreign Countries:	Regular \$15 Joint \$18	Regular \$45 Joint \$54 <i>WITH</i> Membership Roster only.
<input type="checkbox"/> U.S. & All Foreign Countries:	Regular \$ 5 Joint \$ 5	Regular \$15 Joint \$15 <i>WITHOUT</i> Membership Roster.

Thank you for Joining or Renewing your membership in The Early Ford V-8 Club of America

How did you find out about us? \_\_\_\_\_

## Early Ford V-8 Club of America

An International Organization

Established in 1963 We are dedicated to the restoration and preservation of all Ford Motor Company vehicles, 1932 through 1953.



# SAN FERNANDO VALLEY V8's



## Early Ford V-8 Holiday Brunch



We provide safety, shelter and support to domestic violence survivors.

Get help through our 24/7 Crisis Line at 818-887-6589

**Date:** Sunday, December 11, 2022

**Time:** 11:00 to 1:30

**Location:** Woodland Hills Country Club  
21150 Dumetz Road  
Woodland Hills, Ca. 91364

(note: Entrance is just west of Escobedo Street)

**Cost:** \$35 for members, \$35 for spouses of members, \$40 for Guests

**Make checks payable to:** Early Ford V-8 Club

**Mail to:** Jim Ellerbrock  
10937 Babbitt Ave,  
Granada Hills, Ca. 91344

**PLEASE, help us support  
Haven Hills,  
Bring a Gift for Moms & Toys for  
Kids to the Holiday Party  
Thank You for your Generous  
Contributions**



I will also be available at our next meeting,  
November 1, 2022, to take checks.  
*Entertainment: The "Sugar Sisters" from the  
Summer BBQ will be returning*

**Names of Party Goers:** \_\_\_\_\_

**Home Phone:** \_\_\_\_\_

**Amount Enclosed:** \_\_\_\_\_





Date: Sunday, December 11, 2022

Time: 11:00 to 1:30

Location: Woodland Hills Country Club  
21150 Dumetz Road  
Woodland Hills, Ca. 91364

(note: Entrance is just west of Escobedo Street)

Cost: \$35 for members, \$35 for spouses of members, \$40 for Guests

Make checks payable to: Early Ford V-8 Club

Mail to: Jim Ellerbrock

# Holiday Brunch Map