



Drive Lines

Chapter #40

Nov 2020

Our 49th Year

Visit Our Website

" ValleyV8s.org "

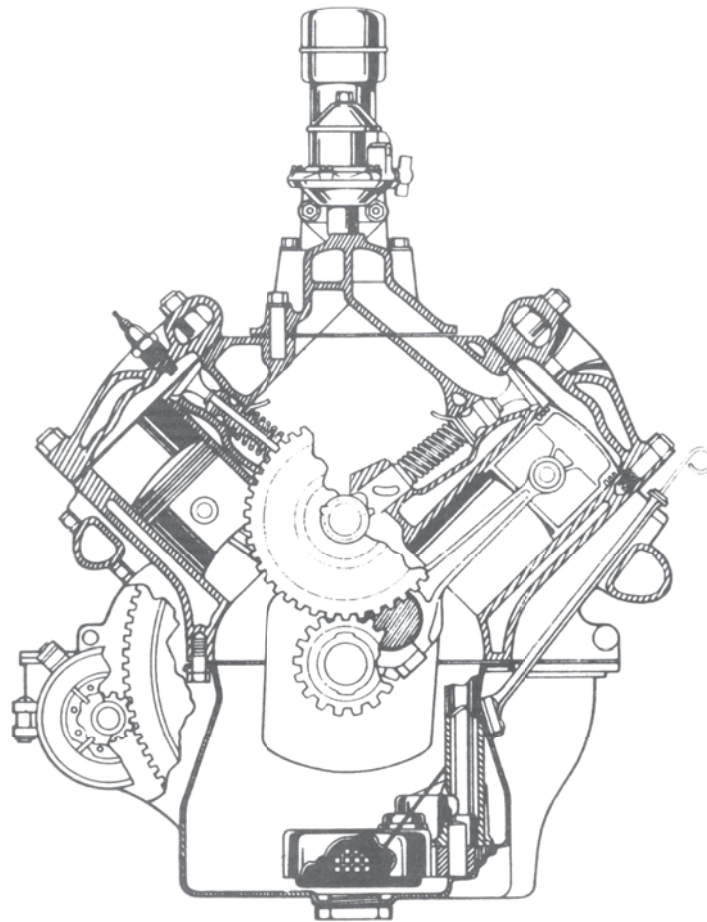

The Valley V8's
9700 Farralone, Chatsworth, Ca. 91311

The Valley V8's

2020

President	Ernie Baily	805-433-5540
Past Presidents	Vaskin Hagopian	323-661-2044
Vice President	Jim Ellerbrock	818-437-0412
Secretary	Rex Jaramillo	213-706-3854
Treasurer	Joan Sapper	818-249-5686
Tours	Kenney Sapper	818-249-5686
	RichCarter	708-567-2393
Programs	Larry Caplan	818-363-2849
	Joe DiFatta	818-700-1939
Membership	Howard Brown	818-606-0267
	Joan Sapper	818-249-5686
Drive Lines	Robert Glucksman	818-618-1395
Prize Raffle	Steve Lehman	818-885-6938
50/50	Ken Sapper	818-380-5686
Ladies / Birthdays / Sunshine	Bobby Searl	818-353-6767
Name Badge	Karen Lehman	818-885-6938
Car of the Month	Jim Ellerbrock	818-437-0412
Web Master	Scott Dudrick	818-687-9836
Tech. Advisor	John Wolf	818-789-6201

Meeting: 1st Tuesday of the Month, 7:00p
 No host Dinner, Starting at 6:00p
 Rosie's BBQ & Grill, 8930 Corbin Ave.
 Northridge, Ca. 91324

Visit our Web Site: valleyv8s.org
 Facebook: **Valleyv8s**
 (<https://www.facebook.com/groups/579123315803014>)

Drive Lines is Published by
 The San Fernando V8's Regional Group 40
 of the Early Ford V8 Club of America
 9700 Farralone, Chatsworth, Ca. 91311

Past Presidents

Jim Rowe	1971
Doug Peterson	1972
Don Durkee	1973-1974
Ed Warnock	1975
John Busk	1976
Chip Werstein	1977
Stan Misraje	1978
Bill Culp	1979
Al Spencer	1980
Larry Caplan	1981
Bob Rose	1982
Don Durkee	1983
Paul Kirk	1984
Kent Lowry	1985
Dave Sanborn	1986
John Kemmerer	1987
Dudley Ochsner	1988
Jerry Jensen	1989-1990
Joe DiFatta	1991
Chuck Shubb	1992-1993
George Richards	1994
Jerry Littner	1995
Dick Smith	1996
Chuck Mair	1997
Dennis Keene	1998
Rose Golt	1999
Don Stout	2000
Steve Boskovich	2001-2002
Joe DiFatta	2003
Wendi Potter	2004
Ken Sapper	2005-2006
Steven Batesole	2007
Harry Baker	2008-2009
Dave Bergman	2010
Randy Watson	2011-2012
Steve Boskovich	2013-2014
Stan Miller	2015
Don Durkee	2015
Vasken Hagopian	2016-2018
Ernie Baily	2019-????

Our Next Meeting
UNKNOWN 2020

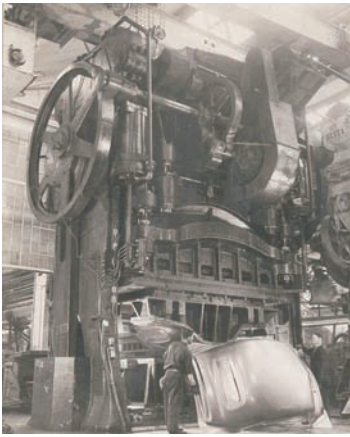

And now for some
"Pressing" News

What are you doing to stay Sane
Write Me something



"Your Ad Here"
For only \$5.00 a month,
YOU
can have your
business card ad
right here

For more details,
Please call or Email Rob at
818-882-2002, / madmodelr@aol.com
Please put "Drivelines" in the subject
Please make all payments to
"Valley V8 Club"



CHAPTER 40 -- SAN FERNANDO VALLEY V-8'S CLUB
MONTHLY MEETING MINUTES FOR
No Meeting, No Minutes.....

HELLO FELLOW MEMBERS

We would like to know more about You, Your Car...
So, What I would like from our members is a picture of you
with your car, with a small story. (1 Paragraph)
That way, We get to learn more about our members, & we
can put a face to a name & car

Please make all submissions to ether
"Drivelines" at madmodelr@aol.com, or
"Drivelines" 9700 Farralone Ave. Chatsworth, Ca. 91311

Thank You

Rob Glucksman, DL Editor



SOLUTIONS IN PACKAGING AND GRAPHIC DESIGN

Steve Boskovich

Office (818) 341-2291
Cell (818) 903-6620
Fax (818) 341-1050

P.O. Box 4074
Chatsworth CA 91313



8744 REMMET AVE.
CANOGA PARK, CA 91304
(818) 998-0199
FAX (818) 341-2073

AL MOONEY
C.F.O.

al@mooneyindustries.com

SPEEDWAY
ENGINEERING



Ken Sapper
President

ken@1speedway.com
Office: 818.362.5865
Cell: 818.326.1286
Fax: 818.362.5608
13040 Bradley Avenue
Sylmar, CA. 91342
www.1speedway.com

MIKE QUIROGA
President/CEO
O: 818.780.8820
F: 818.780.1713

16046 Blythe St.
Van Nuys, CA 91406



ANNIVERSARY 1972-2012

MIKE'S GOT YOU COVERED

www.mikesbuilding.com

Cars 'n Coronavirus

I must be honest, I'm not thrilled to be writing this. Times could be better; we could be better. But, life does go on, and if we don't make the best of what we have, we miss out.

When everything first "went south" back around March it seemed like there was absolutely nothing to do. We couldn't safely gather with our friends (car guys or otherwise), we couldn't eat at restaurants, we couldn't really do much. As time went by and we learned more about the situation, we found that if we took certain precautions we could gather in limited groups, keep our distance from each other and actually have some good times. I have been very glad to see most of the car guys I know "adjust" to the situation so we could get back together.

At first (back in March and April) everyone was so nervous and scared that almost nothing was happening. Now, I think we have made some "adjustments" and found that if we are smart and careful, life can go on. I am really happy to see a lot of my "car guy" friends back at Earl's, Bob's, the Sunday gathering at Shirley Ave and Plummer (behind the bank) and some other places.

Let's continue to be careful and hopefully the virus situation will improve and we can have more and bigger events. Please take a look at the pictures to see what has been going on lately.

Attached are some pictures from various local venues.

Thanks Howard



From The President

Hello Every one,

I have had some thoughts about meeting at Rosies next week for a meeting on there patio is probably not a good Idea. I keep hearing more and more news of more Covid-19 cases showing up. I am thinking the Zoom meeting is still the best thing and safe thing to do. Hopefully next year will be better to plan a real meeting.

As far as my old car projects, I'm still working on my brothers 56 Studebaker Golden Hawk which I have finally driven to Bobs Friday night cruise night. I just purchased my brothers 1958 Studebaker President Starlight Hardtop (only 1040 made), I now have my own 3 car fleet (55 Dodge, 48 Plymouth and now a 58 Studebaker President). I have got the Carb out for rebuild and bought a new Battery. If all goes well I hope to get it running in about a week or so. Then work on the brakes and get the gas tank cleaned. I just sent off the fuel tank sending unit for repair for my brothers 1956 Packard 400 and we have located a replacement fuel tank for it as well. Soon will have all the cars in the Baily Brothers old Car Fleet running and driving!

On a tech note I found a great article on Swaging wheel studs. Here is the web page:
<http://www.fordgarage.com/page/swaging.htm>

I am hoping to put together a driving tour towards the middle of the month. There was a series of Sunday Drives in the current Auto Club Westways magazine, I'm considering doing the Malibu drive, we will send a email out regarding the date. So I hope all is well with everyone and maybe soon we can have a real meeting.

Prez Ernie

FROM THE EDITORS DESK

SO.....

As I compose this Nov. Newsletter, I noticed that the coming 2021, this club will be 50 years old

WOW. That is a lot of history. I... Would like to know more about that history.

What I would like to see, & what I'm asking is for YOU folks, Write a short story, nothing much, just a memory. Good, Bad, Anything, How did you join? Who do you remember? Really, anything, Something...

Lets share, what does this club mean.... Also, Send Me a pic of yourself with / without your ride...

Now, depending on the way we come out of this "Cluster *@#\$\$", the posponed Xmas brunch, will most likely happen in 2021, & I'm thinking that it be a celebration of the 50...

Happy Tday...

Be Well, Ride Well

Rob / DLE

