



Drive Lines

Chapter #40

Dec 2020

Our 49th Year

Visit Our Website

" ValleyV8s.org "

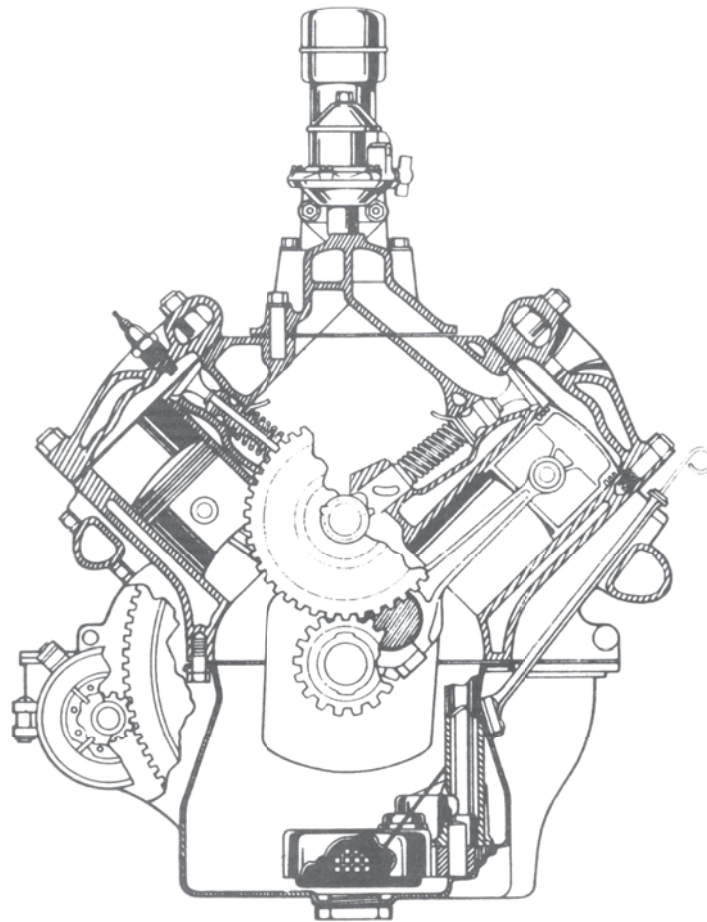

The Valley V8's
9700 Farralone, Chatsworth, Ca. 91311

The Valley V's

2020

President	Ernie Baily	805-433-5540
Past Presidents	Vaskin Hagopian	323-661-2044
Vice President	Jim Ellerbrock	818-437-0412
Secretary	Rex Jaramillo	213-706-3854
Treasurer	Joan Sapper	818-249-5686
Tours	Kenney Sapper	818-249-5686
	RichCarter	708-567-2393
Programs	Larry Caplan	818-363-2849
	Joe DiFatta	818-700-1939
Membership	Howard Brown	818-606-0267
	Joan Sapper	818-249-5686
Drive Lines	Robert Glucksman	818-618-1395
Prize Raffle	Steve Lehman	818-885-6938
50/50	Ken Sapper	818-380-5686
Ladies / Birthdays / Sunshine	Bobby Searl	818-353-6767
Name Badge	Karen Lehman	818-885-6938
Car of the Month	Jim Ellerbrock	818-437-0412
Web Master	Scott Dudrick	818-687-9836
Tech. Advisor	John Wolf	818-789-6201

Meeting: 1st Tuesday of the Month, 7:00p
 No host Dinner, Starting at 6:00p
 Rosie's BBQ & Grill, 8930 Corbin Ave.
 Northridge, Ca. 91324

Visit our Web Site: valleyv8s.org

Facebook: **Valleyv8s**

(<https://www.facebook.com/groups/579123315803014>)

Drive Lines is Published by
 The San Fernando V8's Regional Group 40
 of the Early Ford V8 Club of America
 9700 Farralone, Chatsworth, Ca. 91311

Past Presidents

Jim Rowe	1971
Doug Peterson	1972
Don Durkee	1973-1974
Ed Warnock	1975
John Busk	1976
Chip Werstein	1977
Stan Misraje	1978
Bill Culp	1979
Al Spencer	1980
Larry Caplan	1981
Bob Rose	1982
Don Durkee	1983
Paul Kirk	1984
Kent Lowry	1985
Dave Sanborn	1986
John Kemmerer	1987
Dudley Ochsner	1988
Jerry Jensen	1989-1990
Joe DiFatta	1991
Chuck Shubb	1992-1993
George Richards	1994
Jerry Littner	1995
Dick Smith	1996
Chuck Mair	1997
Dennis Keene	1998
Rose Golt	1999
Don Stout	2000
Steve Boskovich	2001-2002
Joe DiFatta	2003
Wendi Potter	2004
Ken Sapper	2005-2006
Steven Batesole	2007
Harry Baker	2008-2009
Dave Bergman	2010
Randy Watson	2011-2012
Steve Boskovich	2013-2014
Stan Miller	2015
Don Durkee	2015
Vasken Hagopian	2016-2018
Ernie Baily	2019-????

Our Next Meeting
UNKNOWN 2021

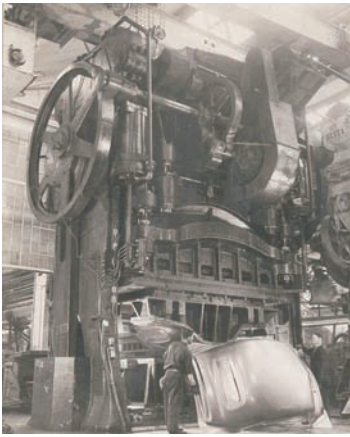

And now for some
"Pressing" News

What are you doing to stay Sane
Write Me something



"Your Ad Here"
For only \$5.00 a month,
YOU
can have your
business card ad
right here

For more details,
Please call or Email Rob at
818-882-2002, / madmodelr@aol.com
Please put "Drivelines" in the subject
Please make all payments to
"Valley V8 Club"



CHAPTER 40 -- SAN FERNANDO VALLEY V-8'S CLUB
MONTHLY MEETING MINUTES FOR
No Meeting, No Minutes.....

HELLO FELLOW MEMBERS

We would like to know more about You, Your Car...
So, What I would like from our members is a picture of you
with your car, with a small story. (1 Paragraph)
That way, We get to learn more about our members, & we
can put a face to a name & car

Please make all submissions to ether
"Drivelines" at madmodelr@aol.com, or
"Drivelines" 9700 Farralone Ave. Chatsworth, Ca. 91311

Thank You

Rob Glucksman, DL Editor

Great Western Container

SOLUTIONS IN PACKAGING AND GRAPHIC DESIGN

Steve Boskovich

Office (818) 341-2291
Cell (818) 903-6620
Fax (818) 341-1050

P.O. Box 4074
Chatsworth CA 91313



8744 REMMET AVE.
CANOGA PARK, CA 91304
(818) 998-0199
FAX (818) 341-2073

AL MOONEY
C.F.O.

al@mooneyindustries.com

**SPEEDWAY
ENGINEERING**



Ken Sapper
President

ken@1speedway.com
Office: 818.362.5865
Cell: 818.326.1286
Fax: 818.362.5608
13040 Bradley Avenue
Sylmar, CA. 91342
www.1speedway.com

MIKE QUIROGA
President/CEO
O: 818.780.8820
F: 818.780.1713

16046 Blythe St.
Van Nuys, CA 91406



ANNIVERSARY 1972-2012

MIKE'S GOT YOU COVERED

www.mikesbuilding.com

Just Crusin....

Fords Crusin' from the Mountains to the Sea

On Friday November 20th, a bunch of our club members gathered with their Fords (and a few other brands) to enjoy each other's company and cars. We started out at the Denny's restaurant in Woodland Hills (at Topanga Canyon Blvd and the Ventura freeway).

It didn't start well. By the time the last car (and there were ONLY 6) left Denny's, the others were nowhere in sight! Somehow, there was a major lack of understanding regarding how we would stay together for the cruise. We (I was riding with Jim and Val Ellerbrock in their really cool '65 Mercury station wagon) knew the general directions, so we went west on Ventura Blvd., stumbled around a little and went south on Fallbrook (under the impression it would take us to Mulholland Drive; NOPE). We then went west on a street parallel to the Ventura freeway until we got to Valley Circle, which we took south and found Mulholland Highway, which took us to the first meeting point (King Gillette Ranch at the intersection of Mulholland Highway and Las Virgenes).

We met everyone else there (finally) and had a nice stop to reconvene and talk (and let our tired, old 'horses' rest). From there we headed south on Las Virgenes (which becomes Malibu Canyon road) to Pacific Coast Highway and across to Malibu Bluffs Park, a very nice park with benches. Somehow, between King Gillette Ranch and Malibu Bluffs Park, we lost half of the group (and didn't see them again for the duration of the cruise.) The remaining group had a very nice lunch at the park and enjoyed the ocean breezes. After lunch we continued north up PCH to Yerba Buena Rd. and turned inland. This was a very nice, but VERY narrow winding road for that went on for quite a long time. We all drove at a leisurely pace and enjoyed the scenery and stopped for a break at Sandstone Peak Trailhead.

After the break, we continued until we reached a choice of the Ventura freeway or California 23 and from there we split up and each returned home.

All together, a really nice cruise set up by Prez Ernie. Great job Ernie! Let's do more of these. Attending (at least in the beginning) were Ernie with his faithful '55 Dodge, Oliver Calibet and Sandrine Cutright with their cool '53 Ford wagon, Harvey and Roberta Jacobs in their beautiful '51 Ford convertible, our Drivelines editor Rob Glucksman driving his '55 Ford Mainline 2 door, a guest from another club, Ron Morgan with his '50 Rocket Oldsmobile and Jim and Val Ellerbrock with their '65 Mercury station wagon, who kindly allowed me to ride with them. I hope those who were unable to participate, enjoy the pictures.

Howard Brown



From The President

Hello Everyone,

Hope all is well with every one. Well to start with it looks like the issue of us having a real meeting is still out of the question for a while, so I guess we'll do the Zoom meeting on our normal meet date.

The first thing I want to say is that we had a nice "Mountains & Sea" Tour . The weather was great! We had 6 vintage cars join us in all and had a nice drive. I had some car problems with my car, but with all the help of everyone we were able to overcome and continue with the tour. I made some "On the Fly" changes in the beginning with the hope it would be a more scenic drive and it did, but it caused some confusion. However we had a great time with a lot of conversation. I'm sending Rob some of the photos I took to put in the Drivelines.

I'm starting to put together a little Xmas tour of some Xmas light locations, we can discuss at the Zoom meeting.

I'm also putting together a ballot for our V8 Club officers for 2021. Please review and submit your vote/views via email or mail-in.

As far as my Car exploits go, I have just about got my brothers 56 Studebaker Golden Hawk to be considered driveable again. I had a problem with the neutral safety switch not allowing the car to start when hot.(its located on the steering column near the exhaust manifold) which would only worked when you wiggled the gear selector. I put a little jumper wire in temporary until I get a replacement. I took it for a test drive and when I got back to check it, the radiator was leaking big time spraying rusty water all over the motor. So now the radiator is at the shop getting repairs. As far as my newly purchased 58 Studebaker President Starlight Hardtop goes, I have it running, and it moves forward and back fine, but No Brakes! The story continues! Now I have the issues with my Dodge. I had to replace the fuel pump, along with trying find the electrical problems with the electronic ignition has been fun. I think I have found the problem, I also discovered the the fuel was boiling just before it went into the carb because the upper water hose is resting on the fuel line just before going into the carb. Ah! The joys of playing with old cars.

Well as I sign off for this year I wish you all Happy Hoildays! I hope next will be much better!

Prez Ernie

Happy Holidays Everyone
Hope everybody had a great Thanksgiving
So,,, Here we are, STILL Separated from our Loved ones
Well, I'm sorry to say that the annual Holiday Brunch has been postponed
The new tentative new date is May 23, 2021
Sorry....

Valley V8's Board of Directors, Voting Ballot
Please fill out, Yes / Continue, or No, with a Write in
Thank You

Here are the officer positions:

- President: Current President- Ernie Baily / _____
- Vice President: Current VP- Jim Ellerbrock / _____
- Secretary: Current Sec- Rex Jamamillo / _____
- Treasurer: Current Treasurer- Joan Sapper / _____
- Tours: Current Tours- Kenny Sapper / _____
- Programs: Current- Larry Caplan & Joe DiFatta / _____
- Membership: Current- Howard Brown / _____
- Editor: Current- Rob Glucksman / _____
- Raffle: Current- Steve Lehman / _____
- 50/50: Current- Kenny Sapper / _____
- Ladies/Birthdays: Current- Bobby Searl / _____
- Web Master: Current- Scott Dudrick / _____
- Name Badge: Current- Karen Lehman / _____
- Tech Advisor: Current- John Wolf / _____
- Write-In / _____

Membership dues notice

Hello fellow Valley V8 members. It's that time again; time to pay our membership dues for 2021 (at least it signifies that 2020 is OVER). Please use the form included in this issue of Drivelines; fill it out, enclose a check and mail to the address indicated on the form. Also included is the membership form for the Early Ford V8 Club of America. It IS a rule that we belong to the national club to be permitted to belong to our chapter, so please join if you are not presently a member, or rejoin.

**The Valley V-8's
2021 Membership Application & Renewal Form**

In order to continue to receive the Drivelines and remain in the roster

Or to join our club

Please renew your membership by February 15, 2021

Name: _____ **Birthday Month:** _____ **Day:** _____

Spouse: _____ **Birthday Month:** _____ **Day:** _____

Address: _____ **City:** _____ **State & Zip** _____

Phones - Home _____ **Cell** _____ **Work** _____

Email: _____

Occupation: _____

Year Joined: _____

Early Ford V-8 Vehicle(s) Owned - if same as prior year write "NO CHANGE"

<u>Year</u>	<u>Make</u>	<u>Model</u>	<u>Body</u>	<u>Style</u>
-------------	-------------	--------------	-------------	--------------

For Regional Membership: Send a \$35.00 check - payable to: Valley V-8's

**Mail check to: Valley V8's CIO Howard Brown, 20036 Tuba St. Chatsworth, Ca.
91311**

If you have any questions please call 818-606-0267 Email: brngarage@gmail.com

NOTE: For us to meet insurance requirements, a Regional Group Member MUST also be a member of the Early Ford V-8 Club of America. Minimum membership is \$35.00 per year. Please contact me for mailing information or <http://www.earlyfordv8.org>